



# 2025 WILDFIRE MITIGATION PLAN UPDATE

San Diego Gas & Electric  
April 2, 2024



# Table of Contents

- 1 Updates to Risk Models .....2**
  - 1.1 Significant Updates ..... 2
    - 1.1.1 Top Risk-Contributing Circuit, Segments, or Spans..... 5
    - 1.1.2 Qualitative Updates ..... 7
  - 1.2 Non-Significant Updates ..... 14
- 2 Changes to Approved Targets, Objectives, and Expenditures .....15**
  - 2.1 Objectives..... 15
    - 2.1.1 Grid Design, Operations, and Maintenance..... 16
      - 2.1.1.1 Wireless Fault Indicators (WMP.449) ..... 16
      - 2.1.1.2 Expulsion Fuse Replacement (WMP.459) ..... 16
      - 2.1.1.3 Transmission System Hardening (WMP.543; WMP.544; WMP.545) ..... 17
      - 2.1.1.4 Maintenance, repair, and replacement of connectors, including hotline clamps (WMP.464) ..... 17
      - 2.1.1.5 Distribution Communications Reliability Improvements (LTE) (WMP.549)..... 17
    - 2.1.2 Vegetation Management and Inspection ..... 17
    - 2.1.3 Situational Awareness and Forecasting ..... 17
      - 2.1.3.1 Weather Stations and Normalized Difference Vegetation Index Cameras (WMP.447) . 17
    - 2.1.4 Emergency Preparedness..... 18
      - 2.1.4.1 Public Outreach and Education Awareness Program (WMP.527) ..... 18
      - 2.1.4.2 Personnel Qualifications (WMP.1335) ..... 18
      - 2.1.4.3 Personnel Qualifications (WMP.1335) ..... 18
      - 2.1.4.4 Personnel Qualifications (WMP.1335) ..... 18
    - 2.1.5 Community Outreach and Engagement ..... 18
    - 2.1.6 Public Safety Power Shutoff..... 18
      - 2.1.6.1 Risk Assessment Improvement Plan (WMP.1339)..... 18
  - 2.2 Targets and Expenditures ..... 19
    - 2.2.1 Grid Design, Operations, and Maintenance..... 23
      - 2.2.1.1 Wireless Fault Indicators (WMP.449) ..... 23
      - 2.2.1.2 Covered Conductor (WMP.455)..... 23
      - 2.2.1.3 Expulsion Fuse Replacement (WMP.459) ..... 23
      - 2.2.1.4 Microgrids (WMP.462)..... 24
      - 2.2.1.5 Advanced Protection (WMP.463) ..... 24
      - 2.2.1.6 Hotline Clamp Replacement Program (WMP.464) ..... 24
      - 2.2.1.7 Generator Grant Program (WMP.466) ..... 25
      - 2.2.1.8 Generator Assistance Program (WMP.467)..... 25
      - 2.2.1.9 Standby Power Programs (WMP.468) ..... 26
      - 2.2.1.10 Strategic Undergrounding (WMP.473) ..... 26
      - 2.2.1.11 Distribution Overhead System Hardening (WMP.475) ..... 26
      - 2.2.1.12 Distribution Overhead Detailed Inspections (WMP.478) ..... 27
      - 2.2.1.13 Transmission Overhead Detailed Inspections (WMP.479) ..... 27
      - 2.2.1.14 Distribution Infrared Inspections (WMP.481)..... 27

2.2.1.15	Transmission Infrared Inspections (WMP.482).....	28
2.2.1.16	Distribution Wood Pole Intrusive Inspections (WMP.483).....	28
2.2.1.17	LiDAR Inspections of Distribution Electric Lines and Equipment (WMP.484).....	28
2.2.1.18	Transmission Overhead Patrol Inspections (WMP.489).....	29
2.2.1.19	QA/QC of Distribution Detailed Inspections (WMP.491).....	29
2.2.1.20	Transmission Overhead Hardening (WMP.543).....	29
2.2.1.21	Transmission Overhead Hardening – Distribution Underbuild (WMP.545).....	30
2.2.1.22	Distribution Communications Reliability Improvements (WMP.549).....	30
2.2.1.23	HFTD Tier 3 Distribution Pole Inspections (WMP.551).....	31
2.2.1.24	Drone Assessments (WMP.552).....	31
2.2.1.25	Avian Protection (WMP.972).....	31
2.2.1.26	Cleveland National Forest Overhead (Distribution Underground) (WMP.1016).....	32
2.2.1.27	Cleveland National Forest Overhead (Distribution Overhead) (WMP.1017).....	32
2.2.1.28	Strategic Pole Replacement Program (WMP.1189).....	32
2.2.1.29	Transmission Wood Pole Intrusive Inspections (WMP.1190).....	33
2.2.1.30	QA/QC of Wood Pole Intrusive (Transmission and Distribution) (WMP.1193).....	33
2.2.1.31	Early Fault Detection (WMP.1195).....	33
2.2.2	Vegetation Management and Inspection.....	33
2.2.2.1	Detailed Vegetation Inspections (WMP.494).....	33
2.2.3	Situational Awareness and Forecasting.....	34
2.2.3.1	Weather Station Network and NDVI Cameras (WMP.447).....	34
2.2.3.2	Fire Potential Index (WMP.450).....	34
2.2.3.3	Air Quality Management Program (WMP.970).....	34
2.2.4	Emergency Preparedness.....	35
2.2.4.1	Aviation Firefighting Program (WMP.557).....	35
2.2.4.2	Public Emergency Communication Strategy (WMP.563).....	35
2.2.4.3	Emergency Preparedness (WMP.1008).....	35
2.2.5	Community Outreach and Engagement.....	36
2.2.5.1	Public Outreach and Education Awareness (WMP.527).....	36
2.2.6	Public Safety Power Shutoff.....	36
2.2.7	Mitigation Strategy Development.....	36
2.2.7.1	Risk Assessment and Mapping (WMP.442).....	36
2.2.7.2	WMP Data Platform (WMP.519).....	36
2.2.7.3	Allocation Methodology Development and Application (WMP.523).....	37
<b>3</b>	<b>Quarterly Inspection Targets for 2025.....</b>	<b>38</b>
<b>4</b>	<b>New or Discontinued Programs.....</b>	<b>40</b>
4.1	New Programs.....	40
4.1.1	Weather Station Maintenance and Calibration (WMP.1430).....	40
4.1.2	Air Quality Station Maintenance (WMP.1431).....	40
4.2	Discontinuance of a Program.....	40
<b>5</b>	<b>Progress on Areas for Continued Improvement.....</b>	<b>41</b>
5.1	SDGE-23-01: Cross-Utility Collaboration on Risk Model Development.....	41
5.2	SDGE-23-02: Calculating Risk Scores Using Maximum Consequence Values.....	42

5.3	SDGE-23-03: PSPS and Wildfire Risk Trade-Off Transparency .....	45
5.3.1	PSPS Risk Prioritization in Risk-Based Decisions .....	45
5.3.2	Comparison of Planned Mitigation Initiative Rank Order with Risk Buy-Down Estimate Rank Order .....	47
5.4	SDGE-23-04: Incorporation of Extreme Weather Scenarios into Planning Models.....	51
5.5	SDGE-23-05: Cross-Utility Collaboration on Best Practices for Inclusion of Climate Change Forecasts in Consequence Modeling, Inclusion of Community Vulnerability in Consequence Modeling, and Utility Vegetation Management for Wildfire Safety .....	51
5.5.1	Inclusion of Climate Change Forecasts in Consequence Modeling .....	52
5.5.2	Inclusion of Community Vulnerability in Consequence Modeling.....	52
5.5.3	Utility Vegetation Management for Wildfire Safety .....	52
	SDGE-23-06: Demonstration of Proper Decision Making for Selection of Undergrounding Projects ....	53
5.5.4	Interim Mitigation Strategies for Risk Reduction.....	55
5.5.5	Selection Process for Undergrounding Projects .....	56
5.5.5.1	Location-Specific Ignition Driver Analysis .....	59
5.5.5.2	Effectiveness of Undergrounding versus other Mitigations .....	59
5.5.5.3	Cumulative Risk Exposure of the Mitigation Initiative Portfolio .....	60
5.5.5.4	Incorporating PSPS Risk in Mitigation Selection .....	61
5.5.5.5	Visualization of Wildfire Risk.....	64
5.5.6	Adjustment to Hardening Scope .....	64
5.6	SDGE-23-07: Third-Party Recommendations for Model Improvements .....	65
5.6.1	Inclusion of Vegetation Risk Analytics for Vegetation Operational Decisions.....	66
5.6.2	Use of Risk Model to Inform Mitigation Work Outside of Grid Hardening.....	67
5.6.3	Sensitivity Analysis .....	67
5.6.4	Elimination of Double-Counting of Conductor Age and Circuit Health Index.....	67
5.6.5	Third Party Review Recommendations.....	68
5.7	SDGE-23-08: Continuation of Grid Hardening Joint Studies .....	85
5.7.1	Joint IOU Covered Conductor Working Group Report.....	86
5.7.2	SDG&E Response.....	88
5.8	SDGE-23-09: New Technologies Evaluation and REFCL Implementation .....	93
5.9	SDGE-23-10: Early Fault Detection Implementation.....	94
5.10	SDGE-23-11: Changes to Scope of Falling Conductor Protection Program.....	95
5.11	SDGE-23-12: Covered Conductor Inspection and Maintenance.....	98
5.12	SDGE-23-13: QA/QC for Inspections .....	99
5.13	SDGE-23-14: Equipment Maintenance and Repair Maturity Level.....	100
5.14	SDGE-23-15: Evaluation of Sensitive Relay Profile in Highest Risk Areas .....	101
5.15	SDGE-23-16: Updates on Identifying Additional, Proactive HFTD Inspections.....	102
5.16	SDGE-23-17: Continuation of Effectiveness of Enhanced Clearances Joint Study.....	103
5.16.1	Aligned Vegetation Risk Event Variables .....	104
5.16.2	Description of Database Type and Architecture .....	106
5.16.3	Incorporation of Biotic and Abiotic Factors .....	108
5.16.4	Third-Party Contractor’s Assessment of the Effectiveness of Enhanced Clearances .....	108
5.16.5	Progress on the Evaluation of Enhanced Clearances and Recommendations.....	108
5.17	SDGE-23-18: Update Targets Table with Planned Improvements’ Measurable Targets.....	108

5.18	SDGE-23-19: Weather Station Maintenance and Calibration .....	109
------	---	-----

## List of Tables

---

Table 1: Top 5% Wildfire Risk Circuits/Segments/Spans .....	5
Table 2: Top 5% PSPS Risk Circuits/Segments/Spans .....	6
Table 3: WiNGS-Planning Qualitative Risk Modeling Updates .....	7
Table 4: WiNGS-Ops Risk Modeling Qualitative Updates .....	10
Table 5: Changes in Objective Completion Dates .....	15
Table 6: Qualifying Changes in Targets and Expenditures (in Thousands) .....	20
Table 7: Qualifying Changes in Expenditures only (in Thousands) .....	21
Table 8: Asset Inspections and Vegetation Management Targets for 2025 .....	38
Table 9: WiNGS-Planning Cost/Benefit Transition Plan .....	44
Table 10: Ranking of Planned Mitigation Initiatives .....	48
Table 11: MAVF Attribute Calculations for PSPS CoRE .....	63
Table 12: WiNGS-Planning Output Comparison .....	65
Table 13: WiNGS-Planning Third Party Recommendations .....	68
Table 14: WiNGS-Ops Third Party Recommendations .....	74
Table 15: Efficacy of Covered Conductor .....	89
Table 16: Efficacy of Covered Conductors with or without Combined Mitigations.....	92
Table 17: Descoped FCP Projects .....	96
Table 18: SRP Analysis Results .....	102
Table 19: Common Vegetation Management Variables.....	104
Table 20: Weather Stations Unable to Undergo Annual Maintenance .....	110

## List of Figures

---

Figure 1: High-Level Mitigation Prioritization to Reduce Wildfire and PSPS Risk .....	46
Figure 2: Long-Term Risk Reduction Approach.....	54
Figure 3: Hierarchy of Risk Controls.....	55
Figure 4: Effectiveness of Hardening Strategies to Wildfire Risk (Years 2007-2023) .....	56
Figure 5: WiNGS-Planning Mitigation Decision Tree .....	57
Figure 6: High-Level Mitigation Prioritization to Reduce Wildfire and PSPS Risk .....	58
Figure 7: WiNGS-Planning Ignition Rate Normalization Process .....	59
Figure 8: Projected PSPS Impact Reduction.....	60
Figure 9: Annual Expected Risk Reduction (Years 2022-2031) .....	61
Figure 10: WiNGS-Planning Calculation Schematic.....	62
Figure 11: WiNGS-Planning Visualization Platform.....	64
Figure 12: Hardening Efficacy Over Time .....	91
Figure 13: SQL Database Scheme.....	107

## List of Appendices

---

Appendix A: REFCL Impact Study for Descanso Substation

Appendix B: Weather Station Maintenance and Calibration

## List of Abbreviations

---

<b>Abbreviation</b>	<b>Name</b>
AAR	After action review
ACI	Area of Continued Improvement
AFN	Access and Functional Needs
AQI	Air Quality Index
AWS	Amazon Web Services
CAL FIRE	California Department of Forestry and Fire Protection
CBR	Cost-Benefit Ratio
CHI	Circuit Health Index
CMP	Corrective Maintenance Program
CoRE	consequence of a risk event
CPUC	California Public Utilities Commission
CSV	Comma Separated Value
DCRI	Distribution Communications Reliability Improvements
EEl	Edison Electric Institute
EFD	Early Fault Detection
EPRO	Electric Power Research Institute
ETL	an Extract Translate and Load
FCP	Falling Conductor Protection
FERC	Federal Energy Regulatory Commission
FPI	Fire Potential Index
FTS	Forest Technology Systems
GAP	Generator Assistance Program
GGP	Generator Grant Program
GIS	geographic information system
GRC	General Rate Case
HFTD	High Fire Threat District
HLC	Hotline Clamp
IOU	Investor-Owned Utility
IWRMC	International Wildfire Risk Mitigation Consortium

<b>Abbreviation</b>	<b>Name</b>
km	kilometer
kV	Kilovolt
LiDAR	Light detection and ranging
LoRE	Likelihood of risk event
MAVF	multi-attribute value function
NDVI	Normalized Difference Vegetation Index
NWS	National Weather Service
O&M	Operations & Maintenance
OEIS or Energy Safety	Office of Energy Infrastructure Safety
OIR	Order Instituting Rulemaking
PG&E	Pacific Gas & Electric
PoF	existing Probability of Failure
PoI	Probability of Ignition
PSPF	Public Safety Partner Portal
PSPS	Public Safety Power Shutoff
O&M	Operations & Maintenance
QA/QC	Quality Assessment/Quality Control
QDR	Quarterly Data Report
RAMP	Risk Assessment Mitigation Phase
RDF	Risk-Based Decision-Making Framework
RDS	Relational Database Services
REFCL	Rapid Earth Fault Current Limiter
RFS	Remove From Service
RMWG	risk modeling working group
RSE	Risk Spend Efficiency
SCADA	supervisory control and data acquisition
SCE	Southern California Edison
SDG&E	San Diego Gas & Electric
SDSC	San Diego Supercomputer Center
SGF	sensitive ground faults
SHAP	Shapley Additive Explanations
SIF	Serious Injuries and Fatalities
SPACE	System Protection and Controls Engineering
SRP	sensitive relay profile
SVI	Social Vulnerability Index

<b>Abbreviation</b>	<b>Name</b>
TVaR	tail-value-at-risk
UCSD	University of California at San Diego
VRI	Vegetation Risk Index
WFA	Wildfire Analyst
WFI	Wireless Fault Indicator
WiNGS	Wildfire Next Generation System
WMP	Wildfire Mitigation Plan
WRRM	Wildfire Risk Reduction Model
WUI	Wildland Urban Interface



## Introduction

---

In 2023, San Diego Gas & Electric submitted its 2023-2025 Wildfire Mitigation Plan to the Office of Energy Infrastructure Safety (OEIS or Energy Safety). In 2024, each electrical corporation must provide an update to its approved 2023-2025 Wildfire Mitigation Plan as outlined in the 2025 Wildfire Mitigation Plan Update Guidelines<sup>1</sup>.

This 2025 Wildfire Mitigation Plan (WMP) Update provides updates and information on initiatives, objectives, and targets listed in the 2023-2025 Wildfire Mitigation Plan. Section 1 contains updates on the risk models used to aid the scoping of grid hardening initiatives and guide risk-based de-energization. Section 2 discusses any changes in objectives, targets, or expenditures that meet the OEIS threshold. Section 3 provides updates for 2025 quarterly inspection targets. Section 4 describes two new initiatives. Section 5 provides progress on Areas for Continued Improvement (ACIs).

SDG&E continues to innovate and improve wildfire mitigation initiatives to promote community safety through enhancing risk-informed strategies, advancing technology integration, and continuing stakeholder engagement. In 2023, significant strides were made to enhance risk modeling capabilities. These improvements continue to inform and refine the Company's mitigation investment strategies and initiative selections, and optimize the ability to pinpoint mitigations to areas with the highest wildfire and PSPS risk. For example, the WiNGS-Planning model underwent updates, reinforcing efforts to support hardening strategy and scoping efforts. These updates included architectural enhancements and a series of automated data verification improvements, along with output validation analyses. Additionally, data governance and architecture within the WiNGS-Planning model was enhanced, emphasizing reliability, standardization, and transparency. Ultimately, these efforts lead to more accurate insights and empower risk-informed investment decision-making.

SDG&E's efforts towards advancing technology integration include continuous evaluation and implementation of new technologies, further advancing data science methodologies to improve predictive analytics and explore further automation of fire detection capabilities. Finally, wildfire mitigation and preparedness are community efforts that span disciplines, jurisdictions, and tools; therefore, stakeholder engagement continues to be a key component of the WMP. SDG&E aims to expand collaboration with academia and agencies to continue to support communities and protect customers from the risks of wildfire and PSPS impacts.

---

<sup>1</sup> 2025 Wildfire Mitigation Plan Update Guidelines; <https://energysafety.ca.gov/what-we-do/electrical-infrastructure-safety/wildfire-mitigation-and-safety/wildfire-mitigation-plans/2025-wildfire-mitigation-plans/>

# 1 Updates to Risk Models

---

## 1.1 Significant Updates

---

The OEIS defines significant updates as any change or combination of changes to the risk model that moves 10% or more of the ignition risk and/or Public Safety Power Shutoff (PSPS) risk in or out of the top 5% of highest risk circuits/segments /spans when all circuits/segments/ spans are ranked individually from highest to lowest risk.<sup>2</sup> This definition excludes shifts in risk resulting from the implementation of mitigation measures since the filing of the Base WMP, allowing for an “apples to apples” comparison over the course of the WMP cycle.

SDG&E uses two risk models to inform wildfire and PSPS risk mitigation. The first model, Wildfire Next Generation System (WiNGS)-Planning, aids in the scoping and planning of grid hardening initiatives across High Fire Threat District (HFTD) circuit segments based on an assessment of both wildfire risk and PSPS impacts. Its evaluation informs investment decisions by determining which initiatives maximize the benefit per dollar spent in reducing both wildfire risk and PSPS impact.

The second model, WiNGS-Ops, is a real-time decision-making tool built to evaluate and compare wildfire and PSPS risks at the asset level (pole/span) and the sub-circuit/segment level. WiNGS-Ops helps guide risk-based de-energization decisions during extreme fire weather conditions based on available data.

Updates made to the WiNGS-Planning and WiNGS-Ops platforms and wildfire and PSPS models and sub-models are categorized into the following key areas:

- **Model Enhancements:** Improvements and advancements made to existing models, focusing on refining their accuracy, capabilities, or features to enhance their overall performance, auditability, and utility.
- **Data Governance and Data Architecture:** Enhancements made to refine the management of data, incorporating robust governance practices and optimizing the overall architecture. These changes aim to enhance traceability, efficiency, and organizational structure.
- **Model Validation and User Acceptance:** Validation of existing risk models to ensure their accuracy and applicability and assessment of user acceptance to ensure that the models meet the needs and expectations of internal and external users.
- **Visualization Platform:** Development, improvement, and/or optimization of tools and interfaces used for visualizing data and insights, ensuring effective communication and understanding of Wildfire and PSPS risk information.

These updates are primarily influenced by factors identified in:

- ACIs (see Section 5)

---

<sup>2</sup> 2025 Wildfire Mitigation Plan Update Guidelines, Section 1.1.1

- 2023 Electrical Corporation Wildfire Mitigation Maturity Model Survey<sup>3</sup>
- Utility Risk Assessment Improvement Plan<sup>4</sup>
- Third Party Independent review

## WiNGS-Planning

In 2023, the WiNGS-Planning model was updated with the objective of reinforcing the model to support scoping efforts, which involved architectural updates as well as a series of automated data verification improvements and output validation analyses. The resulting version 3.0 of the model was used to develop PSPS and wildfire risk ranking of circuit segments, as shown in Table 1 and Table 2. Version 3.0 is the current model in use to scope work beginning in 2027.

In 2024, SDG&E plans to enhance the existing model (version 3.0), and progress to the next iteration. The primary focus of this year’s development cycle is to elevate the overall risk methodology to reflect the cost-benefit approach<sup>4</sup> to align with RAMP requirements, refine key input data and assumptions, enhance model granularity, and improve risk presentation. This, in turn, will expand the model's capacity to recommend effective long-term mitigations at the circuit segment level. Two major model releases are expected to occur sometime between mid-2024 to early 2025 to accommodate the changes listed above. Model version control details can be found in the 2023-2025 Wildfire Mitigation Plan.<sup>5</sup> Table 3 details qualitative updates to the current WiNGS-Planning model (version 3.0) and improvements to the model's foundation, architecture, pipelines, and modularity to accommodate the upcoming model releases.

Extensive analyses were performed comparing the WiNGS-Planning model presented in the 2023-2025 Wildfire Mitigation Plan to the current production model (version 3.0) to determine if updates were significant or non-significant as defined by the OEIS. Between the two model versions, wildfire risk changed by approximately 2% and PSPS risk changed by 2% within the top 5% of segments when segments were ranked by wildfire risk (as shown in Table 1), which would categorize updates as non-significant. However, when segments were ranked by PSPS risk (as shown in Table 2), PSPS risk changed approximately 50% for the top 5% of segments, which would categorize updates as significant.

The following significant updates were made to the WiNGS-Planning model:

### 1. Upgrade PSPS Likelihood of Risk Event (LoRE) Risk Assessment

**Updated Methodology and Models:** This model enhancement update was performed in response to Key Risk Assessment Area RA-1-A<sup>4</sup>. It implemented 4 kilovolt (kV) to 12 kV connectivity to account for circuit segment dependencies, leading to a more precise representation of PSPS risk upstream of 4 kV circuit segments.

<sup>3</sup> 2023 Electrical Corporation Wildfire Mitigation Maturity Survey.  
<https://efiling.energysafety.ca.gov/eFiling/Getfile.aspx?fileid=53395&shareable=true>

<sup>4</sup> 2023-2025 Wildfire Mitigation Plan, Section 6.7; [https://www.sdge.com/sites/default/files/regulatory/2023-2025%20SDGE%20WMP%20with%20Attachments\\_Errata\\_10-23-23.pdf](https://www.sdge.com/sites/default/files/regulatory/2023-2025%20SDGE%20WMP%20with%20Attachments_Errata_10-23-23.pdf)

<sup>5</sup> 2023-2025 Wildfire Mitigation Plan, Section 6.6.2.3 and SDGE Table 6-9

**Justification:** Previously, 4 kV circuits were disconnected from their feeding 12 kV circuit segments. Prior to the change, the only attribute available to account for a 4 kV circuit's upstream 12 kV circuit was the circuit ID, which affected the model by generalizing the upstream PSPS LoRE.

**Shift in Risk:** This enhancement affected PSPS LoRE and variables calculated using PSPS LoRE. The updated model connects parent and child feeders together and assesses their connectivity more accurately, thereby improving current PSPS LoRE risk assessment. As a result, 206 4 kV circuit segments are now connected to their 12 kV upstream circuit segment counterparts. On average, PSPS LoRE was reduced by a rate of 0.16.

**Resulting Prioritization Changes:** None

## 2. Update Weather Station Wind Gust Attribute

**Updated Methodology and Models:** This model enhancement update was performed in response to Key Risk Assessment Area RA-1-A<sup>6</sup>. Revision of historical weather station data during fire season periods has influenced historical wind gust values for circuit segments, consequently impacting the calculation of PSPS LoRE.

**Justification:** As part of the annual process to refresh the weather station statistics utilized throughout the fire season, certain historical wind gust thresholds and the association between weather stations and supervisory control and data acquisition (SCADA) Sectionalizing Devices were revised. These modifications impacted the computation of PSPS LoRE within the WiNGS-Planning model.

**Shift in Risk:** The maximum wind gust variable was reduced by an average of 1.7 miles per hour, which had downstream effects on PSPS LoRE.

**Resulting Prioritization Changes:** None

## 3. Enable Dynamic Upstream Tracing to Calculate Maximum Upstream PSPS Probability

**Updated Methodology and Models:** This model enhancement update was performed in response to Key Risk Assessment Area RA-1-B<sup>6</sup>. The update implemented dynamic upstream tracing to enhance the accuracy of upstream PSPS probability estimates for each sectionalizing device.

**Justification:** PSPS probability was a derived value that required a manual assessment from Meteorology. Network tracing now dynamically assesses the risk upstream of each circuit segment and dynamically calculates the PSPS LoRE for each segment.

**Shift in Risk:** This enhancement affected PSPS LoRE and variables calculated using PSPS LoRE. By design, PSPS LoRE is now dynamically shifted upstream or downstream when a segment is mitigated.

**Resulting Prioritization Changes:** None

Qualitative updates to WiNGS-Planning can be found in Table 3.

---

<sup>6</sup> 2023-2025 Wildfire Mitigation Plan, Section 6.7

## WiNGS-Ops

The WiNGS-Ops model quantifies the risk of two scenarios, proactive de-energization versus wildfire safety risks to the public, following the enterprise risk quantification framework, which uses a multi-attribute value function (MAVF) to quantify risk<sup>7</sup> (see Section 6.1.1 of the 2023-2025 Wildfire Mitigation Plan for Enterprise consequence of a risk event [CoRE] MAVF Attributes<sup>8</sup>).

The main objective of this tool is to inform de-energization decisions on a segment-by-segment basis. For segments identified as potential candidates for a PSPS de-energization, the WiNGS-Ops model quantifies and compares the risk of wildfire and PSPS risk and identifies wind gust thresholds at which de-energization would reduce the risk of wildfire and promote public safety. The comparative assessments of wildfire and PSPS risks are calculated from segment-specific criteria and include factors such as weather, customers, assets, enterprise assumptions, and event-specific assumptions.

The most recent assumptions regarding wildfire and PSPS risk can be located in SDG&E's PPS Post-Event Report.<sup>9</sup>

Updates to WiNGS-Ops were qualitative and can be found in Table 4.

### 1.1.1 Top Risk-Contributing Circuit, Segments, or Spans

Table 1 shows the updated top 5% of highest wildfire risk segments and Table 2 shows the updated top 5% of highest PPS risk segments. In addition, wildfire and PPS ratios are included to illustrate the comparative magnitude of their respective values at the circuit segment level. Wildfire risk represents the overall anticipated annualized consequences resulting from simulated ignitions at a particular location, while PPS risk denotes the total expected annualized impacts on customers downstream of each sectionalizing device arising from de-energization events.

**Table 1: Top 5% Wildfire Risk Circuits/Segments/Spans**

Risk Rank	Feeder ID	Segment ID	Wildfire Risk Score	PSPS Risk Score	Wildfire / PSPS Ratio	% of Total Wildfire Risk in Top 5%
1	237	237-30R	7.01E-03	1.25E-04	55.88	9.09%
2	909	909-805R	6.99E-03	6.57E-05	106.30	9.06%
3	222	222-1401R	6.76E-03	1.51E-04	44.85	8.77%
4	524	524-69R	5.36E-03	1.03E-04	52.26	6.95%
5	222	222-1364R	4.57E-03	3.01E-04	15.17	5.93%
6	448	448-11R	3.07E-03	3.53E-04	8.71	3.99%
7	217	217-983R	2.95E-03	4.80E-05	61.41	3.82%

<sup>7</sup> The Enterprise Risk Management Framework is based on the Settlement Agreement (SA) that the utilities and intervenors reached in the Safety Model Assessment (S-MAP) proceeding and which was adopted by the CPUC as the guiding framework for conducting risk assessments for RAMP. This structure was used in quantifying and analyzing the RAMP Risks. For further information reference: [https://www.sdge.com/sites/default/files/regulatory/RAMPC\\_SDGE%20FINAL%2011%202027.pdf](https://www.sdge.com/sites/default/files/regulatory/RAMPC_SDGE%20FINAL%2011%202027.pdf)

<sup>8</sup> 2023-2025 Wildfire Mitigation Plan, Section 6.1.1

<sup>9</sup> PPS Post-Event Report, Section 2 – Decision Making Process; <https://www.cpuc.ca.gov/-/media/cpuc-website/divisions/safety-and-enforcement-division/reports/psps-post-event-reports/2023/r1812005-sdge-psps-postevent-report-oct-2931-2023-11-14-2023.pdf>

Risk Rank	Feeder ID	Segment ID	Wildfire Risk Score	PSPS Risk Score	Wildfire / PSPS Ratio	% of Total Wildfire Risk in Top 5%
8	222	222-1370R	2.81E-03	2.76E-04	10.16	3.64%
9	358	358-682F	2.74E-03	2.08E-04	13.16	3.55%
10	157	157-81R	2.49E-03	1.01E-04	24.51	3.22%
11	1030	1030-989R	2.44E-03	7.34E-05	33.30	3.17%
12	79	79-808R	2.22E-03	6.65E-05	33.38	2.88%
13	73	73-643R	2.21E-03	1.96E-04	11.26	2.86%
14	237	237-1765R	2.16E-03	9.30E-05	23.27	2.81%
15	214	214-1122R	2.13E-03	1.11E-04	19.11	2.76%
16	1215	1215-32R	1.99E-03	1.01E-04	19.64	2.58%
17	237	237-17R	1.89E-03	2.53E-04	7.48	2.45%
18	220	220-298R	1.89E-03	1.47E-04	12.80	2.45%
19	217	217-837R	1.77E-03	2.10E-04	8.45	2.29%
20	73	73-683R	1.75E-03	9.63E-05	18.14	2.27%
21	157	157-232R	1.72E-03	2.65E-04	6.47	2.22%
22	445	445-1311R	1.55E-03	1.76E-04	8.77	2.01%
23	235	235-899R	1.53E-03	2.32E-04	6.58	1.98%
24	222	222-2013R	1.49E-03	1.08E-04	13.80	1.93%
25	521	521-14R	1.49E-03	1.46E-04	10.21	1.93%
26	970	970-1341R	1.40E-03	1.96E-04	7.14	1.81%
27	217	217-835R	1.40E-03	4.00E-05	34.92	1.81%
28	216	216-1857	1.38E-03	4.45E-05	31.01	1.79%

**Table 2: Top 5% PSPS Risk Circuits/Segments/Spans**

Risk Rank	Feeder ID	Segment ID	Wildfire Risk Score	PSPS Risk Score	Wildfire / PSPS Ratio	% of Total PSPS Risk in Top 5%
1	442	442-728R	7.71E-05	6.44E-04	0.12	6.39%
2	975	975-22R	3.88E-04	5.40E-04	0.72	5.36%
3	972	972-8	4.07E-04	5.35E-04	0.76	5.30%
4	214	214-583R	9.67E-05	5.13E-04	0.19	5.09%
5	221	221-1230F	3.53E-04	4.51E-04	0.78	4.47%
6	597	597-595	3.30E-04	4.29E-04	0.77	4.26%
7	441	441-23R	7.26E-04	4.29E-04	1.69	4.25%
8	176	176-1834R	1.21E-04	4.03E-04	0.30	4.00%
9	79	79-785	5.50E-04	4.00E-04	1.37	3.97%

Risk Rank	Feeder ID	Segment ID	Wildfire Risk Score	PSPS Risk Score	Wildfire / PSPS Ratio	% of Total PSPS Risk in Top 5%
10	214	214-536R	9.46E-06	3.93E-04	0.02	3.90%
11	441	CB 441	3.57E-04	3.92E-04	0.91	3.89%
12	448	448-11R	3.07E-03	3.53E-04	8.71	3.50%
13	79	79-676R	1.51E-04	3.48E-04	0.43	3.46%
14	79	79-1215F	8.39E-06	3.48E-04	0.02	3.46%
15	157	157-189R	1.25E-03	3.22E-04	3.90	3.19%
16	222	222-1364R	4.57E-03	3.01E-04	15.17	2.99%
17	79	79-714R	8.42E-05	2.95E-04	0.29	2.92%
18	393	393-14R	3.01E-05	2.83E-04	0.11	2.81%
19	448	448-33R	2.68E-04	2.82E-04	0.95	2.80%
20	1234	CB 1234	4.61E-04	2.77E-04	1.66	2.75%
21	214	214-613R	1.15E-05	2.77E-04	0.04	2.74%
22	222	222-1370R	2.81E-03	2.76E-04	10.16	2.74%
23	396	CB 396	2.18E-07	2.75E-04	0.00	2.73%
24	79	79-658R	2.23E-04	2.71E-04	0.82	2.69%
25	157	157-232R	1.72E-03	2.65E-04	6.47	2.63%
26	176	176-161R	6.29E-05	2.63E-04	0.24	2.61%
27	1030	1030-42R	1.02E-03	2.59E-04	3.94	2.57%
28	221	221-37AE	2.60E-04	2.55E-04	1.02	2.53%

### 1.1.2 Qualitative Updates

Qualitative updates for the WiNGS-Planning and WiNGS-Ops models are included in Table 3 and Table 4, respectively.

**Table 3: WiNGS-Planning Qualitative Risk Modeling Updates**

	Key Area	Update	Benefit of Update	Source for Update	Status*
1	Model enhancements	Automate hardening-informed PSPS wind speed threshold assessment	Automate the calculation process for PSPS wind speed thresholds, aligning with specific hardening types. This automation introduces efficiency, accuracy, and adaptability to different hardening strategies, streamlining the overall process and contributing to more effective PSPS risk quantification.	<ul style="list-style-type: none"> <li>Key Risk Assessment Area RA-1-A**</li> </ul>	Complete

	Key Area	Update	Benefit of Update	Source for Update	Status*
2	Model Enhancements	Update starting constants	Update starting constants with the latest available information based on subject matter expertise and the latest study results. Constants updated include PSPS calibration factor, wildfire frequency rate, wind speed thresholds for hardening types, fire season starting month, and underground to Remove From Service (RFS) ratio	<ul style="list-style-type: none"> <li>• Key Risk Assessment Area RA-1-A**</li> <li>• Third-party review recommendations</li> </ul>	Complete
3	Model Enhancements	Incorporate Social Vulnerability Index (SVI)	Conduct research and development to integrate social vulnerability data into both the wildfire CoRE and PSPS CoRE risk assessments. This initiative seeks to enrich the risk assessment process by incorporating insights from social vulnerability metrics, seeking to promote equity in evaluation of potential impacts on communities during both wildfire and PSPS de-energizations.	<ul style="list-style-type: none"> <li>• Key Risk Assessment Area RA-1-A**</li> <li>• Third-party review recommendations</li> <li>• 2023-2025 WMP Technical Guidelines</li> <li>• Maturity Model: Risk Assessment and Mitigation Strategy</li> </ul>	In progress
4	Model Enhancements	Update tree strike model	Update tree strike model to encapsulate entire service territory. Add additional filters to remove trees which are below typical pole height.	<ul style="list-style-type: none"> <li>• Key Risk Assessment Area RA-1-B**</li> <li>• Third-party review recommendations</li> </ul>	In progress
5	Model Enhancements	Incorporate egress when evaluating wildfire risk	Develop an egress impact factor to integrate into the Wildfire CoRE calculation. This enhancement will assess added wildfire consequence risk relating to customer egress impacts.	<ul style="list-style-type: none"> <li>• Key Risk Assessment Area RA-1-A**</li> <li>• Third-party review recommendations</li> <li>• Maturity Model: Risk Assessment and Mitigation Strategy</li> </ul>	In progress
6	Model Enhancements	Initiate scenario analysis for different wind conditions	Research and development on the wind speed percentiles and how they affect downstream mitigation recommendations.	<ul style="list-style-type: none"> <li>• Key Risk Assessment Area RA-2-A**</li> </ul>	In progress
7	Model Enhancements	Evaluate probability distributions instead of maximum values for consequence	Assess probability distributions for consequence of wildfire at the span and segment level. The span level considers the probability distributions created by Technosylva simulations. Each span-level simulation value within a segment forms the segment-level distribution. Both levels resulted in potentially using the so-called "tail-value-at-risk" (TVaR) for its benefit in summarizing and capturing distributional properties.	<ul style="list-style-type: none"> <li>• ACI SDGE-23-02 (see Section 5.2)</li> </ul>	In progress



	Key Area	Update	Benefit of Update	Source for Update	Status*
8	Model Enhancements	Retrain models and explore new methodologies	Expand existing collaboration with Moody's RMS to comprehend and assess their stochastic approach to fire consequence modeling. Integrating this methodology and inputs in the wildfire consequence model may lead to insights into long-duration fires that incorporate fire suppression activities.	<ul style="list-style-type: none"> <li>Key Risk Assessment Area RA-1-B and RA-3-B**</li> <li>Maturity Model: Risk Assessment and Mitigation Strategy</li> </ul>	In progress
9	Model Enhancements	Estimate of PSPS de-energization duration	Estimate PSPS de-energization duration and customer minutes impacted for each segment. Estimates include all customers and the medical baseline, Access and Functional Needs (AFN), and socially vulnerable subsets.	<ul style="list-style-type: none"> <li>Maturity Model: Risk Assessment and Mitigation Strategy</li> </ul>	In progress
10	Data Governance and Data Architecture	Refactor WiNGS-Planning aggregation functions	Convert Python functions from complex SQL statements into more efficient Python functions for improved readability, maintainability, and performance.	<ul style="list-style-type: none"> <li>Key Risk Assessment Area RA-1-B**</li> <li>Third-party review recommendations</li> </ul>	Complete
11	Data Governance and Data Architecture	Repoint flat files to Enterprise data sources	Shift data sourcing from flat files to Enterprise data sources whenever feasible. This shift will promote enhanced consistency through adherence to Enterprise quality assurance protocols, promoting reliability and standardized data management within the model.	<ul style="list-style-type: none"> <li>Key Risk Assessment Area RA-1-B**</li> <li>Third-party review recommendations</li> </ul>	Complete
12	Data Governance and Data Architecture	Implement parallelization of model run tasks	Refactor code to improve computational speed of the model by allowing parallel task runs.	<ul style="list-style-type: none"> <li>Key Risk Assessment Area RA-1-B**</li> </ul>	Complete
13	Data Governance and Data Architecture	Standardize model approach	Develop templates for standardizing the creation, validation, and deployment of models in cloud environments, aiming to streamline and expedite the modeling process. This initiative enhances efficiency, promotes consistency, and facilitates easier management of models, ultimately contributing to more effective decision-making and resource optimization within SDG&E's environments.	<ul style="list-style-type: none"> <li>Third-party review recommendations</li> </ul>	In progress
14	Data Governance and Data Architecture	Develop model documentation	Document the model including its technical and mathematical foundation, limitations, data libraries, and substantiation. This thorough documentation serves to provide clarity, transparency, and a reliable reference for understanding the model's structure, constraints, data sources, and the rationale behind its design and implementation.	<ul style="list-style-type: none"> <li>Data Governance Framework Guide</li> </ul>	Complete

	Key Area	Update	Benefit of Update	Source for Update	Status*
15	Data Governance and Data Architecture	Create/update technical model code with documentation	Populate doc strings with descriptive metadata for all python functions in the aggregations.py and ingest.py scripts to clarify the purpose and function of each code block.	<ul style="list-style-type: none"> <li>• Third-party review recommendations</li> </ul>	Complete
16	Data Governance and Data Architecture	Integrate span level risk scores	Upgrade model capabilities to conduct all calculations at span-level granularity. This improvement aims to provide a more detailed and precise analysis, allowing for a more accurate understanding of factors impacting the system at the span level.	<ul style="list-style-type: none"> <li>• Key Risk Assessment Area RA-1-B**</li> </ul>	In progress
17	Data Governance and Data Architecture	Expand to full-territory model	Upgrade model to generate risk scores for the entire service territory, including outside of the HFTD.	<ul style="list-style-type: none"> <li>• Key Risk Assessment Area RA-1-A**</li> </ul>	In progress
18	Data Governance and Data Architecture	Refactor WiNGS-Planning risk score functions	Develop code refactoring process to improve computational speed and functional dependencies of model risk calculation tasks.	<ul style="list-style-type: none"> <li>• Key Risk Assessment Area RA-1-B**</li> <li>• Third-party review recommendations</li> </ul>	In progress
19	Model Validation and User Acceptance	Formalize model validation and verification	Enhance the Pytest report to capture model deviations. Additionally, create validation notebooks to gauge the perceived accuracy of model inputs and outputs.	<ul style="list-style-type: none"> <li>• Key Risk Assessment Area RA-4-B**</li> <li>• Third-party review recommendations</li> </ul>	Complete
20	Visualization Platform	Continue improving and enhancing visualization platform	Continue to develop the WiNGS-Planning Visualization Platform.	<ul style="list-style-type: none"> <li>• Key Risk Assessment Area RA-5-A**</li> </ul>	In progress

\*Updates with a "Complete" status were performed on Version 3.0 of the model and updates with a "In progress" status are being performed on Version 4.0.

\*\*Reference 2023-2025 Wildfire Mitigation Plan, Section 6.7

**Table 4: WiNGS-Ops Risk Modeling Qualitative Updates**

#	Key Area	Update	Benefit of Update	Source Requirement	Status*
1	Model Enhancements	Model approach standardization	Develop templates for standardization and consistency in the creation, validation, and deployment of models in cloud environments.	<ul style="list-style-type: none"> <li>• Third-Party Review Recommendation</li> </ul>	In progress
2	Model Enhancements	Migrate historical weather station data to AWS	Integrate historical weather station records into Amazon Web Services (AWS) to reduce dependence on SAP HANA queries and Comma Separated Value (CSV) files, aiming for improved efficiency and data governance.	<ul style="list-style-type: none"> <li>• Key Risk Assessment Area RA-1-B**</li> <li>• Maturity Model</li> </ul>	Complete

#	Key Area	Update	Benefit of Update	Source Requirement	Status*
3	Model Enhancements	Retrain PoF and PoI models and explore new methodologies	Enhance the modularity and flexibility of the existing Probability of Failure (PoF) and Probability of Ignition (PoI) models to enable predictions beyond the boundaries of the HFTD.  Insights derived from model predictions could inform and enhance the delineation of HFTD boundaries.	<ul style="list-style-type: none"> <li>Key Risk Assessment Area RA-3-B**</li> </ul>	In progress
4	Model Enhancements	Retrain conductor model and explore new methodologies	Enhance the modularity and flexibility of the existing conductor model. Modify the current model code to ensure compatibility with AWS.	<ul style="list-style-type: none"> <li>Key Risk Assessment Area RA-1-B and RA-3-B**</li> <li>Third-Party Review Recommendation</li> </ul>	In progress
5	Model Enhancements	Retrain vehicle model and explore new methodologies	Enhance the modularity and flexibility of the existing vehicle model. Retrain the existing model by incorporating new features and observations from pad-mounted transformer assets. This expands the sample size and reduces sample imbalance.	<ul style="list-style-type: none"> <li>Key Risk Assessment Area RA-1-B and RA-3-B**</li> </ul>	Complete
6	Model Enhancements	Retrain vegetation model and explore new methodologies	Enhance the modularity and flexibility of the existing vegetation model by incorporating new features and observations to enhance the accuracy and predictability of the model. Also see ACI SDGE-23-07 (Section 5.6).	<ul style="list-style-type: none"> <li>Key Risk Assessment Area RA-1-B and RA-3-B**</li> </ul>	In progress
7	Model Enhancements	Retrain condition probability model and explore new methodologies	Collaborate with Technosylva to investigate the integration of Live Fuel Moisture (LFM) daily values into the existing condition probability of ignition model to enhance the accuracy and predictability of the model.  Develop a roadmap for enhancing the 2024 model and initiate the construction of data pipelines.	<ul style="list-style-type: none"> <li>Key Risk Assessment Area RA-1-B and RA-3-B**</li> <li>Third-Party Review Recommendation</li> </ul>	In progress
8	Model Enhancements	Retrain consequence model and explore new methodologies	Collaborate with Technosylva to create unsuppressed 24-hour fire simulations instead of 8-hour fire simulations to assess whether long-duration fires reveal risk areas that may not be identified by current models.	<ul style="list-style-type: none"> <li>Key Risk Assessment Area RA-1-B and RA-3-B**</li> </ul>	In progress

#	Key Area	Update	Benefit of Update	Source Requirement	Status*
9	Model Enhancements	Retrain consequence model and explore new methodologies	Expand existing collaboration with Moody's RMS to comprehend and assess their stochastic approach to fire consequence modeling. Integrating this methodology and inputs in the wildfire consequence model may lead to insights into long-duration fires that incorporate fire suppression activities.	<ul style="list-style-type: none"> <li>Key Risk Assessment Area RA-1-B and RA-3-B**</li> <li>Maturity Model: Risk Assessment and Mitigation Strategy</li> </ul>	In progress
10	Model Enhancements	Explore new weather forecast data sources	Collaborate with the San Diego Supercomputer Center (SDSC) to incorporate their weather forecasts, provided at a 1.5-kilometer (km) resolution, to enhance risk forecasting capabilities.	<ul style="list-style-type: none"> <li>Key Risk Assessment Area RA-1-B and RA-4-B**</li> </ul>	In progress
11	Model Enhancements	Incorporate wildfire spread forecasted consequence in PSPS decision-making	Develop an Extract Translate and Load (ETL) process for the daily ingestion of Technosylva's forecasted risk simulations into SDG&E's AWS. Generate visualizations to analyze daily risk within the service territory. Investigate the potential integration into the consequence model for further refinement.	<ul style="list-style-type: none"> <li>Maturity Model: Risk Assessment and Mitigation Strategy</li> </ul>	In progress
12	Data Governance and Data Architecture	Enhance model documentation	Improve transparency, reproducibility, and auditability by documenting data sources, data pipelines, and model development and use.	<ul style="list-style-type: none"> <li>Key Risk Assessment Area RA-1-B**</li> <li>Third-Party Review Recommendation</li> </ul>	Complete
13	Data Governance and Data Architecture	Improve visibility into data refresh process	Update dashboards to show update frequency for various ETL processes, charts, and graphs, enhancing transparency for end-users by clearly indicating the last update time of the data utilized in any calculation or visualization within the application.	<ul style="list-style-type: none"> <li>Key Risk Assessment Area RA-5-A**</li> <li>Third-Party Review Recommendation</li> </ul>	Complete
14	Data Governance and Data Architecture	Optimize model architecture and pipelines to allow for sensitivity analysis	Initiate enhancements to model architecture, review methodologies, and optimize feature engineering to facilitate in-depth sensitivity analysis and comprehensive assessment of uncertainties. This encompasses refining the model architecture for a detailed examination of its responses to diverse inputs and conditions, which will establish a robust framework to evaluate and comprehend uncertainties in model predictions.	<ul style="list-style-type: none"> <li>Key Risk Assessment Area RA-2-A**</li> </ul>	In progress

#	Key Area	Update	Benefit of Update	Source Requirement	Status*
15	Data Governance and Data Architecture	Improve model pipeline architecture to enhance efficiency, scalability, and overall performance	Implement Amazon Relational Database Services (RDS) as the data storage solution for the WiNGS-Ops visualization platform. Data will be better cached and indexed, allowing for a faster load and response time in the visualization web app for end users. RDS does not modify the data or alter its representation; rather, it functions solely as a performance and stabilization method.	<ul style="list-style-type: none"> <li>Key Risk Assessment Area RA-4-B and RA-5-A**</li> </ul>	Complete
16	Data Governance and Data Architecture	Document model	Document model including technical and mathematical foundation, limitations, data libraries, and substantiation.	<ul style="list-style-type: none"> <li>Data Governance Framework</li> </ul>	Complete
17	Model Validation and User Acceptance	Formalize model validation and verification	Implement a template-driven model validation process, facilitating a more formalized and comprehensive review.	<ul style="list-style-type: none"> <li>Key Risk Assessment Area RA-4-B**</li> <li>ACI SDGE-23-07 (see Section 5.6)</li> <li>Third-Party Review Recommendation</li> </ul>	Complete
18	Model Validation and User Acceptance	Enhance data validation process	Enhance the data validation process to encompass the identification and resolution of source data anomalies.	<ul style="list-style-type: none"> <li>Key Risk Assessment Area RA-4-B**</li> </ul>	Complete
19	Model Validation and User Acceptance	Subject matter expert model review	Institute regular meetings with internal subject matter experts to assess model updates, data sources, model predictions, and identify areas for improvement.	<ul style="list-style-type: none"> <li>Key Risk Assessment Area RA-4-B**</li> <li>Third-Party Review Recommendation</li> </ul>	Complete
20	Model Validation and User Acceptance	Track model error	Establish an internal tracking system for model issues and independent audit findings, promoting diligent monitoring of remediation efforts.	<ul style="list-style-type: none"> <li>Key Risk Assessment Area RA-4-B**</li> <li>Third-Party Review Recommendation</li> </ul>	In progress
21	Model Validation and User Acceptance	Develop a more comprehensive procedure and maintain third-party reviews for all models	Implement an independent third-party review process to conduct audits on data, models, and pipelines, ensuring quality of the models.	<ul style="list-style-type: none"> <li>Key Risk Assessment Area RA-4-A**</li> </ul>	In progress
22	Visualization Platform	Continue efforts to improve, expand, and enhance the visualization platform.	Enhance the visualization platform to facilitate quick and easy access to reliable data to inform de-energization decisions, faster initial loads, and overall stability of the platform.	<ul style="list-style-type: none"> <li>Key Risk Assessment Area RA-5-A**</li> </ul>	In progress
23	Visualization Platform	Expand existing visualizations	Identify potential enhancements for existing plots, tables, and graphs to elevate user experience and facilitate efficient risk information transfer.	<ul style="list-style-type: none"> <li>Key Risk Assessment Area RA-5-A**</li> </ul>	In progress

#	Key Area	Update	Benefit of Update	Source Requirement	Status*
24	Visualization Platform	Institute subject matter expert visualization review	Institute regular meetings with internal subject matter experts, visualization developers, and platform users to ensure the precision of displayed data, enhance existing visualizations, and pinpoint areas for improvement.	<ul style="list-style-type: none"> <li>Key Risk Assessment Area RA-5-A**</li> </ul>	In progress
25	Visualization Platform	Implement automatic integration of wildfire spread forecasting into the PSPS decision-making process.	Incorporate estimations of acres burned and structures destroyed by considering both worst-case fire weather scenarios and daily forecasted weather conditions. This integration serves to improve the decision-making process for PSPS de-energization.	<ul style="list-style-type: none"> <li>Key Risk Assessment Area RA-5-A and RA-1-A**</li> <li>Maturity Model: Situational Awareness and Forecasting</li> </ul>	In progress
26	Visualization Platform	Change data connections to APIs from extracts	Enhance the data pipeline needed for visualizations to enable data ingestion directly from APIs rather than relying on uploaded extracts. This modification aligns with SDG&E's emphasis on data governance and initiatives related to data structure.	<ul style="list-style-type: none"> <li>Key Risk Assessment Area RA-1-B**</li> </ul>	Complete
27	Visualization Platform	Expand details on customers	Improve the customer information report within the visualization platform to offer more detailed statistics for customers downstream of each sectionalizing device.	<ul style="list-style-type: none"> <li>Key Risk Assessment Area RA-5-A**</li> </ul>	Complete

\*Updates with a "Complete" status were performed on Version 3.0 of the model and updates with a "In progress" status are being performed on Version 4.0.

\*\*Reference 2023-2025 Wildfire Mitigation Plan, Section 6.7

## 1.2 Non-Significant Updates

The OEIS defines non-significant updates as any change or combination of changes to the risk model that does not meet the significant update criteria.<sup>10</sup> Collective updates to the WINGS-Planning and WINGS-Ops risk models were categorized as significant and are addressed in Section 1.1.

<sup>10</sup> 2025 Wildfire Mitigation Plan Update Guidelines, Section 1.2

## 2 Changes to Approved Targets, Objectives, and Expenditures

### 2.1 Objectives

Energy Safety defines changes in objectives as any change to forecasted initiative objective completion dates in the approved 2023-2025 Wildfire Mitigation Plan that shift an objective’s completion to a different compliance period.<sup>11</sup> This section outlines changes in objective completion dates that meet the OEIS threshold and provides justification for each change. Table 5 provides an at-a-glance view of all changes.

**Table 5: Changes in Objective Completion Dates**

Objective Number	Initiative Category	2023 3-Year Objective	Applicable Initiative(s), Tracking ID(s)	2023-2025 WMP Objective Completion Date	Updated 2025 WMP Objective Completion Date*
8.1.04	Grid Design, Operations, and Maintenance	Build 185 Base Stations to deploy a privately-owned LTE network.	Distribution Communications Reliability Improvements, WMP.549	12/31/2025	12/31/2033
8.1.07	Grid Design, Operations, and Maintenance	Install new CAL FIRE-approved power fuses to replace existing expulsion fuse equipment in the HFTD.	Expulsion Fuse Replacement, WMP.459	12/31/2023	12/31/2025
8.1.08	Grid Design, Operations, and Maintenance	Replace HLC connections that are connected directly to overhead primary conductors with compression connections.	Maintenance, repair, and replacement of connectors, including hotline clamps, WMP.464	12/31/2024	12/31/2028
8.1.11	Grid Design, Operations, and Maintenance	Test devices that have been installed and identify the devices that do not have sufficient signals and low batteries, so they can be replaced in 2024 and 2025 by new material/WFI devices.	Wireless fault indicators, WMP.449	12/31/2025	12/31/2028
8.1.16	Grid Design, Operations, and Maintenance	Complete Tier 3 overhead hardening efforts, continue work on Tier 2 hardening.	Overhead Transmission Hardening, WMP.543 Underground Transmission Hardening, WMP.544	Tier 3 – 12/31/2024 Tier 2 – 12/31/2024	Tier 3 – 12/31/2023 Tier 2 – 12/31/2027

<sup>11</sup> 2025 Wildfire Mitigation Plan Update Guidelines, Section 2.2

Objective Number	Initiative Category	2023 3-Year Objective	Applicable Initiative(s), Tracking ID(s)	2023-2025 WMP Objective Completion Date	Updated 2025 WMP Objective Completion Date*
8.3.15	Situational Awareness and Forecasting	Continue to replace and/or update existing weather stations to improve weather data and ultimately provide more accurate forecasting.	Weather Stations and NDVI Cameras, WMP.1430	12/25/2025	12/31/2099 (Ongoing)
8.4.02	Emergency Preparedness	Expand Emergency Management Operations by increasing staff dedicated to enhancing various emergency programs.	Personnel Qualifications, WMP.1335	06/30/2023	06/30/2025
8.4.10	Emergency Preparedness	Add one new state-of-the-art Tactical Mobile Command Trailer to the emergency fleet.	Personnel Qualifications, WMP.1335	09/30/2024	06/25/2025
8.4.11	Emergency Preparedness	Put two new state-of-the-art Incident Support Vehicles in service to support existing fleet in field incidents.	Personnel Qualifications, WMP.1335	12/31/2023	12/31/2025
8.4.12	Emergency Preparedness	Create new repository (software solution) for AARs (platform to share with Safety Services). Accessible to others to interact.	Public Outreach and Education Awareness Program, WMP.527	12/31/2023	12/31/2024
9.1.07	Public Safety Power Shutoff	Supplant VRI with a predictive model for the likelihood of vegetation related failures.	Risk Assessment Improvement Plan, WMP.1339	12/31/2023	12/31/2025

\*Objectives completed earlier than their estimated completion date are discussed in the 2023 Annual Report on Compliance (ARC)<sup>12</sup>

## 2.1.1 Grid Design, Operations, and Maintenance

### 2.1.1.1 Wireless Fault Indicators (WMP.449)

**Objective:** Test devices that have been installed and identify the devices that do not have sufficient signals and low batteries, so they can be replaced in 2024 and 2025 by new material/Wireless Fault Indicator (WFI) devices.

The objective completion date for WFIs was adjusted due to the pausing of the initiative. See Section 2.2.1.1 for change justification.

### 2.1.1.2 Expulsion Fuse Replacement (WMP.459)

**Objective:** Install new California Department of Forestry and Fire Protection (CAL FIRE)-approved power fuses to replace existing expulsion fuse equipment in the HFTD.

The completion date of this objective was adjusted to continue this initiative through the 2023-2025 WMP cycle. This objective was expected to be completed in 2023, however, there are approximately

<sup>12</sup> 2023 Annual Report on Compliance; <https://efiling.energysafety.ca.gov/Dockets.aspx?caseId=1253>



1,000 fuses that remain to be replaced with CAL FIRE-approved fuses. The extension of this program deadline is largely related to significant material supply chain concerns.

#### **2.1.1.3 Transmission System Hardening (WMP.543; WMP.544; WMP.545)**

Objective: Complete Tier 3 overhead hardening efforts, continue work on Tier 2 hardening.

Tier 3 overhead hardening was completed in 2023, one year early. Tier 2 overhead hardening is ongoing and this objective date is being modified to align with the Tier 2 forecasted completion date of 2027.

#### **2.1.1.4 Maintenance, repair, and replacement of connectors, including hotline clamps (WMP.464)**

Objective: Replace hotline clamps (HLC) connections that are connected directly to overhead primary conductors with compression connections.

Prior scope and targets for this initiative were based on estimates of potential HLCs requiring replacement. Through the use of IIP technology, SDG&E now has additional data regarding the scope of the HLC replacement project, with approximately 4,000 HLCs that remain to be replaced, and has adjusted the completion date accordingly.

#### **2.1.1.5 Distribution Communications Reliability Improvements (LTE) (WMP.549)**

Objective: Build 185 Base Stations to deploy a privately-owned LTE network

The completion date of this objective was adjusted to continue beyond the 2023-2025 WMP cycle for several reasons. The most significant factors are the challenges of transmission structure attachments and the use of a new distribution pole design that will use engineered mono-poles with communication equipment above the electric distribution wire. Technical details and workflow processes for scale-up are taking longer than expected across several project aspects, including electric engineering, civil engineering, work methods, and telecommunications. Therefore, original design estimations have been adjusted to accommodate for these workflow activities and durations.

### **2.1.2 Vegetation Management and Inspection**

There were no changes to Vegetation Management objective completion dates.

### **2.1.3 Situational Awareness and Forecasting**

#### **2.1.3.1 Weather Stations and Normalized Difference Vegetation Index Cameras (WMP.447)**

Objective: Continue to replace and/or update existing weather stations to improve weather data and ultimately provide more accurate forecasting.

The completion date of this objective was adjusted because the initiative evolved to an ongoing maintenance program to ensure existing weather stations are appropriately maintained. See Section 4.1 for additional information.

## 2.1.4 Emergency Preparedness

### 2.1.4.1 Public Outreach and Education Awareness Program (WMP.527)

Objective: Create new repository (software solution) for after action reviews (AARs) (platform to share with Safety Services). Accessible to others to interact.

The objective completion date for creating a new repository for AARs was delayed in order to examine future cost and staffing needs.

### 2.1.4.2 Personnel Qualifications (WMP.1335)

Objective: Expand Emergency Management Operations by increasing staff dedicated to enhancing various emergency initiatives.

The objective completion date for increasing emergency management staff was delayed to further examine business strategy and associated initiative needs. Further delay is expected, considering the hiring and onboarding processes.

### 2.1.4.3 Personnel Qualifications (WMP.1335)

Objective: Add one new state-of-the-art Tactical Mobile Command Trailer to the emergency fleet.

The objective completion date for adding a Tactical Mobile Command Trailer was adjusted due to vendor selection challenges and supply chain disruptions. Although vendor choices have been narrowed down, further delay is expected for required modifications.

### 2.1.4.4 Personnel Qualifications (WMP.1335)

Objective: Put two new state-of-the-art Incident Support Vehicles in service to support existing fleet in field incidents.

The objective completion date for the Incident Support Vehicles was adjusted due to vendor supply disruptions. Delivery and installation of radios and data link systems, including necessary modifications for both vehicles, has been delayed.

## 2.1.5 Community Outreach and Engagement

There were no changes to Community Outreach and Engagement objective completion dates.

## 2.1.6 Public Safety Power Shutoff

### 2.1.6.1 Risk Assessment Improvement Plan (WMP.1339)

Objective: Supplant Vegetation Risk Index (VRI) with a predictive model for the likelihood of vegetation-related failures.

In 2023 evaluation began on the transition of the current VRI to a predictive model. In collaboration with the University of California at San Diego (UCSD), a machine learning model was created that assessed the probability of vegetation-related outages given forecasted weather conditions. In addition, a vegetation model was created within the WiNGS-Ops suite of models that was designed to assess the probability of vegetation contact with assets.

Both models are currently being evaluated and potential consolidation into a unified model is being considered. Future enhancements for this consolidated model are also under review. While a definitive decision on replacement of the current VRI model has not been reached, ongoing development will continue as part of SDG&E's commitment to refine and advance the existing VRI model. Therefore, the objective completion date for supplanting the VRI was adjusted.

## 2.2 Targets and Expenditures

---

Energy Safety defines qualified target changes as a change in 10% or more for large volume work (equal to or greater than 100 units) or a change of 20% or more for small volume work (less than 100 units). Energy Safety defines qualified changes in expenditures as an increase or decrease of more than \$10 million or an increase or decrease that constitutes a greater than 20% change.<sup>13</sup> This section outlines changes in targets and expenditures that meet the OEIS threshold.

In order to provide a succinct narrative and avoid excessive repetition, this section was restructured from directions provided in the WMP Technical Guidelines. Targets and expenditures are grouped by initiative category as defined in Section 8 of the 2023-2025 Wildfire Mitigation Plan. Within each group, the initiative with a qualifying target and/or expenditure change is identified by its tracking ID and the change justification is provided. Table 6 includes initiatives with qualifying changes to targets and expenditures and Table 7 includes initiatives that have qualifying changes in expenditures only.

SDG&E notes that the California Public Utilities Commission (Commission or CPUC) is currently considering the Company's Test Year 2024 General Rate Case (GRC), and many of the initiatives described in the 2025 WMP Update are currently pending approval by the Commission. The expenditures reported in this 2025 WMP Update reflect the Proposed Settlement Agreement reached between SDG&E and Cal Advocates.<sup>14</sup> Upon a final decision in SDG&E's pending GRC, SDG&E may elect to submit a Change Order Request to Energy Safety to align financial expenditures with costs deemed just and reasonable by the Commission.

---

<sup>13</sup> 2025 Wildfire Mitigation Plan Update Guidelines, Section 2.1 and 2.3

<sup>14</sup> CPUC Docket A.22-05-016

**Table 6: Qualifying Changes in Targets and Expenditures (in Thousands)**

WMP	Initiative Name	2025 Original Target	2025 Updated Target	% Change*	2025 Original Capital Expenditures	2025 Updated Capital Expenditures	Dollar Change of 2025 Capital Expenditure	% Change of 2025 Capital Expenditure**	2025 Original O&M Expenditures	2025 Updated O&M Expenditures	Dollar Change of 2025 O&M Expenditure	% Change of 2025 O&M Expenditure**
WMP.455	Covered Conductors	40	60	50%	\$48,246	\$67,632	\$19,386	40%	\$592	\$3,090	\$2,498	422%
WMP.459	Expulsion fuse replacement	0	700	100%***	\$0	\$1,550	\$1,550	100%***	\$ -	\$ -	\$ -	n/a
WMP.462	Microgrids	0	2	100%***	\$0	\$14,127	\$14,127	100%***	\$1,788	\$1,445	-\$343	-19%
WMP.464	Hot Line Clamps	0	950	100%***	\$0	\$1,702	\$1,702	100%***	\$120	\$52	-\$68	-56%
WMP.468	Standby Power Programs	300	89	-70%	\$ -	\$ -	\$ -	n/a	\$10,590	\$5,539	-\$5,051	-48%
WMP.473	Strategic Undergrounding	150	125	-17%	\$356,654	\$358,877	\$2,223	1%	\$2,921	\$1,709	-\$1,212	-41%
WMP.475	Distribution OH Traditional Hardening	0.6	0	-100%	\$905	\$1,078	\$173	19%	\$48	\$963	\$915	1,906%
WMP.479	Transmission OH Detailed Inspections	1979	2479	25%	\$406	\$1,943	\$1,537	378%	\$108	\$38	-\$70	-65%
WMP.481	Distribution Infrared Inspections	9,532	300	-97%	\$ -	\$ -	\$ -	n/a	\$175	\$10	-\$165	-94%
WMP.482	Transmission Infrared Inspections	6179	7331	18%	\$ -	\$ -	\$ -	n/a	\$ -	\$ -	\$ -	n/a
WMP.483	Distribution Wood Pole Intrusive Inspections	0	344	100%***	\$1,460	\$1,462	\$2	0%	\$126	\$104	-\$22	-18%
WMP.489	Transmission OH Patrol Inspections	6337	7533	19%	\$ -	\$ -	\$ -	n/a	\$ -	\$ -	\$ -	n/a
WMP.491	QA/QC of Distribution Detailed Inspections	66	50%	n/a (see Section 5.12, ACI SDGE-23-13)	\$ -	\$ -	\$ -	n/a	\$ -	\$ -	\$ -	n/a
WMP.543	Transmission OH Hardening	10.2	4.64	-55%	\$ -	\$ -	\$ -	n/a	\$ -	\$ -	\$ -	n/a

WMP	Initiative Name	2025 Original Target	2025 Updated Target	% Change*	2025 Original Capital Expenditures	2025 Updated Capital Expenditures	Dollar Change of 2025 Capital Expenditure	% Change of 2025 Capital Expenditure**	2025 Original O&M Expenditures	2025 Updated O&M Expenditures	Dollar Change of 2025 O&M Expenditure	% Change of 2025 O&M Expenditure**
WMP.545	Transmission Overhead Hardening – Distribution Underbuild	<b>3.4</b>	<b>1.8</b>	<b>-62%</b>	<b>\$4,747</b>	<b>\$14,694</b>	<b>\$9,947</b>	<b>210%</b>	<b>\$0</b>	<b>\$4</b>	<b>\$4</b>	<b>100%***</b>
WMP.549	Distribution Communications Reliability Improvements	<b>90</b>	<b>42</b>	<b>-53%</b>	<b>\$67,964</b>	<b>\$43,213</b>	<b>-\$24,751</b>	<b>-36%</b>	\$879	\$999	\$120	14%
WMP.970	Air Quality Management Program	<b>6</b>	<b>0</b>	<b>-100%</b>	\$0	\$0	\$0	0%	<b>\$100</b>	<b>\$0</b>	<b>-\$100</b>	<b>-100%</b>
WMP.972	Avian Protection	<b>0</b>	<b>200</b>	<b>100%***</b>	\$1,512	\$1,512	\$0	0%	<b>\$120</b>	<b>\$10</b>	<b>-\$110</b>	<b>-91%</b>
WMP.1189	Strategic Pole Replacement Program	<b>200</b>	<b>291</b>	<b>46%</b>	\$6,701	\$6,948	\$247	4%	<b>\$506</b>	<b>\$4</b>	<b>-\$502</b>	<b>-99%</b>
WMP.1190	Transmission Wood Pole Intrusive Inspections	<b>141</b>	<b>114</b>	<b>-19%</b>	\$ –	\$ –	\$ –	n/a	\$ –	\$ –	\$ –	n/a
WMP.1193	QA/QC of Wood Pole Intrusive (Transmission & Distribution)	<b>14</b>	<b>40</b>	<b>186%</b>	\$ –	\$ –	\$ –	n/a	\$ –	\$ –	\$ –	n/a

\*Qualified Target changes are a change in 10% or more for large volume work (equal to or greater than 100 units) or a change of 20% or more for small volume work (less than 100 units) and are shown in bold font.

\*\*Qualified Expenditure changes are an increase or decrease of more than \$10 million or an increase or decrease that constitutes a greater than 20% change and are shown in bold font.

\*\*\*% change is shown as 100% for this initiative when the target or expenditures were updated from zero values.

“–” indicates no target, capital expenditures, or O&M expenditures were planned for this initiative.

**Table 7: Qualifying Changes in Expenditures only (in Thousands)**

WMP Initiative	Initiative Name	2025 Original Capital Expenditures	2025 Updated Capital Expenditures	Dollar Change of 2025 Capital Expenditure	% Change of 2025 Capital Expenditure*	2025 Original O&M Expenditures	2025 Updated O&M Expenditures	Dollar Change of 2025 O&M Expenditure	% Change of 2025 O&M Expenditure*
WMP.442	Risk Assessment and Mapping	\$ –	\$ –	\$ –	n/a	\$4,017	\$3,436	-\$581	-14%
WMP.447	Weather Station Network and NDVI Cameras	<b>\$437</b>	<b>\$0</b>	<b>-\$437</b>	<b>-100%</b>	\$ –	\$ –	\$ –	n/a

WMP Initiative	Initiative Name	2025 Original Capital Expenditures	2025 Updated Capital Expenditures	Dollar Change of 2025 Capital Expenditure	% Change of 2025 Capital Expenditure*	2025 Original O&M Expenditures	2025 Updated O&M Expenditures	Dollar Change of 2025 O&M Expenditure	% Change of 2025 O&M Expenditure*
WMP.449	Wireless Fault Indicators	\$299	\$0	-\$299	-100%	\$0	\$0	\$0	0%
WMP.450	Fire Potential Index (FPI)	\$2,783	\$1,477	-\$1,306	-47%	\$2,413	\$4,366	\$1,953	81%
WMP.463	Advanced Protection	\$8,194	\$3,383	-\$4,811	-59%	\$117	\$207	\$90	77%
WMP.466	Generator Grant Programs	\$ -	\$ -	\$ -	n/a	\$7,550	\$3,233	-\$4,317	-57%
WMP.467	Generator Assistance Programs	\$ -	\$ -	\$ -	n/a	\$1,828	\$501	-\$1,327	-73%
WMP.478	Distribution Overhead Detailed Inspections	\$7,186	\$9,563	\$2,377	33%	\$327	\$824	\$497	152%
WMP.484	LiDAR Inspections of Distribution Electric Lines and Equipment	\$ -	\$ -	\$ -	n/a	\$1,500	\$0	-\$1,500	-100%
WMP.494	Detailed Vegetation Inspections	\$ -	\$ -	\$ -	n/a	\$47,540	\$61,887	\$14,347	30%
WMP.519	WMP Data Platform	\$7,833	\$15,331	\$7,498	96%	\$1,650	\$1,688	\$38	2%
WMP.523	Allocation Methodology Development and Application	\$7,297	\$1,106	-\$6,191	-85%	\$7,988	\$5,524	-\$2,464	-31%
WM.527	Public Outreach and Education Awareness	\$1,697	\$0	-\$1,697	-100%	\$4,847	\$4,004	-\$843	-17%
WMP.551	HFTD Tier 3 Distribution Pole Inspections	\$2,361	\$0	-\$2,361	-100%	\$313	\$0	-\$313	-100%
WMP.552	Drone Assessments	\$20,670	\$54,937	\$34,267	166%	\$12,656	\$31,490	\$18,834	149%
WMP.557	Aviation Firefighting Program	\$0	\$689	\$689	100%**	\$11,539	\$8,366	-\$3,173	-28%
WMP.563	Public Emergency Communication Strategy	\$0	\$7,757	\$7,757	100%**	\$6,381	\$5,219	-\$1,162	-18%
WMP.1008	Emergency Preparedness	\$1,729	\$315	-\$1,414	-82%	\$16,566	\$16,148	-\$418	-3%
WMP.1016	CNF Distribution Underground	\$422	\$0	-\$422	-100%	\$138	\$0	-\$138	-100%
WMP.1017	CNF Distribution Overhead	\$545	\$648	\$103	19%	\$0	\$155	\$155	100%**
WMP.1195	Early Fault Detection	\$4,070	\$3,410	-\$660	-16%	\$67	\$4	-\$63	-94%

\*Qualified Expenditure changes are an increase or decrease of more than \$10 million or an increase or decrease that constitutes a greater than 20% change and are shown in bold font.

\*\*% change is shown as 100% for this initiative when the expenditures were updated from zero values.

“-“ indicates no capital expenditures or O&M expenditures were planned for this initiative.

## 2.2.1 Grid Design, Operations, and Maintenance

### 2.2.1.1 Wireless Fault Indicators (WMP.449)

#### 2.2.1.1.1 Targets

There was no change in 2025 target for WFIs. The target remained at zero.

#### 2.2.1.1.2 Projected Expenditures

The 2025 projected capital expenditures for WFIs were decreased by 100% to zero.

#### 2.2.1.1.3 Change Justification

The Wireless Fault Indicator initiative was paused due to manufacturer upgrades to the currently used WFIs. Upgraded WFIs require different communication specifications not currently employed, therefore, the feasibility of implementing this type of equipment is being evaluated. In addition, other types of WFIs from various manufacturers will be evaluated to determine the best approach. In the interim, SCADA devices and existing WFIs will be utilized to provide situational awareness and guide first responders to the likely location of a fault. This change is not expected to impact wildfire risk reduction within the 2023-2025 WMP cycle.

### 2.2.1.2 Covered Conductor (WMP.455)

#### 2.2.1.2.1 Targets

The 2025 target for Covered Conductor was increased by 50%.

#### 2.2.1.2.2 Projected Expenditures

The 2025 projected capital expenditures for Covered Conductor were increased by 40%. The 2025 projected Operations & Maintenance (O&M) expenditures for Covered Conductor were increased by 422%.

#### 2.2.1.2.3 Change Justification

The 2025 target and projected capital and O&M expenditures were increased due to a shift in work from 2024 to 2025. The 2024 target was reduced by 33% due to design delays as described in the 2023 Change Order Request.<sup>15</sup> The total forecasted mileage for the remainder of the 2023-2025 WMP cycle remains unchanged.

### 2.2.1.3 Expulsion Fuse Replacement (WMP.459)

#### 2.2.1.3.1 Targets

The 2025 target for Expulsion Fuse Replacement was increased by 100%.

#### 2.2.1.3.2 Projected Expenditures

The 2025 projected capital expenditures for Expulsion Fuse Replacement increased by 100%.

---

<sup>15</sup> San Diego Gas & Electric 2023 Change Order Report; [https://www.sdge.com/sites/default/files/regulatory/2023-12-19\\_SDGE\\_2023\\_Change%20Order%20Report\\_R1.pdf](https://www.sdge.com/sites/default/files/regulatory/2023-12-19_SDGE_2023_Change%20Order%20Report_R1.pdf)

#### 2.2.1.3.3 Change Justification

According to a recent assessment based on a data extract provided by geographic information system (GIS), roughly 1,000 fuses have not yet been replaced with CAL FIRE-approved fuses in the HFTD. Therefore, the target was increased to ensure all expulsion fuses in the HFTD are replaced with CAL FIRE-approved fuses.

#### 2.2.1.4 Microgrids (WMP.462)

##### 2.2.1.4.1 Targets

The 2025 target for Microgrids was increased by 100%.

##### 2.2.1.4.2 Projected Expenditures

The 2025 projected capital expenditures for Microgrids were increased by 100%.

##### 2.2.1.4.3 Change Justification

The 2025 target was increased by 100% due to a shift in work from 2024 to 2025. This change is due to delays in acquiring appropriate land rights, ongoing supply chain issues that resulted in increases to material costs (i.e., battery, solar photovoltaic panels), and increases in labor costs. Completion of the permanent renewable components at the Shelter Valley and Butterfield Ranch microgrids are expected in 2025 and construction of two Remote Grid Standalone Power Systems is expected to begin in 2025. Even though both the Shelter Valley and Butterfield Ranch microgrids are capable of serving customers using fossil fuels, SDG&E does not consider the projects fully complete until the renewable configuration/ components are in place.

The total forecasted targets for microgrids for the remainder of the 2023-2025 WMP cycle remain unchanged.

#### 2.2.1.5 Advanced Protection (WMP.463)

##### 2.2.1.5.1 Targets

There was no change in the 2025 target for Advanced Protection.

##### 2.2.1.5.2 Projected Expenditures

The 2025 projected capital expenditures for Advanced Protection were decreased by 59%. The 2025 projected O&M expenditures for the Advanced Protection were increased by 77%.

##### 2.2.1.5.3 Change Justification

The 2025 projected capital expenditures were decreased due to future projects having a smaller scope. The 2025 projected O&M expenditures were increased due to adjustments made to align 2025 expenditures with historical O&M spend data.

#### 2.2.1.6 Hotline Clamp Replacement Program (WMP.464)

##### 2.2.1.6.1 Targets

The 2025 target for HLC replacement was increased by 100%.



#### 2.2.1.6.2 Projected Expenditures

The 2025 projected capital expenditures for HLC replacement were increased by 100%. The projected O&M expenditures for HLC replacement were decreased by 56%.

#### 2.2.1.6.3 Change Justification

Changes in the HLC replacement target and related projected expenditures resulted from fielding assessments performed in tandem with Lightning Arrestor Removal and Replacement (WMP.550), Avian Protection (WMP.972), and Expulsion Fuse Replacement (WMP.459) fielding. Fielding assessments performed in 2023 resulted in a significant number of structures in the HFTD and Wildland Urban Interface (WUI) that require HLC replacement, therefore, the target and projected capital and O&M expenditures were adjusted.

### 2.2.1.7 Generator Grant Program (WMP.466)

#### 2.2.1.7.1 Targets

There was no 2025 target set for the Generator Grant Program (GGP).

#### 2.2.1.7.2 Projected Expenditures

The 2025 projected O&M expenditures for the GGP were decreased by 57%.

#### 2.2.1.7.3 Change Justification

As the GGP matures and the most at-risk qualifying customers receive the benefits, the remaining pool of eligible customers decreases yearly. In addition, demand among qualified customers is tied to anticipation of a PSPS de-energization, and a recent decrease in PSPS events has likely resulted in a decrease in perceived resiliency needs among qualifying customers. The 2025 projected O&M expenditures for the GGP were therefore decreased to align the initiative with updated resiliency needs of qualifying customers based on updated PSPS de-energization trends.

### 2.2.1.8 Generator Assistance Program (WMP.467)

#### 2.2.1.8.1 Targets

There was no 2025 target set for the Generator Assistance Program (GAP).

#### 2.2.1.8.2 Projected Expenditures

The 2025 projected O&M expenditures for the GAP were decreased by 73%.

#### 2.2.1.8.3 Change Justification

The GAP is developed based on the expectation that customers will participate in anticipation of a PSPS de-energization due to high winds, wildfire risk, or other weather emergencies. When perceived or actual likelihood of a PSPS de-energization is reduced, customer participation decreases. The 2025 projected O&M expenditures for the GGP were therefore decreased to align the initiative with updated resiliency needs of qualifying customers based on updated PSPS de-energization trends.

### **2.2.1.9 Standby Power Programs (WMP.468)**

#### **2.2.1.9.1 Targets**

The 2025 target for Standby Power Programs was decreased by 70%.

#### **2.2.1.9.2 Projected Expenditures**

The 2025 projected O&M expenditures for Standby Power Programs were decreased by 48%.

#### **2.2.1.9.3 Change Justification**

In 2024, the Standby Power Programs will reach their intended goal, including mitigations of over 1,200 residential customers and 19 commercial sites, and provide valuable strategic and operational lessons learned. In 2025, the programs will build on 2024 efforts to explore and evaluate additional mitigation approaches, continuing to support customer resilience while focusing on climate adaptation outcomes such as renewable backup power options. Program adjustments will be made to support these design enhancements and the 2025 target was adjusted accordingly.

### **2.2.1.10 Strategic Undergrounding (WMP.473)**

#### **2.2.1.10.1 Targets**

The 2025 target for Strategic Undergrounding was decreased by 17%.

#### **2.2.1.10.2 Projected Expenditures**

The 2025 projected O&M expenditures for Strategic Undergrounding were decreased by 41%.

#### **2.2.1.10.3 Change Justification**

The 2025 target was reduced from 150 miles to 125 miles to match the forecasted capital costs and associated miles of undergrounding of electric lines to align with the 2024 Test Year GRC Settlement Agreement with the California Public Advocates Office.<sup>16</sup> The 2025 projected O&M expenditures for Strategic Undergrounding were decreased due to adjustments made to align 2025 expenditures with historical spend data.

### **2.2.1.11 Distribution Overhead System Hardening (WMP.475)**

#### **2.2.1.11.1 Targets**

The 2025 target for Distribution Overhead System Hardening was decreased by 100%.

#### **2.2.1.11.2 Projected Expenditures**

The 2025 projected O&M expenditures for Distribution Overhead System Hardening were increased by 1,906%.

---

<sup>16</sup> Joint Motion of Southern California Gas Company (U 904-G), San Diego Gas & Electric Company (U 902-M), and the Public Advocates Office for Adoption of Settlement Agreements Resolving Various Issues in the 2024 General Rate Case; [https://www.socalgas.com/sites/default/files/Joint\\_Motion\\_for\\_Approval\\_of\\_Settlement\\_4-16-20.pdf](https://www.socalgas.com/sites/default/files/Joint_Motion_for_Approval_of_Settlement_4-16-20.pdf)

### 2.2.1.11.3 Change Justification

Distribution overhead system hardening work will be completed by the end of 2024. Additional work is not planned due to the transition to the covered conductor initiative (WMP.455) (see Section 2.2.1.2 for updates on the covered conductor initiative). Therefore, the 2025 target was reduced to zero.

The 2025 projected O&M expenditures for Distribution Overhead System Hardening were increased due to historical O&M cost trend indicators.

### 2.2.1.12 Distribution Overhead Detailed Inspections (WMP.478)

#### 2.2.1.12.1 Targets

The 2025 target for Distribution Overhead Detailed Inspections was not changed.

#### 2.2.1.12.2 Projected Expenditures

The 2025 projected capital expenditures for Distribution Overhead Detailed Inspections were increased by 33%. The 2025 projected O&M expenditures for Distribution Overhead Detailed Inspections were increased by 152%.

#### 2.2.1.12.3 Change Justification

The projected capital and O&M expenditures were increased due to expected additional inspections and resulting corrective work. These additional inspections did not meet the criteria for significant target change.

### 2.2.1.13 Transmission Overhead Detailed Inspections (WMP.479)

#### 2.2.1.13.1 Targets

The 2025 target for Transmission Overhead Detailed Inspections was increased by 25%.

#### 2.2.1.13.2 Projected Expenditures

The 2025 projected capital expenditures for Transmission Overhead Detailed Inspections were increased by 378%. The 2025 projected O&M expenditures for Transmission Overhead Detailed Inspections were decreased by 65%.

#### 2.2.1.13.3 Change Justification

The target and projected capital expenditures were increased due to incorporating the existing practice of WUI inspections and repair work into the WMP reporting. The 2025 projected O&M expenditures decreased due to a lower expected finding rate.

### 2.2.1.14 Distribution Infrared Inspections (WMP.481)

#### 2.2.1.14.1 Targets

The 2025 target for Distribution Infrared Inspections was decreased by 97%.

#### 2.2.1.14.2 Projected Expenditures

The 2025 projected O&M expenditures for Distribution Infrared Inspections were decreased by 94%.

### 2.2.1.14.3 Change Justification

In 2024, the selection of structures for distribution infrared inspections will evolve into a risk-informed strategy. Prior to 2024, structures were selected based on the recommendations of subject matter experts with knowledge and experience of the service territory based on their perceived “risk”. However, this method of inspection yielded a low findings rate of 0.2%. To promote efficiency, the initiative is therefore being optimized to target specific areas in the WUI that demonstrate higher loads during peak season (summer). In addition, a limited number of infrared inspections will be performed on covered conductor circuit segments to determine whether thermography is useful in identifying potential damage conditions to the covered conductor.

The 2025 projected O&M expenditures were decreased due to the decreased volume of work planned for 2025.

### 2.2.1.15 Transmission Infrared Inspections (WMP.482)

#### 2.2.1.15.1 Targets

The 2025 target for Transmission Infrared Inspections was increased by 18%.

#### 2.2.1.15.2 Projected Expenditures

Expenditures for this initiative are Federal Energy Regulatory Commission (FERC)-funded and are not reported within the WMP.

#### 2.2.1.15.3 Change Justification

The target was increased due to incorporating the existing practice regarding WUI inspections and repair work into the WMP reporting.

### 2.2.1.16 Distribution Wood Pole Intrusive Inspections (WMP.483)

#### 2.2.1.16.1 Targets

The 2025 target for Distribution Wood Pole Intrusive Inspections was increased by 100%.

#### 2.2.1.16.2 Projected Expenditures

There were no significant changes to the 2025 projected capital or O&M expenditures for Distribution Wood Pole Intrusive Inspections.

#### 2.2.1.16.3 Change Justification

In 2025, the Distribution Wood Pole Intrusive Inspections will focus on the coastal areas. Initially, it was anticipated there would be no poles due for inspection in Tier 2 of the HFTD in the coastal areas. Upon assessing the updated data, a minimal number of wood poles were identified that are due for inspection, and the target was updated accordingly.

### 2.2.1.17 LiDAR Inspections of Distribution Electric Lines and Equipment (WMP.484)

#### 2.2.1.17.1 Targets

There was no 2025 target for Light detection and ranging (LiDAR) Inspections of Distribution Electric Lines and Equipment.

#### 2.2.1.17.2 Projected Expenditures

The 2025 projected O&M expenditures for the LiDAR Inspections of Distribution Electric Lines and Equipment were decreased by 100%.

#### 2.2.1.17.3 Change Justification

The 2025 projected O&M expenditures were decreased as the initiative was completed in 2022 and is not anticipated to be repeated in 2025.

### 2.2.1.18 Transmission Overhead Patrol Inspections (WMP.489)

#### 2.2.1.18.1 Targets

The 2025 target for Transmission Overhead Patrol Inspections was increased by 19%.

#### 2.2.1.18.2 Projected Expenditures

Expenditures for this initiative are FERC-funded and are not reported within the WMP.

#### Change Justification

The target was increased due to incorporating WUI inspections and repair work into the WMP reporting.

### 2.2.1.19 QA/QC of Distribution Detailed Inspections (WMP.491)

#### 2.2.1.19.1 Targets

The 2025 target for Quality Assessment/Quality Control (QA/QC) of distribution detailed inspections was changed from an inspection count to a percentage of issues identified during inspections, therefore a target percent change cannot be calculated.

#### 2.2.1.19.2 Projected Expenditures

Expenditures for QA/QC of distribution detailed inspections are budgeted as part of the overall distribution detailed inspection initiative (WMP.478).

#### 2.2.1.19.3 Change Justification

QA/QC for distribution detailed inspections changed in response to ACI SDGE-23-13, which resulted in a significant scope and target change. In 2025, QA/QC will be performed on 50% of findings identified during inspection within 1 month of the inspection. See ACI SDGE-23-13 (Section 5.12) for details on the enhancement of QA/QC for distribution detailed inspections.

### 2.2.1.20 Transmission Overhead Hardening (WMP.543)

#### 2.2.1.20.1 Targets

The 2025 target for transmission overhead hardening was decreased by 55%.

#### 2.2.1.20.2 Projected Expenditures

Expenditures for this initiative are FERC-funded and are not reported within the WMP.

### 2.2.1.20.3 Change Justification

The 2025 target in Tier 2 of the HFTD was reduced due to an expected shift in work to 2024. Overall, the forecasted mileage for the remainder of the 2023-2025 WMP cycle is unchanged.

### 2.2.1.21 Transmission Overhead Hardening – Distribution Underbuild (WMP.545)

#### 2.2.1.21.1 Targets

The 2025 target for transmission overhead hardening – distribution underbuild was decreased by 62%.

#### 2.2.1.21.2 Projected Expenditures

The 2025 projected capital expenditures for transmission overhead hardening – distribution underbuild were increased by 210%. The 2025 projected O&M expenditures for transmission overhead hardening – distribution underbuild were increased by 100%.

#### 2.2.1.21.3 Change Justification

The 2025 target was reduced as some work shifted from 2025 to 2024. The forecasted mileage for the remainder of the 2023-2025 WMP cycle is unchanged. The 2025 projected capital expenditures for transmission overhead hardening – distribution underbuild were increased due to additional projects beginning in 2025 that will be completed in the 2026-2028 WMP cycle. The 2025 projected O&M expenditures were increased due to adjustments made to align 2025 expenditures with historical O&M spend data.

### 2.2.1.22 Distribution Communications Reliability Improvements (WMP.549)

#### 2.2.1.22.1 Targets

The 2025 target for Distribution Communications Reliability Improvements (DCRI) was decreased by 53%.

#### 2.2.1.22.2 Projected Expenditures

The 2025 projected capital expenditures for DCRI were decreased by 36%.

#### 2.2.1.22.3 Change Justification

Most sites planned for base station installation have engineered steel foundation poles that will have telecommunication antennas at the top of the pole and electric (12 kV and below) attachments in the middle of the pole. Poles are currently undergoing standardization, and development of pole specifications, including workspace, operational, and manufacturing requirements, has taken longer than expected. To complete the pole standardization, three pilot sites were selected and pole orders were placed at the end of 2023. In 2024, construction of these three pilot sites and standardization of pole designs is expected to be completed, which will accelerate the initiative in 2025 and beyond. In addition, process improvements with substation and transmission facility engineering and operations groups are being developed to ensure proper design and construction.

Workplan modifications will delay improvements expected from the SDG&E-owned private LTE network backbone that supports some Advanced Protection initiatives including Falling Conductor Protection (FCP) and Early Fault Detection (EFD). FCP and EFD work will continue to be deployed in the interim and

will be enhanced once the LTE backbone is completed. This change is not expected to impact expected wildfire risk reduction within the 2023-2025 WMP cycle.

### **2.2.1.23 HFTD Tier 3 Distribution Pole Inspections (WMP.551)**

#### **2.2.1.23.1 Targets**

There was no 2025 target for HFTD Tier 3 Distribution Pole Inspections.

#### **2.2.1.23.2 Projected Expenditures**

The 2025 projected capital expenditures for HFTD Tier 3 Distribution Pole Inspections were decreased by 100%. The 2025 projected O&M expenditures for HFTD Tier 3 Distribution Pole Inspections were decreased by 100%.

#### **2.2.1.23.3 Change Justification**

The projected capital and O&M expenditures were decreased due to discontinuance of this program in 2022.

### **2.2.1.24 Drone Assessments (WMP.552)**

#### **2.2.1.24.1 Targets**

The 2025 target for Drone Assessments did not change.

#### **2.2.1.24.2 Projected Expenditures**

The 2025 projected capital expenditures for Drone Assessments were increased by 166%, and the 2025 projected O&M expenditures were increased by 149%.

#### **2.2.1.24.3 Change Justification**

The 2025 projected capital expenditures for Drone Assessments were increased due to higher number of findings requiring repair from Tier 2 drone inspections and risk-informed drone inspections than originally anticipated.

### **2.2.1.25 Avian Protection (WMP.972)**

#### **2.2.1.25.1 Targets**

The 2025 target for Avian Protection was increased by 100%.

#### **2.2.1.25.2 Projected Expenditures**

The 2025 projected O&M expenditures were decreased by 91%.

#### **2.2.1.25.3 Change Justification**

Fielding for Avian Protection is done in tandem with Lightning Arrestor Removal and Replacement (WMP.550), HLC replacement (WMP.464), and Expulsion Fuse Replacement (WMP.459) fielding. In 2023, fielding showed a significant number of structures in the HFTD and WUI that require avian retrofitting, and the 2025 target was adjusted accordingly. By combining Avian Protection fielding with other mitigation initiatives, some O&M cost efficiencies are expected and 2025 projected O&M expenditures were adjusted accordingly.

### **2.2.1.26 Cleveland National Forest Overhead (Distribution Underground) (WMP.1016)**

#### **2.2.1.26.1 Targets**

There was no 2025 target for Cleveland National Forest Overhead (Distribution Underground).

#### **2.2.1.26.2 Projected Expenditures**

The 2025 projected capital expenditures for Cleveland National Forest Overhead (Distribution Underground) were decreased by 100%. The 2025 projected O&M expenditures for Cleveland National Forest Overhead (Distribution Underground) were decreased by 100%.

#### **2.2.1.26.3 Change Justification**

The Cleveland National Forest Overhead (Distribution Underground) is complete, and as such, related expenditures were adjusted.

### **2.2.1.27 Cleveland National Forest Overhead (Distribution Overhead) (WMP.1017)**

#### **2.2.1.27.1 Targets**

There was no 2025 target for Cleveland National Forest Overhead (Distribution Overhead).

#### **2.2.1.27.2 Projected Expenditures**

The 2025 projected O&M expenditures for Cleveland National Forest Overhead (Distribution Overhead) were increased by 100%.

#### **2.2.1.27.3 Change Justification**

The Cleveland National Forest Overhead (Distribution Overhead) is complete, however there are project close-out activities that remain to be completed. Due to re-alignment of project close-out scope issues and/or delays, related expenditures were adjusted and are projected to extend into 2029.

### **2.2.1.28 Strategic Pole Replacement Program (WMP.1189)**

#### **2.2.1.28.1 Targets**

The 2025 target for the Strategic Pole Replacement Program was increased by 46%.

#### **2.2.1.28.2 Projected Expenditures**

The 2025 projected O&M expenditures for the Strategic Pole Replacement Program were decreased by 99%.

#### **2.2.1.28.3 Change Justification**

Through the Corrective Maintenance Program (CMP) and grid hardening initiatives, an increase in the scope, and therefore target, of this initiative was identified. In addition to replacing cellon-treated wood poles, this initiative will also target poles that require pole loading remediation.

The 2025 projected O&M expenditures were decreased as costs are included in the CMP.



### **2.2.1.29 Transmission Wood Pole Intrusive Inspections (WMP.1190)**

#### **2.2.1.29.1 Targets**

The 2025 target for Transmission Wood Pole Intrusive Inspections was decreased by 19%.

#### **2.2.1.29.2 Projected Expenditures**

Expenditures for this initiative are FERC-funded and are not reported within the WMP.

#### **2.2.1.29.3 Change Justification**

The 2025 target was reduced due to routine operational changes in the electric system. Some structures in the initial forecast are now steel structures that do not require an intrusive inspection, some were removed from service, and some were intrusively inspected in 2022 or 2023 and do not require an intrusive inspection in 2025. Also, beginning in 2025, the existing practice of performing inspections in the WUI will be incorporated into the WMP reporting.

### **2.2.1.30 QA/QC of Wood Pole Intrusive (Transmission and Distribution) (WMP.1193)**

#### **2.2.1.30.1 Targets**

The 2025 target for QA/QC of Wood Pole Intrusive (Transmission and Distribution) was increased by 186%.

#### **2.2.1.30.2 Projected Expenditures**

There were no significant changes to 2025 projected capital or O&M expenditures.

#### **2.2.1.30.3 Change Justification**

The target for QA/QC of wood pole intrusive inspections is derived from 10% of completed inspections. The 2025 target increase is due to the overall target increase for transmission and distribution wood pole intrusive inspections (WMP.1190 and WMP.483) described in Sections 2.2.1.9 and 2.2.1..

### **2.2.1.31 Early Fault Detection (WMP.1195)**

#### **2.2.1.31.1 Targets**

There was no change in the 2025 target for EFD.

#### **2.2.1.31.2 Projected Expenditures**

The 2025 projected O&M expenditures for the EFD were decreased by 94%.

#### **2.2.1.31.3 Change Justification**

The 2025 projected O&M expenditures were decreased as fewer EFD nodes have been installed in the field, resulting in lower maintenance costs.

## **2.2.2 Vegetation Management and Inspection**

### **2.2.2.1 Detailed Vegetation Inspections (WMP.494)**

#### **2.2.2.1.1 Targets**

There was no change in the 2025 target for Detailed Vegetation Inspections.

#### 2.2.2.1.2 Projected Expenditures

The 2025 projected O&M expenditures for Detailed Vegetation Inspections were increased by 30%.

#### 2.2.2.1.3 Change Justification

The 2025 projected O&M expenditures were increased due to unforeseen increases in contractor rates associated with negotiated service agreements in mid-2023.

### 2.2.3 Situational Awareness and Forecasting

#### 2.2.3.1 Weather Station Network and NDVI Cameras (WMP.447)

##### 2.2.3.1.1 Targets

There was no change in the 2025 target for Weather Station Network and NDVI Cameras.

##### 2.2.3.1.2 Projected Expenditures

The 2025 projected capital expenditures for the Weather Station Network and NDVI decreased by 100%.

##### 2.2.3.1.3 Change Justification

Due to weather station sensor saturation in the service territory, additional weather stations will not be built in 2024 or 2025, see Section 4.2 Discontinuance of a Program. A new initiative, Weather Station Maintenance and Calibration (WMP.1430) has been created to maintain the weather stations. See Section 4.1.1 (New Programs) and Section 5.17 (ACI SDGE-23-18) for additional information.

#### 2.2.3.2 Fire Potential Index (WMP.450)

##### 2.2.3.2.1 Targets

There is no target associated with this initiative.

##### 2.2.3.2.2 Projected Expenditures

The 2025 projected capital expenditures for the Fire Potential Index (FPI) decreased by 47%. The 2025 projected O&M expenditures for FPI were increased by 81%.

##### 2.2.3.2.3 Change Justification

FPI projected capital expenditures were decreased due to a change in accounting treatment for the software data subscriptions. Fire behavior modeling software can no longer be capitalized as the costs have almost completely transitioned to data subscriptions. See Section 5.17 (ACI SDGE-23-18) for additional information.

#### 2.2.3.3 Air Quality Management Program (WMP.970)

##### 2.2.3.3.1 Targets

The 2025 target for the Air Quality Management Program was decreased by 100%.

##### 2.2.3.3.2 Projected Expenditures

The 2025 projected O&M expenditures decreased by 100%.

#### 2.2.3.3.3 Change Justification

The Air Quality Management Program installed 15 particulate sensors between 2022 and 2023. The last remaining particulate sensor was installed by the end of 2023. Eighteen total sensors have been procured, one of which is used as a master unit for calibration and as an additional spare. Once installed, the 16 sensors will completely cover the HFTD and further installations would not provide additional benefit. Therefore, the 2025 target was reduced to zero and the program was discontinued (see Section 4.2 Discontinuance of a Program).

A new initiative, Air Quality Station Maintenance (WMP.1431) has been created to maintain and upgrade sensors as necessary. See Section 4.1.2 (New Programs) and Section 5.17 (ACI SDGE-23-18) for additional information.

### 2.2.4 Emergency Preparedness

#### 2.2.4.1 Aviation Firefighting Program (WMP.557)

##### 2.2.4.1.1 Targets

There is no 2025 target for the Aviation Firefighting Program.

##### 2.2.4.1.2 Projected Expenditures

The 2025 projected capital expenditures were increased by 100%. The 2025 projected O&M expenditures for the Aviation Firefighting Program were decreased by 28%.

##### 2.2.4.1.3 Change Justification

The 2025 projected capital expenditures were increased due to the need to purchase a spare engine for the Sikorsky S-70 Firehawk helicopter. The cost for the engine is being split between 2024 and 2025. The 2025 projected O&M expenditures were decreased due to recent contract negotiations lowering overall costs.

#### 2.2.4.2 Public Emergency Communication Strategy (WMP.563)

##### 2.2.4.2.1 Targets

There is no 2025 target for public emergency communication strategy.

##### 2.2.4.2.2 Projected Expenditures

The 2025 projected capital expenditures for public emergency communication strategy were increased by 100%.

##### 2.2.4.2.3 Change Justification

The 2025 capital expenditures were increased due to an increase in scope of the Public Safety Partner Portal (PSPP). The application was previously specific to PSPS protocols but has been expanded to include all hazards communications, which requires various enhancements.

#### 2.2.4.3 Emergency Preparedness (WMP.1008)

##### 2.2.4.3.1 Targets

There is no 2025 target for Emergency Preparedness.

#### 2.2.4.3.2 Projected Expenditures

The 2025 projected capital expenditures for Emergency Preparedness were decreased by 82%.

#### 2.2.4.3.3 Change Justification

The 2025 capital expenditures were decreased due to retirement of the Noggin program within Emergency Management in 2022 and the consideration of other technology solutions.

### 2.2.5 Community Outreach and Engagement

#### 2.2.5.1 Public Outreach and Education Awareness (WMP.527)

##### 2.2.5.1.1 Targets

There is no 2025 target for Public Outreach and Education Awareness.

##### 2.2.5.1.2 Projected Expenditures

The 2025 projected capital expenditures for Public Outreach and Education Awareness were decreased by 100%. The 2025 projected O&M expenditures for Public Outreach and Education Awareness were decreased by 17%.

##### 2.2.5.1.3 Change Justification

The 2025 capital and O&M expenditures were decreased due to a shift in expenditures from Public Outreach and Education Awareness (WMP.527) to Public Emergency Communication Strategy (WMP.563) (see Section 2.2.4.2).

### 2.2.6 Public Safety Power Shutoff

There were no significant target or expenditure changes to public safety power shutoff initiatives.

### 2.2.7 Mitigation Strategy Development

#### 2.2.7.1 Risk Assessment and Mapping (WMP.442)

##### 2.2.7.1.1 Targets

There is no 2025 target for Risk Assessment and Mapping.

##### 2.2.7.1.2 Projected Expenditures

The 2025 projected O&M expenditures for Risk Assessment and Mapping were increased by 100%.

##### 2.2.7.1.3 Change Justification

The 2025 projected capital expenditures were shifted to O&M expenditures. O&M expenditures were increased due to additional labor and external consulting services for addressing the evolving risk modeling needs and analysis of mitigation effectiveness.

#### 2.2.7.2 WMP Data Platform (WMP.519)

##### 2.2.7.2.1 Targets

There is no 2025 target for the WMP Data Platform.

#### 2.2.7.2.2 Projected Expenditures

The 2025 projected O&M expenditures for WMP Data Platform were increased by 96%.

#### 2.2.7.2.3 Change Justification

The 2025 projected O&M expenditures were increased due to additional work scope and project management for the WiNGS Visualization Platform.

### **2.2.7.3 Allocation Methodology Development and Application (WMP.523)**

#### 2.2.7.3.1 Targets

There is no 2025 target for Allocation Methodology Development and Application.

#### 2.2.7.3.2 Projected Expenditures

The 2025 projected capital expenditures for Allocation Methodology Development decreased by 85%. The 2025 projected O&M expenditures for Allocation Methodology Development and Application were decreased by 31%.

#### 2.2.7.3.3 Change Justification

The 2025 projected O&M expenditures were decreased to align with 2023 actual expenditures. Plans to add additional headcount to manage PSPS protocols have been placed on hold as PSPS de-energizations and reporting have been effectively managed with the current personnel.

### 3 Quarterly Inspection Targets for 2025

Table 8 lists quarterly targets for 2025 asset and vegetation inspection. If 2025 end-of-year targets were adjusted from what was reported in the 2023-2025 Wildfire Mitigation Plan, a change justification is provided in Section 2.2.

**Table 8: Asset Inspections and Vegetation Management Targets for 2025**

Initiative Activity	Tracking ID	Target End of Q2 2025 & Unit	Target End of Q3 2025 & Unit	End of Year Target 2025 & Unit	% Risk Impact 2025
Distribution Overhead Detailed Inspections	WMP.478	7,294	10,940	13,275	1.94%
Transmission Overhead Detailed Inspections	WMP.479	1,239	1,899	2,479	1.03%
Distribution Infrared Inspections	WMP.481	150	300	300	n/a
Transmission Infrared Inspections	WMP.482	0	0	7,331	0.18%
Distribution Wood Pole Intrusive Inspections	WMP.483	0	344	344	0.03%
Transmission Wood Pole Intrusive Inspections	WMP.1190	50	75	114	n/a
Drone Assessments	WMP.552	4,500	9,000	13,500	15.50%
Distribution Overhead Patrol Inspections	WMP.488	70,756	83,236	86,535	4.37%
Transmission Overhead Patrol Inspections	WMP.489	3,766	5,650	7,533	0.03%
Transmission 69kV Tier 3 Visual Inspections	WMP.555	0	1,632	1,632	0.02%
Substation Patrol inspections	WMP.492	189	277	384	n/a
QA/QC of Transmission Inspections	WMP.1191	100.00%	100.00%	100.00%	n/a
QA/QC of Distribution Detailed Inspections	WMP.491	50.00%	50.00%	50.00%	n/a
QA/QC of Distribution Drone Assessments	WMP.1192	4,500	9,000	13,500	n/a
QA/QC of Wood Pole Intrusive (Transmission & Distribution)	WMP.1193	40	40	40	n/a
QA/QC of Substation Inspections	WMP.1194	9	9	18	n/a
Vegetation Management Detailed Inspections	WMP.494	241,800	374,200	485,400	24.85%

Initiative Activity	Tracking ID	Target End of Q2 2025 & Unit	Target End of Q3 2025 & Unit	End of Year Target 2025 & Unit	% Risk Impact 2025
Vegetation Management Off-Cycle Patrol	WMP.508	9	106	106	n/a
Vegetation Management Fuels management	WMP.497	100	200	500	0.63%
Vegetation Management Pole Clearing (Brushing)	WMP.512	25,150	27,890	33,010	2.84%
Vegetation Management Clearance	WMP.501	5,710	8,600	11,200	0.10%
Vegetation Management QA/QC Vegetation Management	WMP.505	15.00%	15.00%	15.00%	n/a

## 4 New or Discontinued Programs

---

### 4.1 New Programs

---

#### 4.1.1 Weather Station Maintenance and Calibration (WMP.1430)

The Weather Station Network and NDVI Cameras (WMP.447) is evolving into a new program: Weather Station Maintenance and Calibration (WMP.1430). In 2025, the new program will target maintenance and calibration of the 216 weather stations.

The Weather Station Network increases situational awareness and obtains foundational data for operational and mission critical activities, including air temperature, wind speed, wind gust, wind direction, and relative humidity. Each weather station transmits data every 10 minutes via cellular and spread spectrum radio. Calibration and maintenance of weather stations is crucial for obtaining accurate, reliable, and high-quality data. Weather station instruments are calibrated annually in alignment with National Weather Service (NWS) procedures and internal procedures. Maintenance also includes routine replacement of aging sensors.

Beginning in 2025, maintenance and calibration activities on the 216 weather stations will be reported via the Quarterly Data Report (QDR) process.

#### 4.1.2 Air Quality Station Maintenance (WMP.1431)

The Air Quality Management Program (WMP.970) is evolving into a new program: Air Quality Station Maintenance (WMP.1431). In 2025, the new program will target maintenance and calibration of the 16 particulate sensors.

The purpose of particulate sensors is to protect employees from Particulate Matter (PM) 2.5 exposure by quickly notifying them when PM2.5 Air Quality Index (AQI) thresholds are exceeded so that they can take protective measures. Maintenance of the particulate sensors will include a scheduled monthly, quarterly, and annual inspection. Each visit will include a rigorous preventative maintenance to ensure accurate functioning of the sensors.

Beginning in 2025, maintenance and calibration activities on the 16 particulate sensors will be reported via the QDR process.

### 4.2 Discontinuance of a Program

---

The Weather Station Network and NDVI Cameras (WMP.447) and the Air Quality Management Program (WMP.970) are evolving into new programs: Weather Station Maintenance and Calibration (WMP.1430) and Air Quality Station Maintenance (WMP.1431). Therefore, Weather Station Network and NDVI Cameras (WMP.447) and the Air Quality Management Program (WMP.970) initiatives will be retired. Details on the new programs can be found in Section 4.1.



## 5 Progress on Areas for Continued Improvement

---

This section provides required progress on the Areas of Continued Improvement identified by the OEIS.<sup>17</sup>

### 5.1 SDGE-23-01: Cross-Utility Collaboration on Risk Model Development

---

#### Description

SDG&E and the other IOUs have participated in past Energy Safety-sponsored risk model working group meetings. The risk model working group meetings facilitate collaboration among the IOUs on complex technical issues related to risk modeling. The risk model working group meetings are ongoing.

Discussed in Section 6, “Risk Methodology and Assessment.”

#### Required Progress

SDG&E and the other IOUs must continue to participate in all Energy Safety-led risk model working group meetings.

#### SDG&E Response

The Joint investor-owned utilities (IOUs) look forward to continued engagement in Energy Safety-sponsored risk modeling working group (RMWG) meetings. These meetings have been valuable to discuss technical aspects of wildfire and PSPS risk modeling for planning and operational purposes. They allow a venue for Energy Safety to gather multiple perspectives from various stakeholders, including utilities, state agencies, and intervening parties. We believe these working group meetings complement similar working groups sponsored by the International Wildfire Risk Mitigation Consortium (IWRMC) and the Edison Electric Institute (EEI). The Joint IOUs appreciate that Energy Safety revised the cadence and organization of these meetings in 2023, most notably the development of a schedule of topics for discussion well in advance of each session. These modifications have allowed utilities to properly prepare for working group sessions, ensure appropriate subject matter experts are available, and allow utilities to balance internal resource constraints, particularly during peak wildfire season.

The RMWGs have allowed for SDG&E to benchmark against the other IOUs when discussing risk analytics best practices, identifying potential areas of improvement and getting diverse perspectives from academia, industry partners, and stakeholders. Additionally, collaborations in the RMWGs have further strengthened relationships and alignment with other IOUs and industry partners.

---

<sup>17</sup> Decision on 2023-2025 Wildfire Mitigation Plan; San Diego Gas & Electric Company, Section 11; <https://efiling.energysafety.ca.gov/eFiling/Getfile.aspx?fileid=55555&shareable=true>

## 5.2 SDGE-23-02: Calculating Risk Scores Using Maximum Consequence Values

---

### Description

SDG&E's use of maximum consequence values, as opposed to probability distributions, to aggregate risk scores is not aligned with fundamental mathematical standards and could lead to suboptimal mitigation prioritization decisions.

Discussed in Section 6, "Risk Methodology and Assessment."

### Required Progress

In its 2025 Update, SDG&E must:

- Provide a plan with milestones for transitioning from using maximum consequence values to probability distributions in its 2026-2028 Base WMP when aggregating risk scores for the following:
  - Mitigation evaluation
  - Cost/benefit calculations
  - Risk ranking
- If SDG&E is unable to transition to using probability distributions or averages, it must:
  - Propose an alternative strategy or demonstrate that its current methodologies are providing accurate outputs for calculating known risk. SDG&E must provide concrete validations, including estimations for usage of maximums, averages, and probability distributions where possible. Explain why or how it is unable to move toward the use of probability distributions when aggregating risk scores. This must include discussion of any existing limitations or potential weaknesses.
  - Provide an explanation for each calculation of risk scores where SDG&E is aggregating risk scores in which maximum consequence was used.
  - Describe any steps SDG&E is taking to explore use of the probability distributions in the future.

### SDG&E Response

Considering the constraints outlined in discussions during the CalOEIS 2023 Risk Modeling Workshops between academia, industry leaders, and IOU subject matter experts that highlighted the challenges in modeling fire suppression, urban conflagration, and other contributing factors, experts in wildfire modeling have not currently reached a universal consensus on how to model long-duration fire events. Examples of highly destructive historical events include the Cedar Fire (2003) and Witch Fire (2007), which can affect over 200,000 acres and result in the destruction of numerous structures within the service territory, leading to losses exceeding billions of dollars.

In the absence of a universally acknowledged approach for forecasting prolonged firestorm events, SDG&E's current methodology for estimating wildfire consequence uses the maximum acres burned and structures destroyed estimates from the 8-hour duration version of Technosylva's FireSight model. However, in an effort to align with the 2025 Risk Assessment Mitigation Phase (RAMP) cost-benefit

framework, the validity and application of probability distributions in the WiNGS-Planning model will be examined and adjustments will be made as deemed necessary to enhance the model's accuracy and effectiveness in supporting risk assessment and mitigation efforts.

The current method of using maximum consequence scores in the WiNGS-Planning model is based on the simulation duration limitations in Technosylva's FireSight model (referred to as the Wildfire Risk Reduction Model [WRRM] in the 2023-2025 Wildfire Mitigation Plan). As of this writing, the production version of WiNGS-Planning uses an 8-hour simulation duration; however, a new version of the FireSight model that uses a 24-hour simulation duration will be explored as a potential complement to the 8-hour model version.

In 2024, the use of probability distributions for consequence values will continue to be explored. Various methodologies and approaches are being researched and developed in conjunction with ongoing internal stakeholder validation. By early 2025, consequence methodology is expected to be aligned with the cost/benefit methodology outlined in CPUC Decision 22-12-027<sup>18</sup>, which requires a shift from a MAVF to the Cost Benefit Approach in the 2025 RAMP filing. In the 2026-2028 Wildfire Mitigation Plan, it is anticipated that the Cost Benefit Approach will be included.

The WiNGS-Ops model will continue to use Technosylva's maximum consequence values, derived from calculations based on the worst fire days in the service territory along with daily run estimates determined from forecasted weather conditions. Daily run estimates will eventually be used to generate a wildfire consequence probability distribution that will be evaluated against the maximum consequence values. The outcome of this evaluation may have an impact on the future direction of the wildfire consequence module in the WiNGS-Planning model.

To support the move towards probability distributions, two parallel, exploratory development tracks will occur within the WiNGS-Planning model in 2024. The first track will focus on incorporating WiNGS-Ops methodology into WiNGS-Planning. A major component of this task will include the development of a probability distribution consequence score built on Technosylva's Wildfire Analyst (WFA) daily model runs. This method has a congenital dependency that requires a minimum time period of at least 1 year in order to generate an accurate distribution of weather conditions for the service territory. The second development track will focus on implementing probability distributions using the existing annual FireCast model output.

Additionally, the incorporation of an alternative wildfire consequence model that estimates values based on a probabilistic framework into existing risk calculations is being explored. The integration of this probabilistic model is currently being studied for use in the WiNGS-Planning wildfire consequence model. Likewise, the percentile attributes from the FireCast model will continue to be evaluated for the most appropriate usage within the mitigation decision framework in relation to mitigation type as well as priority.

Research and development into various methodologies, evaluation of different approaches, and validation with stakeholders will continue. In addition, a feature has been generated in the development work management system to score this enhancement's business value and rank its priority compared to other tasks in the WiNGS-Planning model.

---

<sup>18</sup> CPUC Decision 22-12-027; <https://docs.cpuc.ca.gov/PublishedDocs/Published/G000/M500/K014/500014668.PDF>

To accommodate the change from maximum consequence values to probability distributions, a number of steps will need to be completed. The base plan for transitioning to probability distributions is detailed in Table 9.

### WINGS Planning Cost/Benefit Transition Plan

Objective: Transitioning from using maximum consequence values to probability distributions by the 2026-2028 WMP cycle when aggregating risk scores for the following:

- Mitigation evaluation
- Cost/benefit calculations
- Risk ranking

**Table 9: WiNGS-Planning Cost/Benefit Transition Plan**

Milestone	Dependency	Target Implementation
Complete Span-level model transition	Successfully transition existing risk framework from segment level risk evaluation to span level risk evaluation.	Q2 2024
Complete Exploratory Data Analysis on wildfire consequence probability distributions	Understand differences between percentiles in the FireCast attribute outputs and the effects they have on mitigation selections.	Q2 2024
Generate distribution of wildfire consequence scores over daily wildfire consequence predictions	Explore the transition from 141 worst fire weather days to distribution derived from daily runs. Compare distributions between methods.	2026-2028 Wildfire Mitigation Plan
Decide on appropriate wildfire consequence model to use in WiNGS-Planning	Compare 8-hour, 24-hour, and RMS model for validity in WiNGS-Planning	Q4 2024
Impute missing FireSight values	Apply the nearest neighbors approach to fill in FireSight values for any assets with missing data. Collaborate with Technosylva to identify and minimize the instances of missing values, which typically occur when pole IDs are updated in SDG&E's GIS system.	Q3 2024
Perform research and development on mitigation evaluation impacts	Evaluate scenarios using various statistics and return periods. Examine mitigation pivots between model versions.	2025 RAMP
Evaluate risk ranking impacts	Examine risk ranking pivots between model versions.	2025 RAMP
Transition from Risk Spend Efficiencies (RSEs) to Cost-Benefit Ratios (CBRs)	Outline and finalize cost/benefit methodology.	2025 RAMP
Enhance WiNGS-Planning Visualization Platform	Enable scenario analysis in the WiNGS-Planning Visualization Platform so that subject matter experts can identify appropriate mitigations.	2025 RAMP
User acceptance	Validate and verify the model.	2026-2028 Wildfire Mitigation Plan

## 5.3 SDGE-23-03: PSPS and Wildfire Risk Trade-Off Transparency

---

### Description

SDG&E does not provide adequate transparency regarding PSPS and wildfire risk trade-offs, or how it uses risk ranking and risk buy-down to determine risk mitigation selection.

Discussed in Section 6, “Risk Methodology and Assessment”; Section 7, “Wildfire Mitigation Strategy Development.”

### Required Progress

In its 2025 Update, SDG&E must describe:

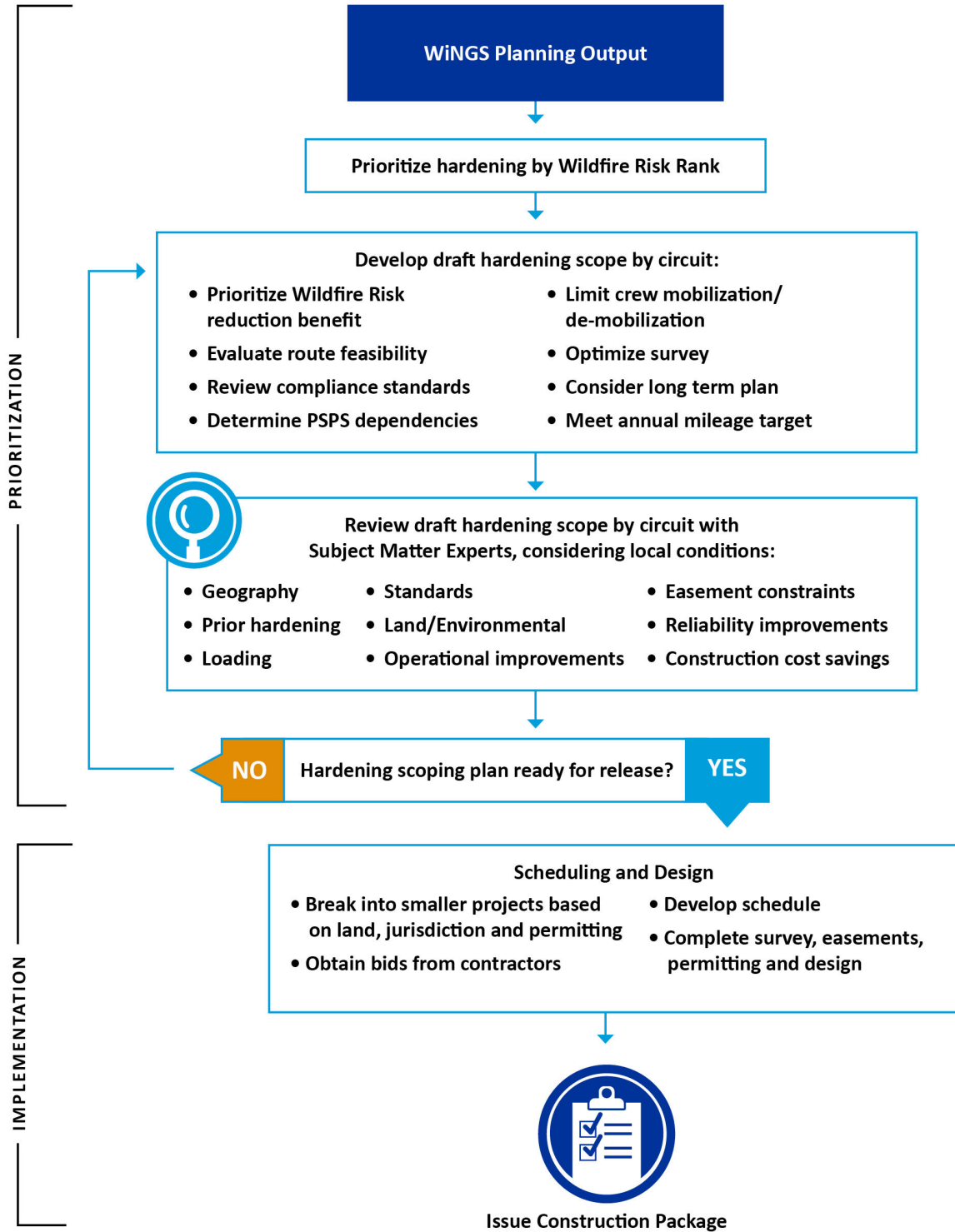
- How it prioritizes PSPS risk in its risk-based decisions, including trade-offs between wildfire risk and PSPS risk.
- How the rank order of its planned mitigation initiatives compares to the rank order of mitigation initiatives ranked by risk buy-down estimate, along with an explanation for any instances where the order differs.

### SDG&E Response

#### 5.3.1 PSPS Risk Prioritization in Risk-Based Decisions

The WiNGS-Planning model leverages PPS LoRE and PPS CoRE. LoRE is estimated as the annual frequency of a risk event in a given year, while CoRE is estimated based on the MAVF. These risk scores are coalesced into an overall PPS risk score. As of this writing, WiNGS-Planning computes PPS risk estimates at the circuit segment level; however, this information is not integrated into the circuit segment RSE score, which is utilized for the selection of appropriate mitigations. Instead, PPS risk estimates are leveraged during the scoping process to determine where PPS benefits can be achieved while prioritizing wildfire mitigations (see Figure 1 for details on the wildfire mitigation prioritization process). The RSE of strategic undergrounding is always the first wildfire mitigation evaluated because of the associated PPS risk reductions that are achieved through undergrounding electric wire. Future releases of WiNGS-Planning are expected to include PPS risk in the mitigation decision framework (see Figure 10 for the WiNGS-Planning calculation schematic).

Figure 1: High-Level Mitigation Prioritization to Reduce Wildfire and PSPS Risk



Source: 2023-2025 Wildfire Mitigation Plan, Section 7.1.4.2.4 Figure 7-4

### 5.3.2 Comparison of Planned Mitigation Initiative Rank Order with Risk Buy-Down Estimate Rank Order

Table 10 compares the rank order of planned mitigation initiatives to wildfire and PSPS risk rank orders. It was developed with the latest WiNGS-Planning model (version 3.0) and also provides an explanation of scope and prioritization adjustments based on additional considerations such as PSPS dependencies, route feasibility, land/environmental concerns, easement constraints, and recently hardened segments. It is important to note that projected risk ranks change per year based on planned work scope.

**Table 10: Ranking of Planned Mitigation Initiatives**

Feeder ID	Segment ID	Wildfire Risk Rank	PSPS Risk Rank	Year Hardening Mitigations Will Begin	Year at which Risk Reduction reaches 50%	Year at which Risk Reduction reaches 75%	Year Hardening Mitigations Will End	Percentage of Total Risk Mitigated in the Final Year	Explanation for Prioritization Adjustments
237	237-30R	1	137	2025	2025	2025	2029	100%	93% of circuit segment miles will be hardened by the end of 2026. Because 7% of remaining miles were recently hardened through traditional hardening, the remainder it not scoped until 2029.
909	909-805R	2	131	2023	2026	2026	2026	100%	No adjustments
222	222-1401R	3	246	2023	2025	2025	2025	100%	No adjustments
524	524-69R	4	104	2025	2025	2025	2025	100%	No adjustments
222	222-1364R	5	9	2023	2025	2028	2028	100%	No adjustments
448	448-11R	6	25	2023	2031	2031	2031	100%	Because this segment was recently hardened through traditional hardening, it is not scoped for undergrounding until 2031
217	217-983R	7	178	2024	2024	2024	2024	100%	No adjustments
222	222-1370R	8	13	2023	2025	2025	2025	100%	No adjustments
358	358-682F	9	69	2024	2024	2028	2028	100%	Segment not included in 2027 due to its wildfire risk ranking; instead, segments with lower risk rank were included to maximize construction efficiencies and PSPS benefits.



Feeder ID	Segment ID	Wildfire Risk Rank	PSPS Risk Rank	Year Hardening Mitigations Will Begin	Year at which Risk Reduction reaches 50%	Year at which Risk Reduction reaches 75%	Year Hardening Mitigations Will End	Percentage of Total Risk Mitigated in the Final Year	Explanation for Prioritization Adjustments
157	157-81R	10	155	2023	2026	2027	2027	100%	Undergrounding scope delayed on the following basis: <ul style="list-style-type: none"> <li>• Future covered conductor efficacy updates could change model recommendations</li> <li>• There is no additional PSPS benefit from undergrounding because of covered conductor planned upstream</li> </ul>
1030	1030-989R	11	246	2027	2027	2027	2027	100%	No adjustments
79	79-808R	12	195	2023	2023	2026	2026	100%	No adjustments
73	73-643R	13	65	2023	2023	2024	2026	100%	No adjustments
237	237-1765R	14	132	2025	2025	2025	2025	100%	No adjustments
214	214-1122R	15	95	2025	2025	2025	2025	100%	No adjustments
1215	1215-32R	16	246	2024	2024	2024	2024	100%	No adjustments
237	237-17R	17	246	2025	2025	2025	2025	100%	No adjustments
220	220-298R	18	246	2023	2024	2026	2026	100%	No adjustments
217	217-837R	19	21	2025	2027	2027	2027	100%	Undergrounding scope delayed on the following basis: A single outlier wind event drives the undergrounding recommendation, which is pending further analysis. There is limited PSPS benefit due to overhead that remains downstream

Feeder ID	Segment ID	Wildfire Risk Rank	PSPS Risk Rank	Year Hardening Mitigations Will Begin	Year at which Risk Reduction reaches 50%	Year at which Risk Reduction reaches 75%	Year Hardening Mitigations Will End	Percentage of Total Risk Mitigated in the Final Year	Explanation for Prioritization Adjustments
73	73-683R	20	246	2026	2026	2026	2026	100%	No adjustments
157	157-232R	21	41	2026	2026	2029	2029	100%	No adjustments
445	445-1311R	22	246	2023	2024	2029	2029	100%	No adjustments
235	235-899R	23	246	2027	2027	2027	2027	100%	Hardening scoping In-Progress by ESH and Risk Analytics teams
222	222-2013R	24	246	2023	2028	2028	2028	100%	Hardening scoping In-Progress by ESH and Risk Analytics teams
521	521-14R	25	82	2025	2027	2027	2027	100%	Hardening scoping In-Progress by ESH and Risk Analytics teams
970	970-1341R	26	17	2027	2027	2027	2027	100%	Hardening scoping In-Progress by ESH and Risk Analytics teams
217	217-835R	27	246	2027	2027	2027	2027	100%	Hardening scoping In-Progress by ESH and Risk Analytics teams
216	216-1857	28	146	2025	2025	2025	2030	100%	No adjustments

*\*Appropriate wildfire mitigations are strategically applied based on the WiNGS-Planning model; however, previous traditional hardening efforts are also considered when prioritizing undergrounding in order to reduce costly duplicitous hardening efforts.*

## 5.4 SDGE-23-04: Incorporation of Extreme Weather Scenarios into Planning Models

---

### Description

SDG&E currently relies on wind conditions data representing the past 13 years that do not consider rare but foreseeable and significant risks. SDG&E does not evaluate the risk of extreme wind events in its service territory to prioritize its wildfire mitigations using WiNGS-Planning.

Discussed in Section 6, “Risk Methodology and Assessment.”

### Required Progress

In its 2026-2028 Base WMP, SDG&E must report on its progress developing statistical estimates of potential wind events over at least the maximum asset life for its system and evaluate results from incorporating these into WiNGS-Planning when developing its mitigation initiative portfolio or explain why the approach would not serve as an improvement to its mitigation strategy.

### SDG&E Response

SDG&E will report on the progress on ACI SDGE-23-04 Incorporation of Extreme Weather Scenarios into Planning Models in its 2026-2028 Wildfire Mitigation Plan, as requested by the OEIS.

## 5.5 SDGE-23-05: Cross-Utility Collaboration on Best Practices for Inclusion of Climate Change Forecasts in Consequence Modeling, Inclusion of Community Vulnerability in Consequence Modeling, and Utility Vegetation Management for Wildfire Safety

---

### Description

SDG&E and the other IOUs have participated in past Energy Safety-sponsored scoping meetings on these topics but have not reported other collaboration efforts.

Discussed in Section 7, “Wildfire Mitigation Strategy Development”; Section 8.2, “Vegetation Management and Inspections.”

### Required Progress

SDG&E and the other IOUs must participate in all Energy Safety-organized activities related to best practices for:

- Inclusion of climate change forecasts in consequence modeling.
- Inclusion of community vulnerability in consequence modeling.
- Utility vegetation management for wildfire safety.

SDG&E must collaborate with the other IOUs on the above-mentioned best practices. In their 2025 Updates, the IOUs (not including independent transmission operators) must provide a status update on any collaboration with each other that has taken place, including a list of any resulting changes made to their WMPs since the 2023-2025 WMP submission.

### **SDG&E Response**

The IOUs collaborate and engage through recurring RMWGs, as well as weekly Joint IOU Enterprise Risk Management, monthly PSPS Joint IOU meeting, and sub-committee meetings, which focus on risk and emergency operations, weekly WMP Joint IOU call, and monthly WMP Joint IOU alternate virtual and in-person meetings

#### **5.5.1 Inclusion of Climate Change Forecasts in Consequence Modeling**

The joint IOUs participated in Energy Safety-organized activities related to inclusion of climate change forecasts in consequence modeling and welcomes continued discussion on this topic. Methodology was presented for integrating global climate models into wildfire consequence models using a 2030 climate change analysis at an OEIS sponsored workshop in July 2023 using information from California's Fourth Climate Assessment. The joint IOUs also note that they are participating in the Climate and Risk-Based Decision-Making Framework (RDF) proceedings pending before the Commission, where integration of climate models into the risk-based decision-making framework is an active topic of discussion and work on California's Fifth Climate Assessment is ongoing.

#### **5.5.2 Inclusion of Community Vulnerability in Consequence Modeling**

The joint IOUs participated in Energy Safety-organized activities related to inclusion of community vulnerability in consequence modeling and welcome continued discussion on this topic. Methodology was presented for integrating social vulnerability into wildfire and PSPS de-energization consequence models at an OEIS-sponsored workshop in May 2023.

#### **5.5.3 Utility Vegetation Management for Wildfire Safety**

The joint IOUs actively participate in utility vegetation management collaborative efforts such as the Study for Effectiveness of Enhanced Clearances, with the objective of developing a standardized cross-utility database monitoring the effectiveness of enhanced clearances and tree-caused circuit interruptions. This ongoing initiative includes recurring, bi-weekly meetings amongst the utilities, along with occasional, direct participation from Energy Safety.

The joint IOUs have also collaborated on the Annual Benchmarking of Best Practices in Quality-related areas, with the objective of understanding each IOU's QA/QC program as they relate to assuring vegetation work is performed to regulatory and other compliance standards. The latter effort includes focus areas for QC (e.g., discussions on the type and frequency of inspections), QA, Training, and Quality Records Management. In addition to these formal efforts, relationships built between peer IOUs have opened greater lines of communication for other discussions such as debris management practices. In 2023, Southern California Edison (SCE), Pacific Gas & Electric (PG&E), and SDG&E held two working sessions to discuss the different types of programs and practices each IOU has in place for disposing and recycling woody debris and vegetation. Also in 2023, the joint IOUs held a meeting to discuss each

utility's respective fuels management programs and began initial collaboration on a possible scoping study on best practices and efficacy of fuels management.

The joint IOUs are founding members of the International Wildfire Risk Mitigation Consortium, which was formed to address best management practices for utility vegetation management for wildfire risk abatement. Multi-national utilities participate in this initiative, providing comprehensive awareness, a science-based approach, and solution-oriented perspectives. Meetings and webinars are held monthly and cover a wide range of topics including hazard tree assessment, remote sensing technology, and risk modeling.

The joint IOUs welcome continued discussion on these and other utility vegetation management topics.

## SDGE-23-06: Demonstration of Proper Decision Making for Selection of Undergrounding Projects

---

### Description

SDG&E is often prioritizing undergrounding over other mitigations through its mitigation decision-making process and does not provide adequate justification for its undergrounding projects.

Discussed in Section 7, "Wildfire Mitigation Strategy Development."

### Required Progress

In its 2025 Update, SDG&E must:

- Demonstrate adequate risk reduction for any areas planned for undergrounding via interim mitigation strategies, accounting for all ignition risk drivers.
- Provide an analysis demonstrating its process for the selection of undergrounding projects, which must include:
  - Location-specific ignition driver analysis.
  - Location-specific undergrounding effectiveness compared to combinations of mitigations (such as covered conductor, early fault detection, falling conductor protection, other advanced protection, and sensitive relay profile).
  - Developing an estimate of the cumulative risk exposure of its mitigation initiative portfolio taking into account the time value of risk as part of mitigation comparisons.
  - PSPS risk when choosing mitigations and locations, including supporting materials for how PSPS risk was calculated (such as frequently de-energized circuits selected for undergrounding).
- If applicable, adjustments to SDG&E's hardening scope to account for the above evaluation. If SDG&E is not adjusting its hardening scope, it must provide an explanation as to why adjustments are not necessary

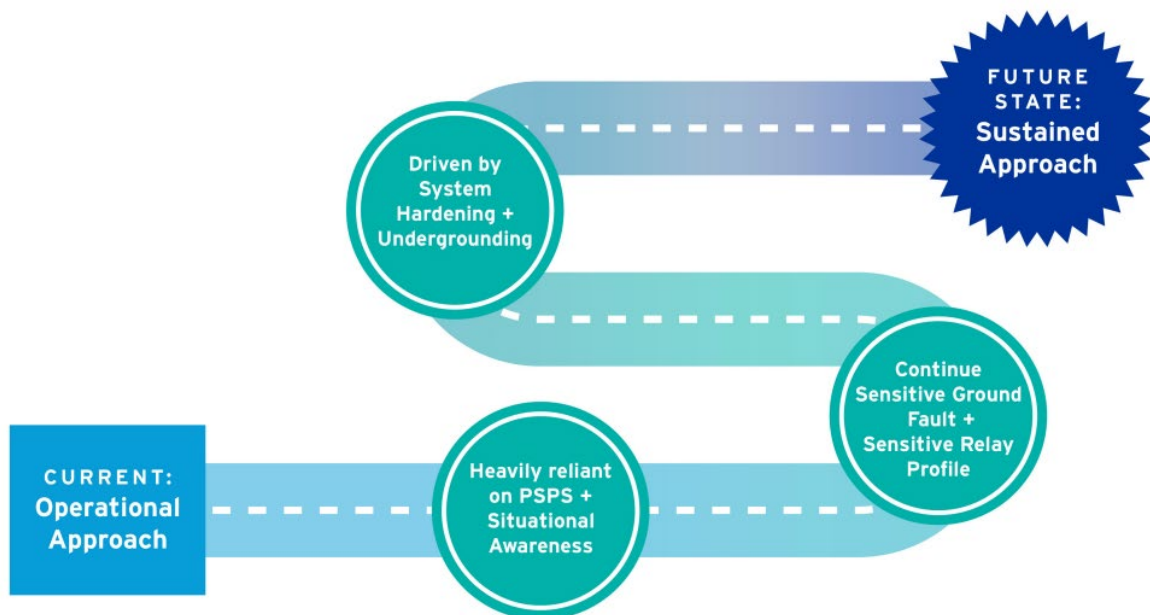
### SDG&E Response

SDG&E remains a global leader in wildfire mitigation and is working to eliminate the need for PSPS de-energizations as a wildfire risk mitigation tool.

In the past decade, wildfire prevention and mitigations across a wide spectrum of disciplines and activities have been revamped and enhanced, including strengthening and protecting infrastructure, improving situational awareness and data analysis, enhancing weather technology, and increasing the impact of community outreach.

Our current state is an operational approach (see Figure 2) that is heavily reliant on PSPS de-energizations and situational awareness mitigations such as setting sensitive relay profiles (SRP) or sensitive ground faults (SGF), some of which require human intervention, which potentially can introduce human error and do not completely eliminate risk on the system. In our future state, SDG&E will utilize the WiNGS-Planning model to consider both the reduction of wildfire risk and PSPS de-energization impacts. This approach aims for a permanent and non-operationally dependent solution, seeking to minimize the full-cycle cost of the hardening solution and mitigate community impacts through a data-driven methodology that optimizes investment decisions. The WiNGS-Planning model has incorporated key inputs and refinements, leading to an anticipated portfolio of approximately 1,500 miles of strategic undergrounding of electric lines (WMP.473) and 370 miles of covered conductor to be installed (WMP.455) between 2022 and 2032. Over the next 10 years, if this plan is implemented, much of the service territory located in the HFTD will be hardened, reducing the reliance on human intervention, reducing the wildfire risk, and eliminating the need for PSPS de-energizations in the service territory.

**Figure 2: Long-Term Risk Reduction Approach**



Transitioning from an operational to sustainable long-term risk reduction approach also mimics the well-known Hierarchy of Controls methodology (see Figure 3). The most effective method to safeguard against a hazard is to eliminate the hazard altogether. For wildfire and PSPS risk, this is accomplished through the long-term mitigation strategies of covered conductor installation and strategic

undergrounding of electric lines. When these mitigations are not possible or if they will take time to implement, engineering and administrative controls are implemented in the interim. Initiatives such as SRP and PPS de-energizations are engineering controls that can reduce the hazard of wildfire, while SDG&E's practice of canceling non-essential work during extreme FPI days and regular training on wildfire hazards are administrative controls that change the way work is performed in order to reduce the likelihood of ignition.

**Figure 3: Hierarchy of Risk Controls**

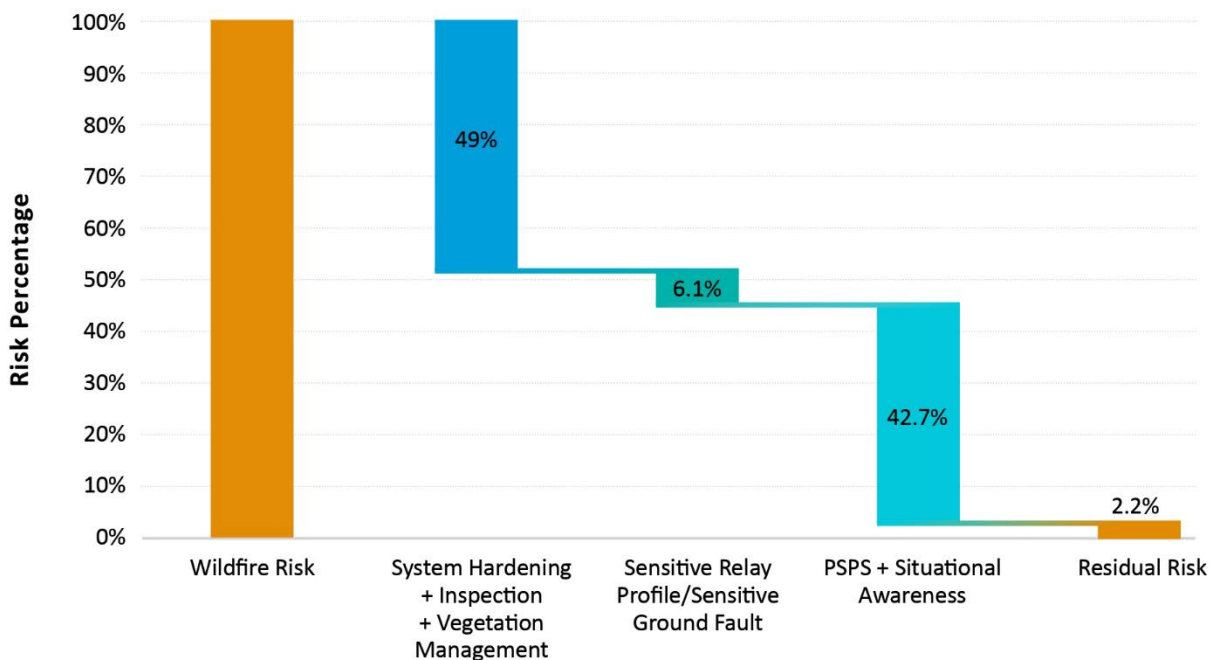


#### 5.5.4 Interim Mitigation Strategies for Risk Reduction

Historically, operational wildfire risk mitigations such as PPS de-energizations and turning off dynamic protective device reclosing mechanisms have been implemented during wildfire season. While these operational mitigations have proven effective as evidenced by the fact that no significant wildfires have been caused by SDG&E's system since 2007, operational mitigations are fundamentally flawed in that the inherent risk remains in the grid. As represented in the Hierarchy of Risk Controls (Figure 3) and best industry practices to reduce safety risks, the first mitigation to consider should be elimination of any risk. Therefore, there has been a shift to hardening the system against wildfire risk through sustainable strategies including undergrounding electric lines and installing covered conductor. While undergrounding is the most effective wildfire mitigation available to electric utilities, it takes time to implement; it is estimated that it will take 10 years to complete all mitigations in the undergrounding portfolio. Covered conductor installation has a similar implementation timeframe; covered conductor projects are typically completed in 20 to 35 months and undergrounding projects are typically completed in 24 to 36 months. During that timeframe, segments that are awaiting construction are mitigated through operational mitigations such as PPS de-energizations and SRP.

Figure 4 displays the effectiveness of various wildfire risk reduction strategies implemented since 2007 in the service territory. There has been an approximately 98% reduction in wildfire risk through these operational mitigations, most of which are interim mitigations.

**Figure 4: Effectiveness of Hardening Strategies to Wildfire Risk (Years 2007-2023)**



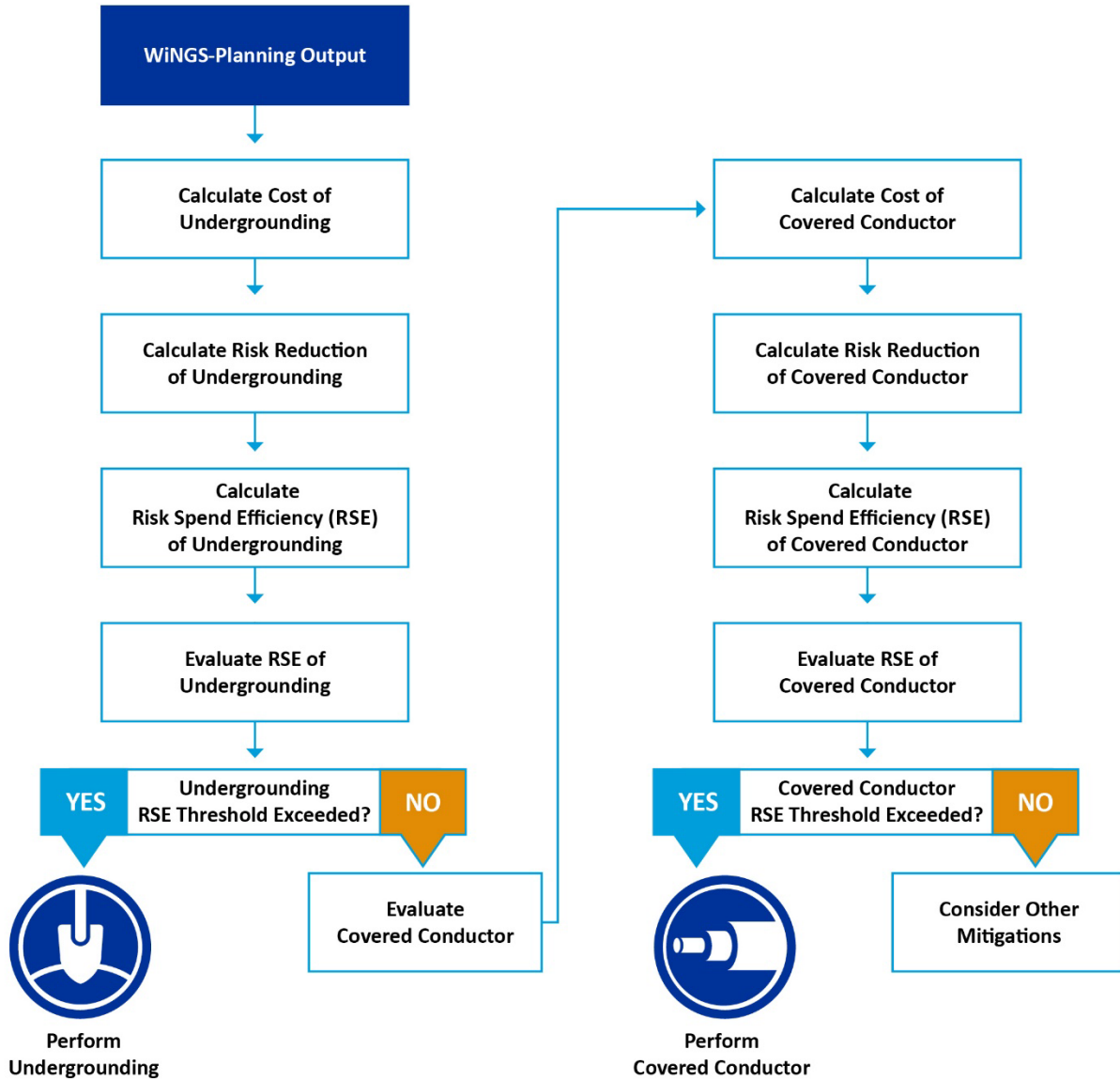
### 5.5.5 Selection Process for Undergrounding Projects

The process for selecting undergrounding projects begins with the WiNGS-Planning model. This model incorporates wildfire risk into a RSE framework to determine cost effective applications of strategic undergrounding and covered conductor with a risk reduction target of approximately 80%. While PSPS risk is an output in the WiNGS-Planning model that is used to guide the mitigation selection process, it is currently not incorporated into the mitigation selection framework of the model.

The first step in the mitigation selection process is to determine which circuit segments qualify for strategic undergrounding and/or covered conductor by comparing each mitigation’s respective RSE score to each mitigation RSE threshold. Both covered conductor and strategic undergrounding mitigations are evaluated for every segment in the portfolio. After the RSE thresholds for strategic undergrounding and covered conductor have been evaluated, a decision tree is implemented to determine which mitigation will be recommended in the final model output, as shown in Figure 5.

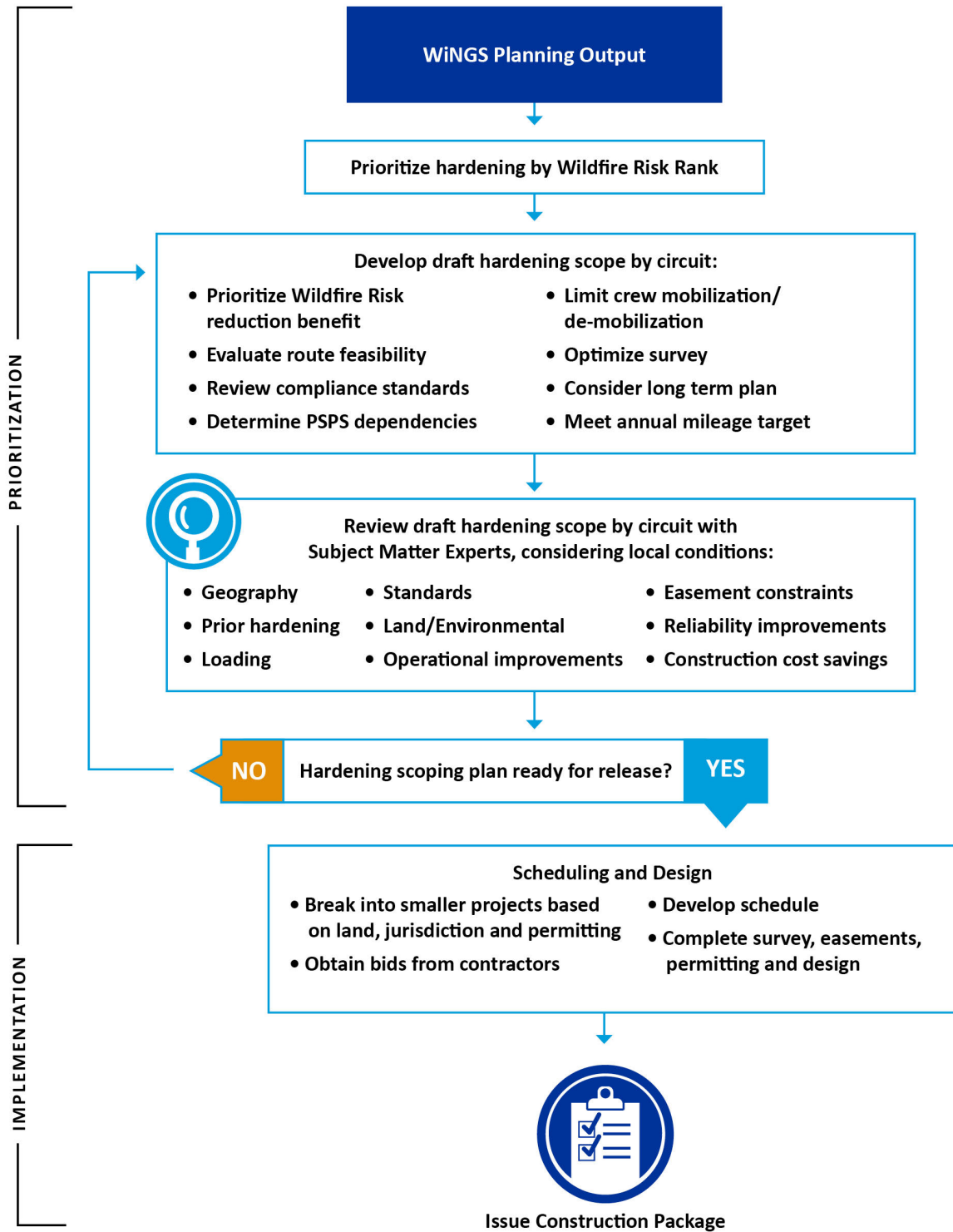


Figure 5: WiNGS-Planning Mitigation Decision Tree



While the WiNGS-Planning model supplies a quantified mitigation recommendation, the final step in the mitigation selection process resides with the scoping engineers (see Figure 6 for the mitigation prioritization process). During the scoping process, a desktop feasibility study is employed to determine the practicality of the proposed mitigation. PSPS de-energization impacts are also examined during this step. For more information on the desktop feasibility study, see Section 7.1.4.1.3 of the 2023-2025 Wildfire Mitigation Plan.

Figure 6: High-Level Mitigation Prioritization to Reduce Wildfire and PSPS Risk

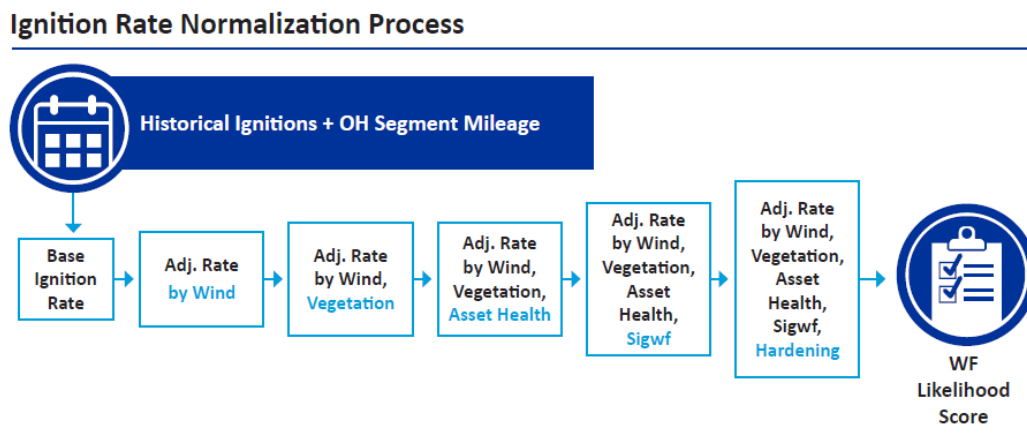


Source: 2023-2025 Wildfire Mitigation Plan; Section 7.1.4.2.4 Figure 7-4

### 5.5.5.1 Location-Specific Ignition Driver Analysis

WiNGS-Planning includes a location-specific ignition driver using an ignition rate normalization process, shown in Figure 7. This process starts with an annual ignition rate in the HFTD that is adjusted by local phenomena such as wind gust, tree strike potential, asset health, and hardening percentages.

Figure 7: WiNGS-Planning Ignition Rate Normalization Process



Source: WiNGS-Planning Model Documentation

### 5.5.5.2 Effectiveness of Undergrounding versus other Mitigations

The following wildfire efficacy assumptions are used in the production version of the WiNGS-Planning model.

- Covered Conductor: 64%
- Undergrounding: 100%

While the efficacy rate of covered conductor varies across IOUs, the current efficacy rate will be maintained until more studies and analyses support the adoption of an alternative efficacy percentage.

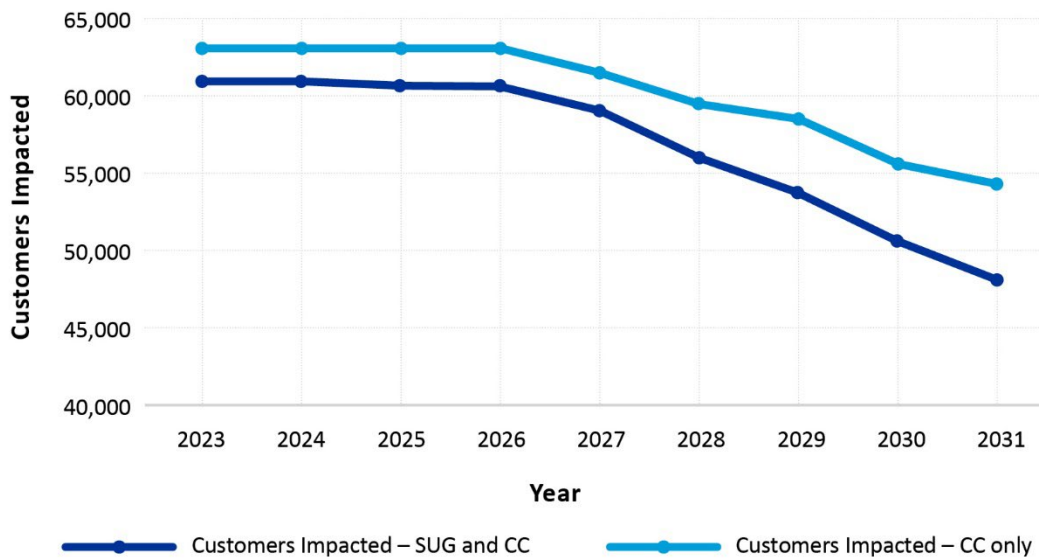
In 2024, a combined mitigation study is being conducted by a third-party vendor to understand the benefits and costs associated with increasing covered conductor effectiveness and how a combination of mitigations compares to undergrounding. Typically, these combined mitigations consist of a primary application of covered conductor coupled with an operational mitigation, such as enhanced tree trimming or removal or sensitive relay profile. The study is also expected to show how interim mitigations fare long-term compared to undergrounding. Results of the study are expected by the end of 2024.

In 2023, a customer impact study was started to examine how the two most effective grid hardening initiatives, strategic undergrounding and covered conductor, affect PSPS customer impact reduction. To date, three approaches to the study have been attempted with varying results. All three approaches look at the most impactful PSPS de-energization event, which affected 73,000 customers in Dec. 2020, with current conditions to see how accomplishments from these two grid hardening initiatives would reduce PSPS impacts to the same group of customers if the same weather event were to occur annually.

In the most exact approach to the study, weather stations connected to de-energized segments from the December 2020 PSPS de-energization were matched to the segment structure in 2023. These matched segments and their associated 73,000 customers serve as the study population. The actual and planned hardening of these segments, which is both undergrounding and covered conductor, is then compared to a hypothetical covered conductor only hardening in terms of annual customer impact.

Preliminary results in Figure 8 show that if the 2020 PSPS event hypothetically occurred annually, undergrounding of electric lines combined with covered conductor installation on these segments would reduce annual PSPS impacts for more customers than covered conductor installation alone. By 2031, PSPS impacts would be reduced for approximately 34% or 24,643 of the 73,000 affected customers when considering both strategic undergrounding of electric lines and covered conductor installation mitigations. Alternatively, if only covered conductor mitigations are considered, preliminary results showed that by 2031, PSPS impacts would be reduced for approximately 26% or 18,908 of the 73,000 affected customers. Comparing the two customer impact reductions, undergrounding combined with covered conductor installation is 30% greater than covered conductor only by 2031.

**Figure 8: Projected PSPS Impact Reduction**

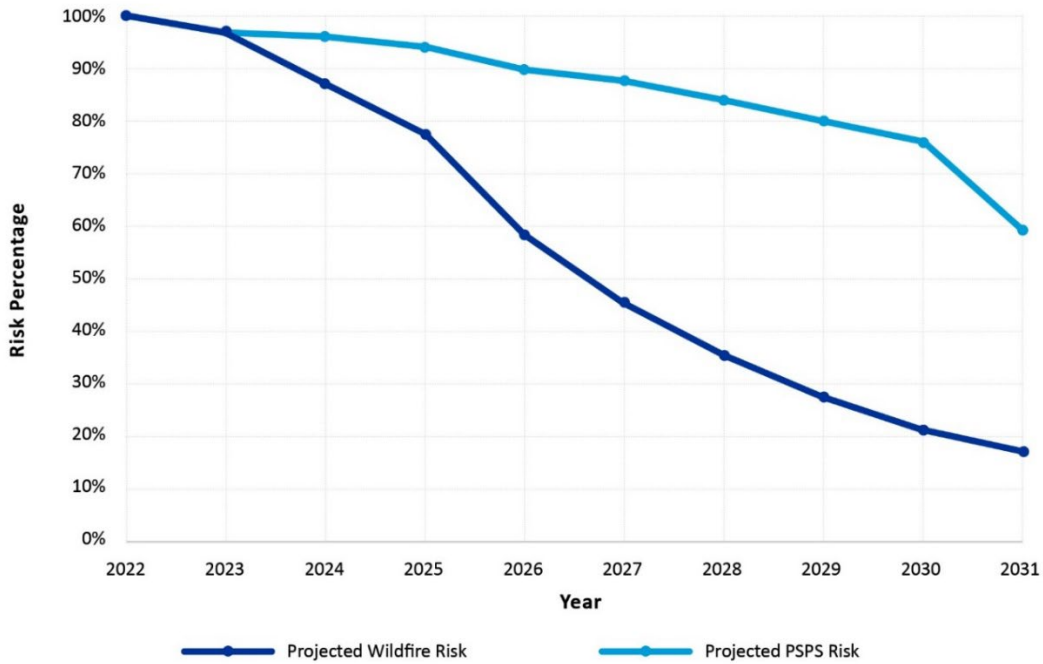


This study will be refined in 2024 and 2025 to track the efficacy of wildfire mitigation grid hardening accomplishments on PSPS customer impact reduction.

### 5.5.5.3 Cumulative Risk Exposure of the Mitigation Initiative Portfolio

The mitigation portfolio for the WiNGS-Planning model is tuned to reduce the risk of wildfire in the HFTD by approximately 80%. Figure 9 displays expected wildfire risk reduction on an annual basis.

**Figure 9: Annual Expected Risk Reduction (Years 2022-2031)**



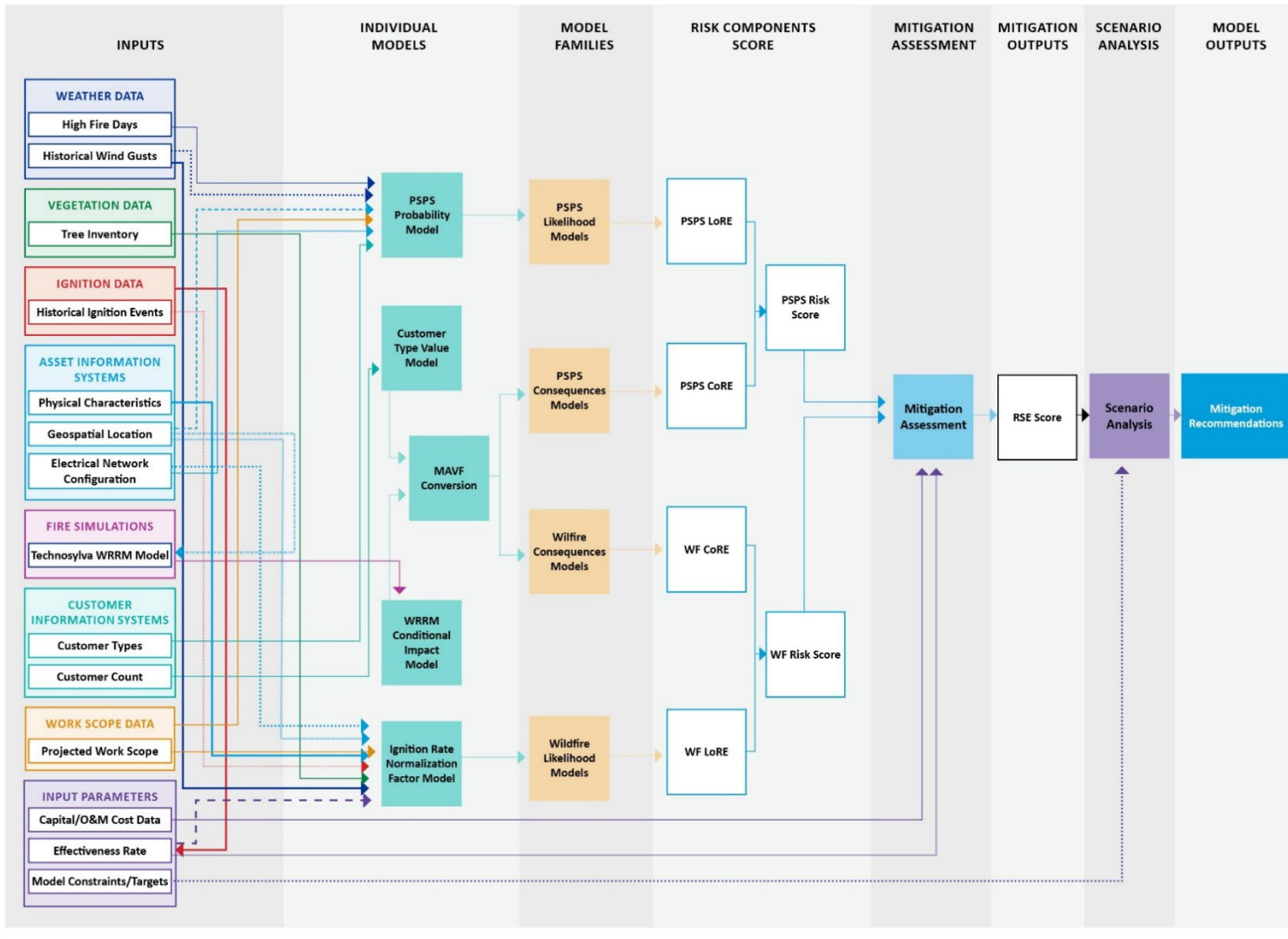
Until construction has been completed on the entire wildfire mitigation portfolio, operational mitigations in the form of PSPS de-energizations, annual visual inspections, tree trimming/ removal, and expulsion fuse replacement will continue to be implemented in order to reduce wildfire risk. Most of these operational mitigations have been in place since 2007 and have various levels of efficacy as shown in Figure 4.

#### **5.5.5.4 Incorporating PSPS Risk in Mitigation Selection**

PSPS risk is not currently included in RSE calculations and is therefore not part of the mitigation recommendation component of the WiNGS-Planning model (see Section 5.3 ACI SDGE-23-03 for details on PSPS and Wildfire risk trade-off transparency). PSPS risk is however, included as an output of the WiNGS-Planning model, and comprises two of the four major risk components. Figure 10 provides an overview of the WiNGS-Planning model architecture.

A future release of the WiNGS Planning model is expected to include PSPS de-energizations as part of the RSE score and mitigation selection framework. Development on this feature is expected to commence in 2024.

Figure 10: WiNGS-Planning Calculation Schematic



Source: 2023-2025 Wildfire Mitigation Plan; Section 6.2.2 Figure 6-7

Note: RSE Score currently incorporates Wildfire Risk Score only. In future versions, RSE Score will incorporate both Wildfire and PSPS Risk Score.

In the WiNGS-Planning model, PPS risk is calculated by multiplying the PPS LoRE and PPS CoRE.

Values for PPS LoRE are determined through Meteorology subject matter expertise and are based on the probability that a segment or its upstream segments will experience a PPS de-energization during a High Fire Day based on their assessed alert speed thresholds as well the historical average number of High Fire Days observed. PPS LoRE is calculated using the following equation:

$$PPS\ LoRE = Incremental\ Upstream\ PPS\ Probability \times Annual\ Avg\ High\ Fire\ Days$$

The Incremental Upstream PPS Probability is calculated using the following equation:

$$Incremental\ Upstream\ PPS\ Probability = Max(Select\ PPS\ Probability - Maximum\ Upstream\ PPS\ Probability, 0)$$

Where the Select PPS Probability is the probability of a select circuit-segment SCADA switch hitting its set alert speed threshold during a High Fire Day event and the Maximum Upstream PPS Probability is the highest PPS probability of a circuit-segment from a select circuit-segment up to its associated circuit breaker.

Values for PPS CoRE are MAVF values based on the consequence of a PPS de-energization occurring with respect to the expected duration of the de-energization and the number and types of customers that would be affected. The baseline risk inputs are the number of minutes within an expected PPS de-energization, the count of downstream customers, and the associated customer types tied to those counts.

General MAVF Component Equation:

$$Total\ PPS\ CoRE = \sum_{i=1}^3 PPS\ CoRE_i$$

Where Total PPS CoRE is the final PPS CoRE Score, PPS CoRE<sub>i</sub> is the PPS CoRE component of attribute i, and i is one of the three MAVF attribute components (Safety, Financial, Reliability).

Table 11 shows the calculations for PPS CoRE for each of the MAVF attribute components.

**Table 11: MAVF Attribute Calculations for PPS CoRE**

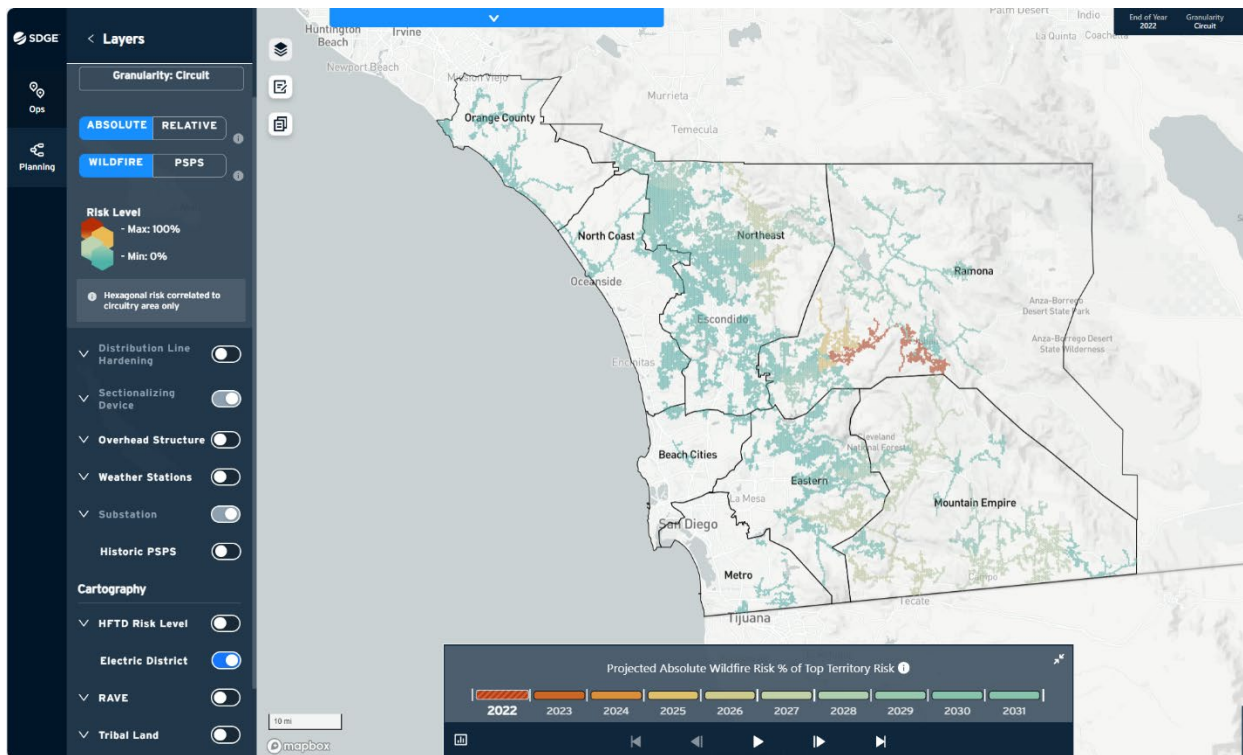
	PPS Methodology*
Safety	number of affected customers × PPS duration × Serious Injuries and Fatalities (SIF) per customer-minutes
Reliability	SAIDI + SAIFI (based on PPS duration)
Financial	number of affected customers × dollars per affected customer

\* Normalization multipliers are implied and not listed explicitly in the equations detailed in the table

### 5.5.5.5 Visualization of Wildfire Risk

The WiNGS-Planning model evaluates both wildfire and PSPS impacts at the segment level, providing guidance for long-term mitigation decisions by identifying suitable measures to reduce wildfire risk. In 2023, a state-of-the-art cloud-based architecture was implemented for visualizing, navigating, and interacting with the outputs of the WiNGS-Planning model. The WiNGS-Planning Visualization Platform (see Figure 11) provides a heatmap that overlays wildfire and PSPS risk, seamlessly integrating electric asset information, local weather and vegetation conditions, customer information, wildfire consequence estimates from third-party vendors, and other essential data necessary for informed decision-making. A time slider feature allows users to simulate risk reduction over time based on model-suggested mitigations. This tool provides circuit- and segment-specific metrics for customers, assets, historical weather conditions, and risk. The self-service model empowers internal subject matter experts to compare different modeled portfolios to evaluate risk reduction and cost-effectiveness.

Figure 11: WiNGS-Planning Visualization Platform



### 5.5.6 Adjustment to Hardening Scope

The mitigation scoping process considers local ignition drivers, mitigation efficacy, risk exposure, and PSPS de-energization benefits when setting mitigation priorities. As described in Section 5.5.5, scoping is a fluid process that is guided by the WiNGS-Planning model. In addition, evaluation of the hardening scope is managed by a consortium of directors from various business units such as Wildfire Mitigation, Portfolio & Project Management, and Electric Engineering. Deviations from model recommendations result from a criterium including re-hardening considerations, terrain issues, proximity efficiencies and



more. See ACI SDGE-23-03, Table 10 for a detailed list of scope adjustments with associated rationale for each change.

In 2023, an internal analysis was performed to understand the combined efficacy of covered conductor, FCP, and EFD, which is described in full detail in Section 5.7 (ACI SDGE-23-08). The results of this study showed that when covered conductor is combined with these other advanced protection initiatives, the efficacy of the combined mitigations is 77% at a combined cost of approximately \$1.6 million per mile. The combined cost and efficacy were utilized as an input into the WiNGS-Planning model as a replacement for solely utilizing covered conductor. This alternative run of the WiNGS Planning model resulted in 20 segments pivoting from no mitigation to covered conductor, and two segments pivoting from undergrounding to covered conductor while achieving the same level of overall wildfire risk reduction. The results are shown in Table 12.

**Table 12: WiNGS-Planning Output Comparison**

	Before	After
Covered Conductor Miles	21	99
Undergrounding Miles	696	633
Cost	\$1,150 Million	\$1,108 Million

These adjustments are expected to be implemented to the hardening scope, which encompasses years 2027 through 2032. Work planned for 2024 to 2026 is already underway and cannot be modified without impacts to completing the work. In addition, while the implementation of covered conductor combined with these advanced protection initiatives will take place, it is unlikely to occur at the same time. This is because a greater risk reduction can be achieved by focusing advanced protection initiatives on circuits that remain with bare conductor, as those circuits will have more remaining risk than those that have been mitigated with covered conductor. Therefore, the current scoping for FCP and EFD will not be modified, except the ongoing modifications to de-scope circuits where there is planned undergrounding.

## 5.6 SDGE-23-07: Third-Party Recommendations for Model Improvements

---

### Description

SDG&E has not provided a plan to implement improvements identified for its risk modeling from its third-party consultant.

Discussed in Section 7, “Wildfire Mitigation Strategy Development.”

### Required Progress

In its 2025 Update, SDG&E must provide an update on its implementation of the following recommended improvements:

- Inclusion of its Vegetation Risk Index and/or other measurement of vegetation-related risk and how this index informs vegetation management decisions.
- Use of its risk model to inform mitigation work outside of grid hardening.
- Sensitivity analysis for risk buy-down, mitigations, and PSPS models.
- Elimination of double-counting of conductor age and circuit health index within models.
- SDG&E must also provide a list of recommendations from the Table of Recommendations in its consultant's May 2023 report that it is adopting with the timeline for each recommendation's implementation and a list of recommendations it is not adopting, if any, with an explanation on why SDG&E is not adopting a recommendation.

### **SDG&E Response**

Implementation priorities for the WINGS-Planning and WINGS-Ops models are continually reevaluated to address the most important items in a timely manner. Many of the recommendations from third-party reviews in 2023 have been evaluated, prioritized, and/or completed. The remaining recommendations are currently being reevaluated, prioritized, or deferred to 2024 and 2025. Business values for model initiatives are classified based on a combination of regulatory requirements, stakeholder/leadership satisfaction, improvements to input/output quality, and improvements to process efficiency. Due to a large number of proposed model improvements and third-party review recommendations, the business value score is used to prioritize the highest-value initiatives.

#### **5.6.1 Inclusion of Vegetation Risk Analytics for Vegetation Operational Decisions**

In 2023, a group of risk-related attributes were tested to support development of the vegetation priority risk model. Attributes of the model that were implemented include visualization of the frequency of priority conditions (i.e., memo tree, hazard tree, outage). These attributes, available to field users, identify which trees may pose a higher risk to electric assets. The output of the first iteration of the vegetation priority risk model was used in 2023 to adjust the schedule of off-cycle patrol activities in the HFTD (WMP.508). In addition, performance of the model was tested in order to identify limitations. Based on results of this testing, the model will shift in 2024 from a tree-based model to a span-based model.

Development of the tree outage probability model, in collaboration with the SDSC, continued in 2023. The first iteration of the model was completed and the output and predictive capabilities are currently being validated. Progress on the model included a wind condition map with visualization.

In 2023, a first iteration dashboard was created using LiDAR tree strike analysis to rank circuit sections using vegetation management inventory tree data and strike tree density. Initial use of this dashboard may include desk-top visualization and scoping activities.

In the WINGS-Planning model, the tree strike index that is used to adjust the annual ignition rate was refreshed and scaled out to the service territory. This process is no longer reliant on consultant updates and can be modified in-house on an as-needed basis. Unlike the VRI, which helps inform PSPS de-energization decisions, the tree strike index assesses the risk of trees contacting distribution lines and does not inform PSPS de-energization decisions.

## 5.6.2 Use of Risk Model to Inform Mitigation Work Outside of Grid Hardening

The current WINGS-Planning model, version 3.0, only recommends mitigations of installing covered conductor (WMP.455) and undergrounding electric lines (WMP.473). Mitigations outside of grid hardening initiatives are not assessed. Beginning in 2024, the efficacy of mitigation combinations will be assessed and depending on the results, the WINGS-Planning model could be expanded to include mitigations outside of grid hardening in conjunction with covered conductor installation.

Currently, mitigation work outside of grid hardening is prioritized through consequence modeling based on the HFTD.

## 5.6.3 Sensitivity Analysis

A sensitivity analysis was conducted to study how increasing the efficacy of covered conductor installation by means of mixed mitigations affected individual proposed mitigations as well as the complete portfolio. Included in this analysis was an increase in cost for covered conductor installation combined with a mixed mitigation strategy. An increase in efficacy from 64% to 77% with a cost increase from \$1.4 to \$1.6 million per mile resulted in two mitigation pivots from undergrounding electric lines to covered conductor installation and 20 mitigation pivots from no mitigation to covered conductor installation.

Sensitivity analyses will continue to be developed throughout the 2023-2025 WMP cycle to better understand the reactivity of the mitigation selection process to each component change within the model.

## 5.6.4 Elimination of Double-Counting of Conductor Age and Circuit Health Index

The conductor age double-counting issue is scheduled to be cleared the first half of 2024 via the larger ignition rate revision project. A requirement of the WINGS Planning ignition rate revision project will be to remove any duplicitous usage of conductor age to assess risk. There are two workstreams that will be launched in 2024 designed to overhaul the WINGS-Planning ignition rate. The first workstream will incorporate the WINGS-Ops ignition rate into the WINGS-Planning model. The WINGS-Ops ignition rate includes a conductor probability of failure model as a component of wind. If adopted, this new ignition rate would no longer use the Circuit Health Index (CHI) or conductor age adjustments currently in the WINGS-Planning ignition rate and would thus eliminate the double-counting issue. The second workstream involves research and development on a new ignition rate designed specifically for the WINGS-Planning model and will seek to eliminate the sequential ignition rate adjustments that currently have the double-counting issue.

### 5.6.5 Third Party Review Recommendations

Table 13 and Table 14 list third-party recommendations for WiNGS-Planning and WiNGS-Ops model improvements. They have been edited for simplicity and clarity; no recommendations have been removed. Severity levels associated with each recommendation are based on the potential impact to model outputs should the recommendation not be implemented.

**Table 13: WiNGS-Planning Third Party Recommendations**

ID	Recommendation Name	Description	Severity Level and Impact	Target Deadline (EOY)	Status
R1.1	Data Ownership	Ensure that there is an integrated function, such that communication from specific data owners is cohesive and timely. This would ensure the communication of definitions, use, bounds for validity, and decisions on changes. Data owners would also be responsible for ensuring that the data is up to date and accessible.	Severity Level: Medium – lack of communication from data owners may result in unexpected changes and diminished data integrity. The data owner is accountable for the use, quality and protection of a dataset.	2024	In progress
R1.2	Calculation Ownership	Assign owners of specific constants (e.g., PSPS risks) and calculation methodologies such that their definitions and approaches are agreed, documented and uniform across the business. This is to ensure that any colloquial terms used for aggregated data assets are consistent such that an output like “miles of span in HFTD in one group’s calculation is the same as another’s.	Severity Level: Low – a calculation owner will be accountable for ensuring calculation methodologies are clearly defined and are used appropriately and consistently.	2024	Not Started
R1.3	Model Ownership	Broaden model ownership in the form of a board or group with regular meeting cadence to agree to higher-level changes and adjustments, reviewing output of sensitivity analysis and changes prior to implementation. This would ensure that the responsibility for driving the direction of overall model enhancements is agreed upon amongst the Developers, Wildfire Mitigation team, and the Business users.	Severity Level: Low – without regular communication between all stakeholders, the direction and prioritization of model development and improvements can be missed.	2023	Complete
R1.4	Develop New Vegetation Risk Model	Development of a new Vegetation Risk Model, replacing the GIS Surveyors, Inc. (GSI) Tree Strike input, which is based on 2018 data. A sensitivity analysis should be performed to capture any changes.	Severity Level: Medium – development of a new vegetation risk model has the potential to change the ignition rate vegetation adjustment step, which will change the risk scores and may alter the mitigation rankings.	2023	Complete
R1.5	Refresh CHI	Replace/refresh the CHI input to incorporate updated data and ensure data components are not utilized more than once in the same calculations. A sensitivity analysis should be performed to capture any changes.	Severity Level: Medium – updating the CHI values will likely result in minor changes to the ignition rate asset health adjustment step which will change the risk scores slightly and may impact the mitigation rankings.	2024	Not Started

ID	Recommendation Name	Description	Severity Level and Impact	Target Deadline (EOY)	Status
R1.6	Update Data Input Check	Review the models and components utilized in WiNGS-Ops to validate whether an updated data input is available. This must be done while ensuring that the purpose and definition of the data is fully understood so any data assets or model inputs from WiNGS-Ops are complimentary to the existing WiNGS-Planning model.	Severity Level: Medium – updating constants will alter the final risk score results; however, the mitigation rankings may not change, or only change slightly.	2024	Not Started
R2.1	Model Value	In order to quantify the value the model brings to the business, define a measurable metric that clearly shows what benefit the model is providing in order to evaluate if the value offsets the costs. A potential metric could be tracking the percent Electric System Hardening (ESH) deviates from the model recommendations.	Severity Level: Low – while not directly affecting the model output, it is best practice to regularly evaluate the value a model brings to a business to determine future growth and investment.	2024	Not Started
R2.2	Initiation Stage Documentation	Document the initiation stage in order to capture critical elements of the initial planning stage. This includes defining what problem this model will solve, what is the feasibility of the model, who are the end users and how do they want to ingest the model outputs, who are the subject matter experts and what is their ability to participate in the model development, who will be the business owner of the model, what are the initial assumptions and how were they determined, and confirmation that all relevant business areas have taken full sponsorship of the project. Additional details on why certain decisions were made with respect to model generation are also critical to document in the initiation process.	Severity Level: Medium – due to the lack of documentation from the initiation of the WiNGS-Planning model, there are several assumptions and decisions that were made that cannot be explained now that the original stakeholders are no longer with the company.	2024	In progress
R3.1	Data Documentation and Dictionaries	Document for all input data, which should include the data owner, the context of the data, data collection methodology, structure and organization of the data, data validation and quality assurance steps, data manipulations from raw data, and data confidentiality, access and use conditions. If applicable, it should also include any calculations used to derive any of the fields, data dictionary of input data into those calculations, assumptions, references to methodologies or assumptions, and any limitations of the data. This will ensure a detailed understanding of the data that can be referenced as needed.  Additionally, develop data dictionaries for all input data, which should list all the data fields. Each data field listing should include a description, data type, acceptable numerical ranges or classification values if applicable, units, if mandatory, null or missing value definition, effective date, and update information (including date of update, by who, what was updated, and why). This will ensure a thorough understanding of each data field, as well as a reference for data validation steps.	Severity Level: Low – not having documentation or data dictionaries do not prevent the model from running, however, there is a risk of misunderstanding the data, or if there is turnover on the data science team, new team members will have a more challenging time referencing and understand the data inputs.	2024	In progress

ID	Recommendation Name	Description	Severity Level and Impact	Target Deadline (EOY)	Status
R3.2	Data Input Validation	Implement an automated data validation check for every data input to look for outliers, errors, text control, contradictions, etc. Each of these validation checks should have associated documentation that includes what to do when data is missing or anomalous. Examples of how outliers, errors, contradictions, etc. are detected and how corrections are performed in a demonstrable way should be provided if necessary.	Severity Level: Medium – there is currently a lot of reliance on source data owners to validate their data, which can lead to errors and reduce data quality.	2024	In progress
R3.3	Constants	Store constants used in the model calculations somewhere other than code itself. This will allow for better documentation of the assumptions that go into the constants decisions, and will result in ease of readability for review.	Severity Level: Low – this recommendation will not change any of the model outputs, however there is room to improve how to view the values, include all the proper documentation (see recommendation R2.1) and track changes (When it was changed, from what value, by who, and full reasoning for the change).	2023	Complete
R3.4	LiDAR Tree Data	Update tree locations based on available LiDAR data to present a more accurate count of strikes per mile input for the circuit segments.	Severity Level: Medium – updating tree locations will likely change the tree strike potentials for circuit segments.	2024	Not Started
R3.5	Shorter Than Conductor Height Trees Strike Buffer	Consider updating the tree strike model to address short trees that cannot hit the conductors based on the actual conductor height.	Severity Level: Medium – accounting for shorter trees that are not likely to fall into conductors may be over-represented in the risks currently captured.	2024	Complete
R3.6	CHI Update	Refresh or update the CHI input data, which was last refreshed in 2020, so it contains the most relevant data to provide the latest contribution to the modelling output.	Severity Level: Medium – updating the CHI values, will likely result in minor changes to the ignition rate asset health adjustment step and will probably have minimal impact on mitigation rankings.	2024	Not Started
R4.1	Derived Field Data Dictionaries	Add more detailed documentation to data dictionaries for each derived field that includes the calculation, data validation and quality assurance steps, data manipulations, null or missing value definition and/or handling, acceptable numerical ranges if applicable, effective date, and update information (including date of update, by who, what was updated, and why).	Severity Level: Low – Detailed documentation and data dictionaries are critical for ensuring an understanding of the generated data. Without them, there is a risk of misunderstanding the data or how to validate the results, particularly if there is turnover on the data science team. Having	2023	Complete

ID	Recommendation Name	Description	Severity Level and Impact	Target Deadline (EOY)	Status
R4.2	Derived Data Validation	In line with recommendation R3.2, incorporate data validation steps when new fields are derived to ensure the generated data is explainable, and include documentation that explains the validation steps taken and what to do when data is missing or anomalous. Provide examples of how flagged data is detected and how corrections are performed in a demonstratable way if necessary.	Severity Level: Medium – validating derived data is an important step for ensuring the most accurate model outputs. Some values are valid on their own which allows them to make it through the initial data ingest validation step, but when put in context with another value, it may indicate the data is an outlier.	2024	In progress
R4.3	Ignition Rate Veg Adjustment 0.001 Adder	Perform a detailed analysis of this step to confirm it is unnecessary, which will reduce the technical debt as well as reduce the amount of unnecessary documentation, especially when there is no explanation for this step.	Severity Level: Low – this step performs no function and therefore will not have any effect on the model results.	2023	Complete
R4.4	Mean Value Assessment	Conduct a detailed assessment of the instances where mean values are utilized in the calculations in order to determine if the approach would correctly account for outliers, potentially presenting a less risky situation than is accurate.	Severity Level: Medium – if it is determined that using mean values does not correctly account for outliers and a decision to use something other than mean values is made, then the data will change, which will result in a change to the risk score.	2025+	Not Started
R5.1	Stakeholder Involved Sensitivity Analysis	Conduct a more robust sensitivity analysis at a regular cadence (as outlined in ASTM E 1355 Section 10). Business stakeholders should be made aware of this sensitivity analysis and should be invited to participate in choosing the variables and their value ranges. The business users should then be involved in all output reviews and have the suggested changes/remediation actions presented to them, such that the impacts may be fully understood and agreed with.	Severity Level: Medium – a sensitivity analysis will provide the end users a better understanding of how different values affect the model as well as help identify which values are influencing the model the most. This will allow the end users to make more informed decisions when determining if they need to deviate from the model results.	2025	In progress
R5.2	Customer Type Multiplier Sensitivity Analysis	Perform a sensitivity analysis on the results of the customer type weight multipliers to evaluate if any unintended bias has resulted by adding weights to certain types of customers. This could include understanding the distribution of medical baseline and urgent customers relative to certain areas that may result in a decreased hardening priority.	Severity Level: Medium – if the results of the study indicate that the different customer type multipliers have the potential to adversely impact certain communities or demographics and the multiplier values are adjusted, that will result in changes to the CoRE model outputs and may change the mitigation rank for certain segments.	2025	Not Started

ID	Recommendation Name	Description	Severity Level and Impact	Target Deadline (EOY)	Status
R5.3	Formalize Model Validation Process	Devise and document formal process for validating the overall model outputs. This can be completed by comparing the run's results with previous iterations' outputs as well as identifying outputs that appear erroneous. It is also recommended to engage the end users to incorporate any additional thoughts or checks they have into the validation process.	Severity Level: Low – a formalized model validation process will instill greater trust by end users by knowing how the model results are validated prior to receiving the outputs, and can reference any generated validation reports.	2024	In progress
R5.4	Formalize External Feedback Management Process	Create formalized demand management process for external parties to provide feedback and request adjustments to the models. This will ensure that as the team, model, and user base continue to grow, there is a robust mechanism through which updates may be requested, tracked, and implemented in the Cloud environment.	Severity Level: Low – this will not directly affect the model outputs; however, this is an important validation step between model developers and end users to continue to facilitate model development, accuracy, and value to the business.	2025	Not Started
R6.1	Standardize Model Notifications	Create a standardized approach for how model update notifications are delivered and work with end users to capture the correct granularity and details that they would need to understand the changes.	Severity Level: Low – this recommendation will not have any effect on the model output, but ensures that the appropriate level of communication is delivered between the development team and the end users.	2025	In progress
R6.2	Docstring Best Practice	Ensure all python functions have docstrings, as older functions have not been updated. This will ensure that all functions are correctly documented, and definitions, descriptions, and decision point reasoning are captured. Docstring best practice for a function includes a brief description of what the function is and what it is used for, any arguments that are passed, labeling what is required and what is optional, any restrictions on when the function can be called, and/or any exceptions that are raised.	Severity Level: Low – this recommendation will not affect the model outputs, but is a best practice to follow when writing code.	2023	Complete
R6.3	Profiler	Run a profiler to identify any unused code that is taking up unnecessary technical debt.	Severity Level: Low – this recommendation does not affect the model output, but may improve the runtime performance of the model.	2025	In progress
R6.4	Unit Testing	Incorporate unit testing to ensure all functions are performing as expected.	Severity Level: Low – this recommendation will only affect the model if any functions are not performing as they should.	2024	In progress
R7.1	End User Data Consumption	Work with end user to see how they would like to consume the data, then develop and implement a standard way of delivering data.	Severity Level: Low – this recommendation has no effect on the model output results, but it is important to establish the most efficient way to deliver the output results to the end users.	2024	In progress



ID	Recommendation Name	Description	Severity Level and Impact	Target Deadline (EOY)	Status
R7.2	Aws Billing Limits	Introduce billing limits for certain sandbox/development activities such that there is not a risk of an unintended spike in cloud costs for a development error.	Severity Level: Low – this recommendation is to ensure that model costs are monitored and meet the set budget.	2025	Not Started
R7.3	Aws Access Control	Review access control principles, focused on two areas: <ul style="list-style-type: none"> <li>Review the default access periods, so access is revoked if someone doesn't access for a given period of time.</li> <li>Consider enabling row or column-level security to ensure users only access certain subsets of data most relevant and appropriate to them. This will become more needed in the WiNGS-Planning visualization tool.</li> </ul>	Severity Level: Low – following the security pillar from the 6 pillars of the AWS Well-Architected Framework will ensure the confidentiality and integrity of the data, and prevent unauthorized access and changes to the model and systems.	2025	Not Started
R7.4	Single Cloud Vendor Consolidation	In the future, consolidate services under one cloud provider for ease of use, integration, and billing. This can ensure that future updates to any of the cloud services are always made in a way to keep compatibility and seamless integration with the other developed components.	Severity Level: Low – this recommendation has no impact on the output of the WiNGS-Planning model, but would allow for greater efficiency in use of cloud services.	2025+	Not Started
R7.5	AWS Athena Consolidation	With improved Governance of the data, create only one instance of AWS Athena, with the GIS and Flat File data combined into the Data Mesh layer. With the data available in the Data Mesh, appropriate ownership and controls must be established such that any shared data is used within the bounds of its intended purpose.	Severity Level: Low – reducing from multiple instances of AWS Athena down to one would ensure efficiency of use and a lower overhead to manage, monitor, and maintain.	2025	In progress
R7.6	Go / No-Go	Engage with business users for a release of a new model version in the form of a Go/No-Go meeting such that the end users are engaged in the decision to approve a release and are made aware of any projected impact or change.	Severity Level: Medium – by performing a Go/No-Go meeting, there is assurance that the end-users understand and approve the newest model version. Without this assurance, the end users may not fully understand the latest model outputs, which could result in a misinterpretation of the model outputs.	2025	Complete
R7.7	Separate Access On AWS	Create separation in the access to Cloud workspaces as the products mature.	Severity Level: Low – this would allow more control over access control, budget planning, and spend tracking for the separate groups.	2025	Not Started

**Table 14: WiNGS-Ops Third Party Recommendations**

ID	Recommendation Name	Description	Severity Level	Target Deadline (EOY)	Status
R1.1	Model Approach Standardization	Expand standardization to all aspects of model development so that all models are tested and validated to the same specification. As most of the model build is independent, there is a potential lack of standardization for the development, training, testing and validations of models.	Severity Level: Low – without a standardized approach, each model may not hold the same level of credibility given varying levels of testing and validation. Standardization would improve consistency of model outputs.	2023	Complete
R1.2	Internal Model Review Process	Implement a level of peer-review to validate the scripts that are developed and operated. Creation of a more formalized internal model review process would provide a forum through which ideas may be discussed and considered before implementation, and through which a robust and consistent approach to model review may be performed.	Severity Level: Medium – this would enable potential improvements or ideas to be highlighted and discussed, leading to more effective and efficient models.	2023	Complete
R1.3	Model Documentation	Ensure documentation is complete for each of the latest model versions to be released for fire season 2023. As the team has been operating in a reactive state to changes in the WMP guidelines and recommendations, full documentation of each of the models is not complete and there is heavy reliance on the experience and knowledge of the individual team members.	Severity Level: Low – without robust model documentation, there is a reliance on the experience and memory of team members to explain the reasoning behind model decisions and changes.	2023	Complete
R1.4	Team Enhancements	Enhance the team with the addition of 1) a scrum master who can help generate and manage a backlog of tasks and activities such that activities may be prioritized, and a demand management process may be created and 2) a data analyst who could assist with external regulatory data requests, alleviating some of the time demands of the WiNGS-Ops Data Science team. The team consistently faces capacity constraints due to the ever-changing landscape of the WMP guidelines and recommendations, coupled with continued regulatory requests for data and information. As such, the team operates reactively to requests and priorities, without a true backlog of tasks captured and delivered against.	Severity Level: Medium – without changes to the team size and team roles, the full potential of members of the team may not be realized. Improved team size, capability, and demand management would allow for a more optimal environment, within which the greatest value may be generated.	2023	Complete
R1.5	Data Owner Communication	Ensure that there is an integrated function, such that communication from specific data owners is cohesive and timely. This would ensure the communication of definitions, use, bounds for validity, and decisions on potential changes. Data owners would also be responsible for ensuring that the data is up to date and accessible.	Severity Level: Medium – lack of communication from data owners may result in unexpected changes and diminished data integrity.	2024	In Progress

ID	Recommendation Name	Description	Severity Level	Target Deadline (EOY)	Status
R1.6	Calculation Ownership	Assign owners of specific constants (e.g., PSPS risks) and calculation methodologies such that their definitions and approaches are agreed, documented and uniform across the business. This is to ensure that any colloquial terms used for aggregated data assets are consistent such that an output like “miles of span in HFTD in one group’s calculation is the same as another’s.	Severity Level: Low – a calculation owner will be accountable for ensuring calculation methodologies are clearly defined and are used appropriately and consistently.	2024	In Progress
R1.7	Model Ownership	Implement broader model ownership in the form of a board/ group with regular meeting cadence to agree to higher-level changes and adjustments, reviewing output of sensitivity analysis and changes prior to implementation. This would ensure that the direction of overall model enhancements and improvements is agreed amongst the Developers, Wildfire Mitigation team, and the Business users.	Severity Level: Low – without regular communication between all stakeholders, the direction and prioritization of model development and improvements can be missed.	2025	In Progress
R1.8	EAMP Data Experts	Onboard an internal team to share subject matter expertise responsibility for EAMP/Asset 360. EAMP/Asset 360 provides a rich asset data source used in modeling. The data itself is a clean and curated version of GIS and Asset Management data. Currently, the program is operated by external contractors who also remain as the data source subject matter experts. The source, including all dictionaries and implemented manipulations, should also be fully documented such that any new user may easily gain a complete understanding of the data and its use.	Severity Level: Medium – with a continued reliance on external parties for this critical data source, the team will not gain full ownership, understanding, and control over the underlying data. Internal subject matter expertise in the data source will ensure a robust and future-proof mechanism for data understanding, questions, and data updates.	2025	In Progress
R1.9	External Inference Team	Integrate more SDG&E resources into the inference team so that knowledge and experience is internalized and reliance on external contractors is reduced. Currently, the development team responsible for the inference aspects of WiNGS-Ops are a group of external contractors. The team is effective in the conversion of models from training and test phase to inference phase but do not look to challenge the training team to improve the models.	Severity Level: Low – as the WiNGS-Ops model continues to mature and gain complexity, the technical debt on external development members of the Advanced Analytics team will grow, increasing this reliance.	2025	In Progress
R2.1	OIR Requirements	Build and maintain a formalized report that tracks OIR requirements and how they were carried out in order to ensure that all Order Instituting Rulemaking (OIR) requirements are met and prevent possible violations. Having this existing documentation will not only confirm what the requirements are and if and how they were completed but will also be ready to pass along to the OIR as appropriate.	Severity Level: Low – this will help prevent potential violations from the OIR by tracking all the requirements and how they were completed.	2024	In Progress

ID	Recommendation Name	Description	Severity Level	Target Deadline (EOY)	Status
R2.2	Model Change Documentation	Create a formal process through which requirements for model changes are captured, tracked, and completed against. This will ensure that changes are understood and captured correctly and will allow success criteria to be defined and assessed against by the end users in their approval of model changes.	Severity Level: Low – without a documented process, requirements and requested changes may be incorrectly implemented or the end users may not have an easy mechanism for change approval.	2024	In Progress
R2.3	Model Value	Establish metric(s) to gauge the effectiveness of the model, which will help determine the value the model is bringing to the business. This will ensure that the impact of model improvements and developments over time are quantified and tracked.	Severity Level: Low – this recommendation will increase end user buy in and understanding of the changes that are enacted in the model.	2023	Complete
R2.4	Initiation Stage Documentation	Document the initiation stage in order to capture critical elements of the initial planning stage. This includes defining what problem this model will solve, what is the feasibility of the model, who are the end users and how do they want to ingest the model outputs, who are the subject matter experts and what is their ability to participate in the model development, who will be the business owner of the model, what are the initial assumptions and how were they determined, and confirmation that all relevant business areas have taken full sponsorship of the project. Additional details on why certain decisions were made with respect to model generation are also critical to document in the initiation process.	Severity Level: Low – without this documentation in place, future developers and end users may have a more difficult time understanding the decisions and assumptions that were made, which subject matter experts to turn to for input, how the model will be measured for success, or the original problem and objectives.	2024	In Progress
R3.1	Data Input Validation	Implement an automated data validation check for every data input to look for outliers, errors, text control, contradictions, etc. Each of these validation checks should have associated documentation that includes what to do when data is missing or anomalous. This should be implemented in the inference pipeline and should be consistent with data validation performed by the WiNGS-Ops data science team during their exploratory data analysis process.	Severity Level: Medium – there is currently a lot of reliance on source data owners to validate their data, which can lead to errors and reduce data quality.	2024	In Progress
R3.2	Pole and Span Imputation	In collaboration with the GIS team, develop a logic-based solution for imputing pole location information using other fields when historical pole locations are missing. This may include utilizing an existing GIS redlining process for resolving these gaps.	Severity Level: Low – this would ensure that the data used in modeling is most representative of the network. It may also help reduce the number of minority class records that are dropped due to missing data.	2025	In Progress

ID	Recommendation Name	Description	Severity Level	Target Deadline (EOY)	Status
R3.3	Network As Switched Limitation	Note this as a limitation of the model and prior to PSPS activations that the systems are restored to the as-designed states wherever possible. In addition, contact Operations personnel to confirm the correct owner of the network as-operated electrical connectivity data since this data is a critical component of the WiNGS-Ops model. Seeking out information on the root data source, how it is validated, and the existing assumptions are critical for ensuring a complete understanding of the data and its correct use.	Severity Level: Low – without knowing the correct data owner or who to reach out to with concerns or data issues, there will be continued uncertainty of the data and of the stewardship and accountability surrounding that data.	2023	Complete
R3.4	Data Object Governance	Increase governance and controls for each of the data objects utilized by WiNGS-Ops such that none of the data created for and used in the models is inadvertently used for a different purpose, generating alternative and incorrect views of the landscape.	Severity Level: Low – although this may not directly impact the output of the WiNGS-Ops model, it may affect the credibility of the data sources used if the source is used incorrectly elsewhere.	2024	In Progress
R3.5	SAIDIDAT Data Ingestion	Perform a direct query of SAIDIDAT data from its source database. This eliminates the reliance on individuals and prevents potential human error.	Severity Level: Low – manual data request and transfers are reliant on the requestor to ask for the information. Automating the request process may be a better way to obtain updated outage history data on a scheduled basis rather than on an as-requested basis.	2024	In Progress
R4.1	Feature Removal	For the models that do not have auto regularization, remove the less relevant features as measured by the feature importance function outputs. Removing less relevant features will help with the stability of the model, avoid overfitting, and reduce computation cost.	Severity Level: Medium – it is unclear at this stage the impact that inclusion of these unimportant features has on the outputs. Removing them has the potential to skew results which may have a large impact, so has been rated as such.	2024	In Progress
R4.2	Alternative Land Use Data Source	Work closely with the SANGIS team to incorporate service territory areas currently not covered in their existing coverage data, as well as request more frequent than annual data updates. This would ensure the models have access to the same information as the rest of San Diego County and are up to date during a red flag warning event.	Severity Level: Low – models run on data which has not been recently refreshed or on imputed data based on mean values may provide inaccurate outputs. This may cause a model to under-represent the potential consequence of an ignition due to a missing at-risk land use.	2024	Not Started

ID	Recommendation Name	Description	Severity Level	Target Deadline (EOY)	Status
R4.3	Model Improvement Limitations	Do not develop or incorporate additional features to the models. Due to the time pressures and resource constraints, the team does not have the capacity to further improve models in this manner.	Severity Level: Low – impact would be minimal due to the models’ existing satisfactory performance but might represent a missed opportunity for continued model improvements and enhancement.	2024	In Progress
R4.4	Safety Weights Documentation	Create a documented framework to define the safety weights used in the PSPS model such that there is an explainable process through which they may be assessed and updated based on additional subject matter expertise. These weights must also be integrated into version control, so that changes are managed and easily tracked, model version to model version. This documentation would help future model developers and users better understand why certain values were used and what the historical justifications and rationale were.	Severity Level: Low – without a clearly documented process for suggesting changes to the weights and version control to track those changes, it may be difficult to provide explanatory evidence in support of decisions driven by this model.	2024	Not Started
R5.1	Class Imbalance Approaches	Test other approaches to handling class imbalanced data, including up-sampling, SMOTE, and ADASYN, in order to determine the most applicable method for each model.	Severity Level: Medium – down-sampling excludes significant amounts of data which may result in an unrepresentative data sample being used for training and testing the model.	2024	In Progress
R5.2	Algorithm Testing	Test other algorithms to ensure that the most suitable algorithm is used to solve the problem, balancing complexity of understanding and training with accuracy of modeling outputs.	Severity Level: Low – without validating that there isn’t a more suitable algorithm for the model, the team cannot be certain that they have built the most suitable model for the specific application.	2024	In Progress
R5.3	Collaborative Model Development and Release	Implement a more collaborative approach towards model development and release. A peer-reviewed approval process (similar to the one used by WiNGS-Planning) can ensure consistency between sub-models and that best practices are followed.	Severity Level: Medium – individual working may lead to inconsistencies between models, resulting in deployment of models with differing levels of robustness.	2025	In Progress
R5.4	Conductor Model Retrain	Retrain the conductor model based on data from 2015 to present, utilizing the 2022 data for testing and validation. This will ensure the most representative data is utilized in construction and training to create the most accurate and useful modeling outputs.	Severity Level: Medium – based on the most recent data used for validation, the model under-represented the potential risk due to conductor failure. Re-training this model would generate a more representative output.	2024	In Progress

ID	Recommendation Name	Description	Severity Level	Target Deadline (EOY)	Status
R5.5	Same Data Sources	Train the models on the same data sources that would be utilized for inference in production such that the resulting outputs are most relevant and applicable.	Severity Level: Medium – as the models were trained on different source data, the learned data relationships may not be representative of what would be seen in the EOC. As a result, outputs of the models may not be as accurate as if the data used for training was the same source as used in inference.	2024	In Progress
R5.6	GIS Cleaning	Consider a larger program of GIS data cleaning, validating, and improvement and investigate if existing GIS red lining processes can be leveraged to ensure the GIS system of record for assets represents the most accurate view of assets in the service territory. This would ensure that any modeling application or activation event would consider that most accurate understanding when making data-driven decisions.	Severity Level: Low – it is critical that decisions in the EOC are made based upon the most accurate representation of the assets in the field.	2025	Not Started
R5.7	Hyper-parameter Tuning	Implement the approach used for tuning hyper-parameters in the foreign object model, GridSearchCV, for tuning hyper-parameters in the vehicle contact model.	Severity Level: Low – consistent use of techniques across models ensures that the quality and robustness of each model is uniform and contributes to an optimal output.	2024	Not Started
R5.8	SHAP	Incorporate Shapley Additive Explanations (SHAP) to help explain model outputs through calculating the contribution of each feature to the model output. These values can be used to understand the importance of each feature and to explain the results of the model.	Severity Level: Low – without a full understanding of the importance and contribution of the features in a model, the driving factors of the model's outputs are less explainable.	2023	Complete
R6.1	Brier Score	Use the full Brier score such that the outputs are unaffected by population size. This will enable Brier scores to be compared across different versions of a model to allow model improvements to be validated.	Severity Level: Low – a modified Brier score might be inadvertently used to compare models with different sample sizes. This would give an inaccurate view of the performance comparison and could result in an incorrect modeling decision.	2025	Not Started

ID	Recommendation Name	Description	Severity Level	Target Deadline (EOY)	Status
R6.2	Class Imbalance Validation Methodology	For the vehicle contact model, incorporate a nested cross validation where one fold is an out-of-period imbalanced data split for the final validation and the other fold is split for training and testing on balanced sampled data set. This would provide an additional method for validating the accuracy of the model. Ensure the right metric is used for the evaluation, as some metrics are better for evaluation when there is class balance (ROC AUC) and others are better for when there is class imbalance (Precision-Recall AUC).	Severity Level: Medium – validating imbalanced data with this approach checks performance of the model against real class distribution.	2025	Not Started
R6.3	Uniform Model Testing	Establish a consistent and agreed approach for model testing across the team such that each member may be sure of the optimal model and be in agreement when training is complete. This will ensure consistency across models and build credibility with the end users.	Severity Level: Low – models may have differing levels of robustness without a uniform, defined, and agreed upon approach to testing.	2024	In Progress
R6.4	Data Documentation	Provide detailed documentation for all data that is ingested into the models. The documentation is the responsibility of the data owners and should contain pertinent information such as the data owner, data collection methodology, data dictionary, structure of the data, data validation and quality assurance steps taken, data manipulations from the raw data, and confidentiality, access and use conditions. This will ensure a detailed understanding of the data that can be reference as needed, critical for ground truth data.	Severity Level: Low – without detailed documentation, there is a risk the data can be misinterpreted, or if there is turnover or new hires on the WiNGS-Ops Data Science or Advanced Analytics teams, they may have a more challenging time referencing and understanding the data inputs.	2024	In Progress
R7.1	Back-casting Model Validation Process	Create a more holistic and reliable model validation process to allow automated back-casting for each model change. This would allow for greater confidence in the updated version of each model. Given the snapshots of data are now maintained in the cloud, this ensures that this process would be simpler to perform.	Severity Level: Low – without an automated and uniform approach to model output validation, validating each new model release will be a time-consuming and inconsistent process.	2024	In Progress
R7.2	Back-casting Data Capture	Ensure that all necessary data and calculation components are captured, including the network configuration, at the time of a PSPS activation to help streamline future back-casting exercises.	Severity Level: Low – implementing this would allow for the automated and uniform approach mentioned in R7.1 and could be enacted for model back-casting.	2025	In Progress
R7.3	End User Formalized Validation Process	Establish a formalized validation process by the end users that will establish consistency in the validation approach and also build credibility with OEIS by demonstrating the results are reviewed in a specific and systematic way.	Severity Level: Low – without a formalized validation process, there is the potential for end users to validate the model differently every time a new model version is released. This may result in missing an important check, or reviewing an output that differs from a previous model version.	2024	In Progress



ID	Recommendation Name	Description	Severity Level	Target Deadline (EOY)	Status
R8.1	Centralize Models	Migrate the conductor training model and PSPS model scripts to Azure DevOps Repos. This will ensure development on local machines are version controlled, tracked appropriately, and accessible by the team. This will also allow models to leverage cloud compute capabilities, meaning that more advanced models may be produced. Additionally, the PSPS model should be passed to the inference team such that the entire WiNGS-Ops model can be executed through the inference pipeline.	Severity Level: Medium – current processes limiting version control and access could introduce errors and confusion in the correct version that should be run in production. Full cloud migration would limit the risk of this issue.	2025	In Progress
R8.2	Model Training Process Explanation	The model training team should provide a more thorough explanation of the model training process and decisions which would enable the Advanced Analytics team to have a better grounding for implementing the code. As well as education sessions, thorough documentation would enable any new team members to be onboarded swiftly.	Severity Level: Low – without full understanding and knowledge of the model training process, the Advanced Analytics team may not be able to add as much value in critiquing and improving the models.	2023	Complete
R8.3	Combine Pole and Span Ignition Models	Combine the pole and span ignition models to remove any overlaps which might exist.	Severity Level: Medium – currently the models are not fully independent, which may skew the results. This should be rectified such that an accurate representation of risk may be generated.	2024	In Progress
R8.4	Profiler	Run a profiler to help understand the resource consumption of the various operations in the model. This can potentially resolve performance bottlenecks and help the model execute faster.	Severity Level: Low – this recommendation does not affect the model output but may improve the runtime performance of the model.	2025	In Progress
R8.5	Unit Testing	Incorporate unit testing to ensure all functions are performing as intended and errors are more easily isolated when they occur. Unit tests also check that the code still functions as expected after making changes, which builds code stability.	Severity Level: Medium – Without unit testing, there is no assurance that the code will function correctly and that there are no undiscovered bugs. This can lead to poor quality modeling results and wasted time and resources spent debugging.	2025	In Progress
R8.6	Integration Testing	Incorporate integration testing to ensure all functions and scripts are working together as intended and there are no conflicts or errors between different code units.	Severity Level: Medium – without integration testing, there is no assurance that all functions and scripts are working together correctly. In addition, the team will be less efficient at debugging and will spend time and resources fixing errors.	2023	Complete

ID	Recommendation Name	Description	Severity Level	Target Deadline (EOY)	Status
R8.7	Docstrings	Ensure all python functions have docstrings, which will ensure that all functions are correctly documented and definitions, descriptions, and decision point reasoning are captured. Docstring best practice for a function includes a brief description of what the function is and what it is used for, any arguments that are passed, labeling what is required and what is optional, and determining any restrictions on when the function can be called or any exceptions that are raised.	Severity Level: Low – this recommendation will not affect the model outputs, but is a best practice to follow when writing code.	2025	In Progress
R9.1	Internal Resources Embedded into Each Team	Ensure there is a skilled and knowledgeable base of internal resources involved in each aspect of the WiNGS-Ops modeling process such that reliance on external parties is reduced.	Severity Level: Low – the Advanced Analytics team is skilled and knowledgeable so there is minimal risk to the model outputs at this stage.	2025	In Progress
R9.2	Cloud Consolidation	Consolidate services under one cloud provider for ease of use, integration, and billing. This can ensure that future updates to any of the cloud services are always made in a way to keep compatibility and seamless integration with the other developed components.	Severity Level: Low – this recommendation has no impact on the output of the WiNGS-Ops model but would allow for greater efficiency in use of cloud services. Although cloud services may work together across different vendors, they are optimized to work most effectively when combined with services belonging to one single cloud provider.	2025	Not Started
R9.3	Pipeline Deployment Documentation	Create robust and granular documentation of the deployment pipeline, which would ensure a lower reliance on the experience of resources.	Severity Level: Medium – without this documentation, a continued reliance on external resources would be mandatory as there would be no straightforward mechanism through which internal resources could inform themselves on the finer details of the inference pipeline.	2025	In Progress
R9.4	Modeling Key Drivers	Expose key drivers of the modeling output to the users, such that they may gain a greater understanding of the outputs and some indication on how an output should be viewed and utilized.	Severity Level: Low – this detail may allow for greater understanding and trust in the WiNGS-Ops output.	2025	In Progress
R9.5	Limitations Documentations	Document the limitations of the models that underpin the WiNGS-Ops outputs and ensure that these are fully understood by the business users. This will ensure that any decisions made based on the result of the WiNGS-Ops model are made from the most informed position.	Severity Level: Medium – without understanding the limitations of the model, sub-optimal decisions may be made due to a misinterpretation of the results.	2024	In Progress

ID	Recommendation Name	Description	Severity Level	Target Deadline (EOY)	Status
R9.6	Full Model Lifecycle Documentation	Document the full lifecycle of each model in training and in inference such that the knowledge, skills and experience of the team is captured for future use. This would also enable training and onboarding of new resources to be more straightforward and regulatory filings to be completed more swiftly. Example pieces to include in this documentation are the problem formulation process, all decision points and reasonings, and future plans and intentions.	Severity Level: Low – the team is knowledgeable in the models they have constructed so any risk is reduced. In most cases there is only one team member with discrete knowledge of the specific model.	2025	In Progress
R9.7	Weather Sanitization Ownership Update	Update the technical ownership of the weather sanitization repository and any other repositories that may have changed ownership.	Severity Level: Medium – the script is well understood by multiple parties, however there is no single owner to drive decisions or improvements.	2024	In Progress
R9.8	Weather Station Imputation Mapping	On the inference side, implement the device to weather station associations that the Meteorology team determined based on topographical features into the weather station mapping. This will ensure the most suitable weather station data is used for each segment.	Severity Level: Medium – there is the potential to produce skewed results if there is a significant topographical impact on certain spans.	2024	In Progress
R9.9	Missing Data Outputs	Correct data issues such that all segments have an outputted value from the WiNGS-Ops model. Failing that, provide full communication and explanation to the end users for those segments where a WiNGS-Ops output was unable to be generated. This would ensure that awareness of these missing values is gained and decisions are not based on the omission of those segments in the model outputs.	Severity Level: Medium – while the PSPS de-energization decision takes other inputs aside from WiNGS-Ops, without a complete model output for every segment, it is conceivable that the decision maker will lose trust with WiNGS-Ops model if a PSPS de-energization decision would need to be made for a segment that has no WiNGS-Ops output.	2024	In Progress
R9.10	Cold Storage	Consider the use of cold storage for long-term storage of snapshots or model runs which do not need to be accessed regularly. This would reduce the overall costs of the cloud infrastructure, which will become more important as the models and data sets mature and grow in size.	Severity Level: Low – as the size of files being stored currently is not large, use of cold storage would have a minimal effect on the cost of cloud services, though remains a best practice recommendation.	2025	Not Started
R9.11	Error Monitoring Dashboard	Develop a monitoring dashboard that provides real-time error monitoring and a view of the model runs such that issues may be highlighted and resolved in a timely manner.	Severity Level: Low – existing monitoring allow for errors to be identified; however, advanced monitoring would allow a more streamlined process for error identification and remediation.	2024	In Progress

ID	Recommendation Name	Description	Severity Level	Target Deadline (EOY)	Status
R9.12	Global ID Cleaning	Clean the data such that all Global IDs are valid and the amount of feeders without output results due to invalid global IDs decreases. This will prevent situations where the WiNGS-Ops model is unable to produce risk scores.	Severity Level: Medium – having up to 10% of feeders without risk scores could cause a loss of credibility within the organization when the model is needed to provide data driven insights for PSPS de-energization decision making.	2024	In Progress
R9.13	WiNGS-Ops Support Position	Create a new role in the EOC to provide WiNGS-Ops model support. This person would be knowledgeable about all aspects of the model, outputs, limitations, and the impact on other components utilized in EOC decision-making.	Severity Level: Low – without this role in the EOC, the model may not be fully understood so model outputs may be interpreted incorrectly. This could lead to sub-optimal decisions being made.	2023	Complete
R10.1	Issue Reporting Process	Create a formalized process for issue reporting from the end users to the development teams. This should be simple and streamlined such that any issues may be raised, quantified, and remediated quickly.	Severity Level: Low – currently there is no prescribed process, which could lead to confusion as to the point of escalation for issues. This may result in a delay to any remediation activity and impact the quality of outputs.	2024	In Progress
R10.2	Action & Tasks Log	Document meetings and create a backlog for actions/tasks so they can be prioritized, tracked, and completed against. This will ensure that all tasks are captured and implemented as intended and miscommunication is avoided.	Severity Level: Low – without a formalized process of documentation and action tracking, there may be more instances of misunderstanding of intention between teams, which might result in a sub-optimal outcome or re-work in remediating the concern.	2025	In Progress
R10.3	Questions and Model Changes Tracking	Create a formalized process for questions and model changes ahead of each activation event. In addition, track changes to model code and outputs through formal version control. This will mean that the decision points and actions taken are formally documented and easily explainable if a reference is required, which may aid answering regulatory questions or post-event report preparation.	Severity Level: Low – the current process will result in a more time-consuming post-activation event reporting process. This may mean a period of potential re-work to establish the reasoning behind certain tweaks and decisions taken in the model pre-event.	2025	In Progress
R10.4	WiNGS-Ops Overall Versioning Process	Create an overall WiNGS-Ops model versioning process such that changes or updates to any component of WiNGS-Ops results in a version iteration. This ensures that users have a clear indication of when a model methodology has changed. This may help the users understand which models may be easily compared.	Severity Level: Low – the current versioning methodology may result in inaccurate comparisons being made by end users across models.	2025	In Progress

## 5.7 SDGE-23-08: Continuation of Grid Hardening Joint Studies

---

### Description

The utilities have jointly made progress addressing the continued Joint IOU Covered Conductor Working Group area for continued improvement (SDGE-22-11 and SDGE-22-13). Energy Safety expects the utilities to continue these efforts and meet the requirements of this ongoing area for continued improvement.

Discussed in Section 8.1, “Grid Design, Operations, and Maintenance” (8.1.2 “Grid Design and System Hardening”).

### Required Progress

In its 2025 Update, SDG&E, along with all other IOUs (not including independent transmission operators), must continue the relevant studies and meetings and report on the progress and outcomes of these studies and meetings in the Joint IOU Covered Conductor Working Group Report. This must include:

- Progress made on any next steps included in the report.
- A description of any lessons learned SDG&E has applied to its WMP, including a list of applicable changes and a timeline for expected implementation.
- A summary of any completed workshops, including a list of topics and dates, and takeaways.
- A list of additional workshops and proposed dates.

Additionally, SDG&E must continue to collaborate with other utilities on efforts relating to grid hardening. In its 2026-2028 Base WMP, SDG&E, along with other utilities, must submit a report which discusses continued efforts including:

- The IOUs’ joint evaluation of the effectiveness of undergrounding. This must account for any remaining risk from secondary or service lines, analysis on in-field observations from potential failure points of underground equipment, and ignition risk as well as PSPS risk.
- The IOUs’ joint lessons learned on undergrounding applications. This must include use of resources to accommodate undergrounding programs, any new technologies being applied to undergrounding, and cost or deployment maximization efforts being used.
- The IOUs’ joint evaluation of various approaches to implementation of protective equipment and device settings. This must include analysis of the effectiveness of various settings, lessons learned on how to minimize reliability and associated safety impacts (including use of downed conductor detection and partial voltage detection devices), variations on settings being used including thresholds of enablement, and equipment types in which such settings are being adjusted.
- The IOUs’ continued efforts to evaluate new technologies being piloted and deployed. This must include, but not be limited to: REFCL, EFD, DFA, falling conductor protection, use of smart meter data, open phase detection, remote grids, and microgrids.

- The IOUs’ joint evaluation of the effectiveness of mitigations in combination with one another, including, but not limited to: overhead system hardening, maintenance and replacement, and situational awareness mitigations.

## **SDG&E Response**

### **5.7.1 Joint IOU Covered Conductor Working Group Report**

#### **Introduction**

In the 2021 WMP Update Final Action Statements, Energy Safety ordered the Joint IOUs<sup>19</sup> to coordinate to develop a consistent approach to evaluating the long-term risk reduction and cost-effectiveness of covered conductor (CC) deployment, including 1) the effectiveness of CC in the field in comparison to alternative initiatives and 2) how CC installation compares to other initiatives in its potential to reduce PSPS risk. The utilities formed a Joint IOU Covered Conductor Working Group and developed an approach and preliminary milestones to enable the utilities’ to better discern the long-term risk reduction effectiveness of CC to reduce the probability of ignition, assess its effectiveness compared to alternative initiatives, and assess its potential to reduce PSPS risk in comparison to other initiatives. The approach consisted of multiple workstreams including:

- Benchmarking
- Testing
- Estimated Effectiveness
- Recorded Effectiveness
- Alternatives Comparison
- Potential to Reduce PSPS Risk; and
- Costs

In the 2022 WMP Update filings and subsequently in the 2023-2025 WMP, the utilities produced a joint report that provided an update on their progress for each of the workstreams, added efforts, and preliminary plans for 2023.

In the 2022 WMP Update Final Decisions, Energy Safety identified Areas of Continued Improvement and Required Progress (ACI) for all utilities to expand this working group to include:

1. Joint CC Lessons Learned
2. CC Maintenance and Inspection (M&I) Practices; and
3. New Technologies Implementation

Given these directions, the utilities expanded the Joint IOU Covered Conductor Working Group to include ten workstreams and began meeting on the new workstreams in Q3/Q4 2022. Below is the summary of process made in 2023 to address the commitments identified in the report.

#### **Overview**

In 2023, the utilities conducted workshops across the various workstreams. New workstreams evaluated CC M&I best practices, assess data and information on effectiveness of new technologies and shared

<sup>19</sup> In this progress report, “Joint IOUs,” “IOUs,” or “utilities” refers to SDG&E, PG&E, SCE, PacifiCorp, BVES, and Liberty.

practices and implementation strategies, and review studies on CC's ability to reduce PSPS impacts. The utilities continued to further benchmark efforts, improve methods for estimating and measuring effectiveness, and continue to track and compare unit costs. Below, the utilities describe the progress made on each workstream.

## **Testing**

In our 2023-2025 WMPs, the utilities committed to conducting meetings and workshops to assess the testing results, determine if any additional tests are needed, and determine if any mitigations are warranted such as changes to materials, construction methods, or inspection practices. The Joint IOUs held bi-weekly meetings to review testing results. In addition, workshops were held with Energy Safety to discuss the following topics relating to testing:

- May 2023 – Corrosion Testing;
- June 2023– Aging Susceptibility testing; and
- July 2023 - Status of IOUs remaining testing results

Corrosion testing resulted in minor aluminum degradation below the covering following the corrosion testing, though copper CC had similar performance as the exposed bare conductor. SCE continues to inspect in-service installations of CC for monitoring the applied performance of the conductor. As a result of the discussions and outcome of the supplemental testing results, the Joint IOUs concluded that no additional testing was warranted at this time. All results have been submitted to OEIS. The Joint IOUs have concluded this workstream.

PG&E has incorporated the lessons learned from the testing results in 2024 update to PG&E's Overhead Assessment Inspection Job Aid TD-2305M-JA02, as described in response to ACI PG&E-23-08. Furthermore, please also see responses to ACI PG&E-23-08 for PG&E's planned evaluation of additional conductor types to mitigate water intrusion. This effort will be conducted outside of the Joint IOU efforts.

## **Recorded and Estimated Effectiveness**

The joint IOUs have met monthly in 2023 to discuss the results of recorded and estimated effectiveness for covered conductor. These discussions have demonstrated that while there is a need to align consistent methods, based on the individual constraints each utility faces, some of the drivers and data will ultimately be different. The Joint IOUs will continue to compare risk drivers, the results of recorded and estimated effectiveness, identify current alignment and opportunities for alignment and understand differences.

## **Alternatives, New Technology, Benchmarking and PSPS Practices**

The team decided to combine the alternatives, benchmarking, PSPS practices and new technologies workstreams. The team met bi-weekly to discuss the various technologies being considered and/or adopted by each Joint IOU, shared lessons learned, and discussed if these new technologies had any impact on PSPS practices. As a workstream the team identified questions on some of the new technologies for benchmarking. The team is finalizing the questions and plan to complete the benchmarking survey in 2024.

The Joint IOUs held three workshops with OEIS to discuss these workstreams:

- June 2023 – Distribution Fault Anticipation (DFA) – Discuss implementation strategies, practices and effectiveness
- July 2023 – Early Fault Detection (EFD) – Discuss implementation strategies, practices and effectiveness
- August 2023 – Rapid Earth Fault Current Limited (REFCL) – Discuss implementation strategies, practices and effectiveness

During the workshops the Joint IOUs shared how each utility was using the technology, the current status of implementation, and impacts to PSPS practices. No additional technology is being considered, therefore this workstream has concluded.

### **M&I Practices**

In 2023, the utilities met monthly to discuss utility specific general and CC M&I practices and presented the materials in a workshop with Energy Safety on July 24, 2023. At the conclusion of the workshop, it was determined that no additional workshops were necessary.

For SCE, please see the response to ACI SCE-23-11, regarding CC inspection and maintenance.

In 2023, PG&E worked on the update of the Electric Distribution Overhead inspection Job Aid and in December released the updated Job Aid TD-2305M-JA02 that includes additional guidance for the inspection of Covered Conductor.

### **Costs**

In 2023, the utilities discussed the unit costs of CC and undergrounding and compared at a high level the different cost drivers. This discussion better informed the utilities of the differences behind the unit costs. The utilities meet regularly and will continue to share as information changes and costs are better defined with more installation.

### **Conclusion**

All of the utilities met regularly on all workstreams in 2023 and addressed all of the commitments identified in the 2023-2025 Joint IOU Covered Conductor Effectiveness Report. In addition, all of the utilities developed standing monthly Joint IOU meetings, which created a forum to share updates on wildfire topics and to stay updated on key developments. The utilities also developed an undergrounding working group to discuss challenges with undergrounding and related lessons learned. These forums will allow the joint utilities to continue data sharing and knowledge transfer on important wildfire mitigation topics.

## **5.7.2 SDG&E Response**

SDG&E leveraged information obtained while participating in the joint IOU working groups to update its understanding of the efficacy of covered conductor installation (WMP.455) and covered conductor installation combined with FCP (WMP.463) and EFD (WMP.1195).



## Covered Conductor Efficacy

In the 2023-2025 Wildfire Mitigation Plan, ignition driver efficacy and ignition data were used to calculate the estimated effectiveness of covered conductor. However, this approach did not align with the calculation of the effectiveness of other initiatives or with how other large IOUs utilize risk event data for effectiveness calculations. In 2023, calculations were updated to include risk event data, which utilizes a much larger data set (over 2,000 events) than ignitions (60 events). Outputs of covered conductor testing and benchmarking with the other IOUs were also utilized to update the effectiveness of covered conductor installation to prevent common risk event drivers. These risk event drivers and the associated effectiveness value for covered conductor installations are shown in Table 15.

**Table 15: Efficacy of Covered Conductor**

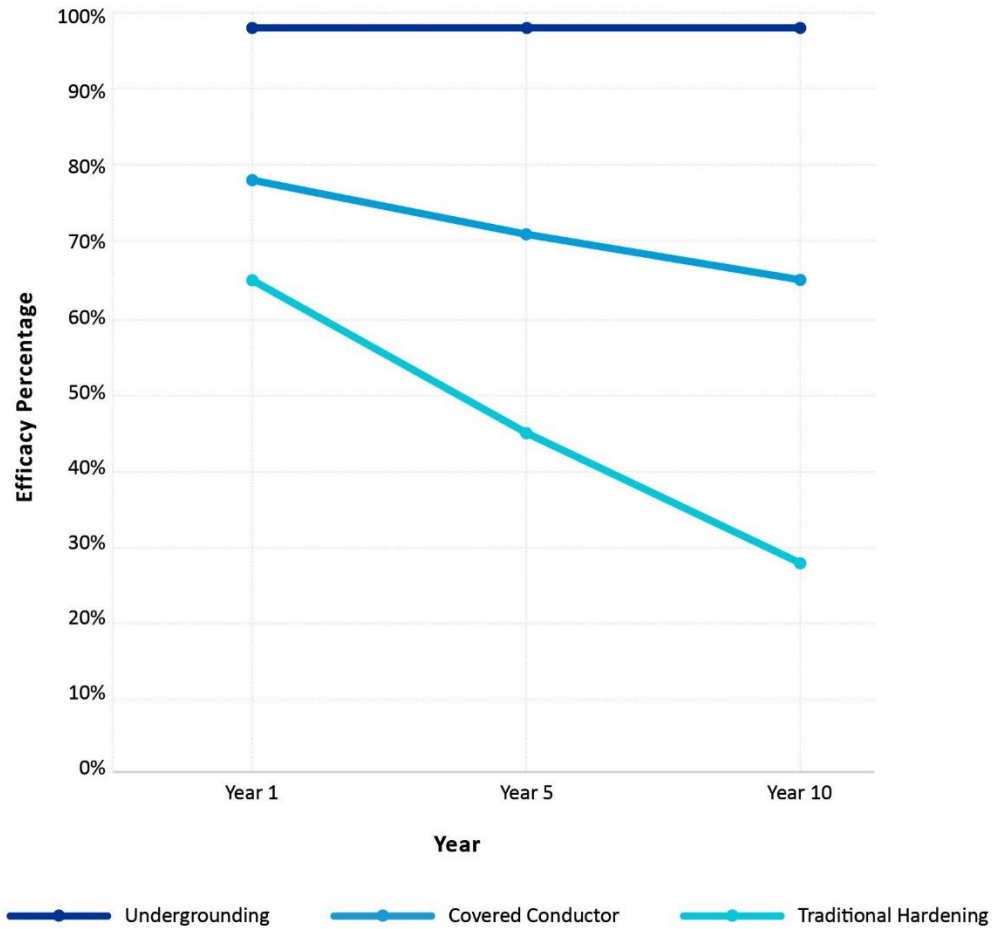
Risk Event Driver	2023 Efficacy of Covered Conductor	2024 Efficacy of Covered Conductor
Animal contact	90%	90%
Balloon contact	90%	90%
Vegetation contact	90%	90%
Vehicle contact	20%	80%
Crossarm damage or failure	30%	30%
Conductor damage or failure	90%	90%
Other - contact	10%	50%
Insulator and bushing damage or failure	80%	30%
Other - equipment failure	80%	30%
Capacitor bank damage or failure	80%	30%
Fuse damage or failure	80%	30%
Lightning arrester damage or failure	80%	30%
Switch damage or failure	80%	30%
Pole damage or failure	80%	30%
Voltage regulator damage or failure	80%	30%
Recloser damage or failure	80%	30%
Anchor/guy damage or failure	80%	30%
Sectionalizer damage or failure	80%	30%
Connection device damage or failure	80%	30%
Transformer damage or failure	80%	30%
Wire-to-wire contact	99%	99%
Contamination	80%	80%
Utility Work	90%	90%
Vandalism/Theft	10%	10%
Other - All (includes wire-down & fire)	10%	10%

Risk Event Driver	2023 Efficacy of Covered Conductor	2024 Efficacy of Covered Conductor
Unknown	10%	70%
Lightning	90%	90%

In 2024, the estimated effectiveness of covered conductor installations against “vehicle contact” and “other contact” risk event drivers is expected to increase from 20% and 10% to 80% and 50% respectively as testing demonstrated that covered conductor installations would be effective in reducing the risk of ignition from most contacts that did not damage the covering. The “unknown” risk event driver was also increased from 10% to 70% to align with subject matter expert input that most unknown risk events are likely the result of incidental contact or wire slap which covered conductors would be effective at preventing.

The effectiveness of covered conductors against various equipment failure risk drivers was reduced in 2024 for several reasons. First, the estimated effectiveness against equipment failure drivers was originally derived using a year-over-year approach. Effectiveness was defined as the immediate protection gained from performing the covered conductor installation, which would replace aging or damaged equipment with new equipment. However, because these effectiveness numbers are being utilized for long-term investment planning, it is more appropriate to utilize a long-term effectiveness number for risk drivers. While a covered conductor will replace aging equipment in the short term, the covered conductor itself will age and degrade, reducing the effectiveness of the original installation over time. To address this issue, previous studies on the effectiveness of traditional (bare conductor) hardening were used to estimate the effectiveness of covered conductors on equipment failure risk drivers over time. As shown in Figure 12, traditional hardening had an estimated effectiveness of approximately 65% in year one, but that effectiveness steadily decreased over time and is now calculated as 32% effective. In contrast, the effectiveness of undergrounding electric lines (WMP.473) did not change, as the only ignition risk is related to vehicle contact with padmounted equipment, which remains constant over time. Because of the similarities in equipment being replaced in the covered conductor and traditional hardening initiatives, the 10-year recorded effectiveness of 30% for traditional hardening effectiveness against equipment failure risk events was also used to calculate covered conductor effectiveness for the same equipment failure risk drivers, resulting in a decrease in covered conductor efficacy from 78% in year one to 65% in year 10.

**Figure 12: Hardening Efficacy Over Time**



**Combined Mitigation Effectiveness**

Updated covered conductor effectiveness values were utilized to study the combined effectiveness of covered conductor with the Advanced Protection initiatives of FCP and EFD. Much like covered conductor installations, FCP and EFD installations are new and therefore no recorded data is available for calculating effectiveness. Therefore, subject matter expertise from the System Protection and Controls Engineering (SPACE) team that owns these Advanced Protection initiatives was utilized to estimate their effectiveness. When combining mitigations, the following formula was used (in collaboration with other IOUs):

$$\begin{aligned}
 & \textit{Combined Effectiveness} \\
 & = 1 - ((1 - CC \textit{Efficacy}) \times (1 - FCP \textit{Efficacy}) \times (1 - EFD \textit{Efficacy}))
 \end{aligned}$$

As shown in Table 16, the overall efficacy of covered conductors is estimated to be 65% and the overall efficacy of covered conductors combined with FCP and EFD is estimated to be 77%. Additional costs

associated with FCP and EFD are approximately \$164,000 per mile for FCP and \$34,000 per mile for EFD for a combined cost of approximately \$198,000 per mile. The results of this study were incorporated into an analysis utilizing the WiNGS-Planning tool to determine the impact the combined mitigations will have on mitigation selection and are described in response to ACI SDGE-23-06 (see Section 0 for details).

**Table 16: Efficacy of Covered Conductors with or without Combined Mitigations**

Risk Event Driver	CC Efficacy	FCP Efficacy	EFD Efficacy	CC+FCP+EFD Efficacy	5-Year Sum of Risk Events	CC Risk Event Reduction	FCP Risk Event Reduction	EFD Risk Event Reduction	CC+FCP+EFD Risk Event Reduction
Animal contact	90%	0%	0%	90%	246	221	0	0	221
Balloon contact	90%	0%	0%	90%	69	62	0	0	62
Vegetation contact	90%	5%	81%	98%	54	47	3	44	53
Vehicle contact	80%	5%	0%	81%	207	166	10	0	168
Crossarm damage or failure	30%	10%	64%	77%	60	18	6	38	46
Conductor damage or failure	90%	90%	93%	100%	117	105	105	108	117
Insulator and bushing damage or failure	30%	0%	91%	94%	14	4	0	13	13
Other - contact	50%	0%	0%	50%	72	36	0	0	36
Other - equipment failure	30%	10%	75%	84%	5	2	1	4	4
Capacitor bank damage or failure	30%	0%	83%	88%	6	2	0	5	5
Fuse damage or failure	30%	0%	19%	43%	92	28	0	17	40
Lightning arrester damage or failure	30%	0%	91%	94%	47	14	0	43	44
Switch damage or failure	30%	0%	83%	88%	11	3	0	9	10
Pole damage or failure	30%	5%	0%	34%	131	39	7	0	44
Voltage regulator damage or failure	30%	0%	83%	88%	4	1	0	3	4
Recloser damage or failure	30%	75%	83%	97%	6	2	5	5	6
Anchor/guy damage or failure	30%	0%	0%	30%	4	1	0	0	1

Risk Event Driver	CC Efficacy	FCP Efficacy	EFD Efficacy	CC+FCP+EFD Efficacy	5-Year Sum of Risk Events	CC Risk Event Reduction	FCP Risk Event Reduction	EFD Risk Event Reduction	CC+FCP+EFD Risk Event Reduction
Sectionalizer damage or failure	30%	0%	83%	88%	0	0	0	0	0
Connection device damage or failure	30%	20%	93%	96%	110	33	22	102	105
Transformer damage or failure	30%	0%	83%	88%	80	24	0	66	70
Wire-to-wire contact	99%	0%	88%	100%	17	17	0	15	17
Contamination	80%	0%	91%	98%	1	0.8	0	1	1
Utility Work	90%	0%	0%	90%	20	18	0	0	18
Vandalism/Theft	10%	0%	0%	10%	11	1	0	0	1
Other - All (includes wire-down & fire)	10%	50%	75%	89%	24	2	12	18	21
Unknown	70%	0%	0%	70%	654	458	0	0	458
Lightning	90%	0%	0%	90%	158	142	0	0	142
Overall Effectiveness Total	n/a	n/a	n/a	n/a	2,220	65%	12%	51%	77%

## 5.8 SDGE-23-09: New Technologies Evaluation and REFCL Implementation

### Description

SDG&E has not moved forward with piloting REFCL, or explained why it is not exploring the technology.

Discussed in Section 8.1, “Grid Design, Operations, and Maintenance” (8.1.2 “Grid Design and System Hardening”).

### Required Progress

In its 2025 Update, SDG&E must provide an update on its progress evaluating the use of REFCL as a mitigation or provide an explanation why SDG&E finds REFCL not logical and/or feasible to use as a mitigation.

### SDG&E Response

In 2020 and 2021 a study was performed on existing substation and distribution circuit infrastructure and topology to identify and quantify system changes required to deploy a Rapid Earth Fault Current Limiter (REFCL) system. Results, published in Section 4.4.2.10 of the 2022 WMP Update, are included in Appendix A. In summary, the use of an REFCL system would require substantial rebuilds because there is

a significant amount of phase-to-neutral connected customer loads and equipment rated at phase-to-neutral voltages, which is not rated to operate on an REFCL system. To protect a whole circuit with REFCL, all equipment neutral/ground references served on the circuit must be removed and replaced with phase-to-phase/delta connected equipment, which would not provide a ground source. Increased voltages seen during phase-to-ground faults on an REFCL system also require all equipment to be rated above the 12 kV nominal voltage to prevent erroneous equipment failures. This equipment may include insulators, underground cable, switches, and arresters, which may not have the right rating to operate under the higher stresses caused by an REFCL system.

The cost to implement an REFCL system on one substation feeding three distribution circuits has therefore been estimated at approximately \$26 million. These costs will scale higher with more distribution transformers feeding circuits within a substation. Substations that may have up to four distribution transformers will cost considerably more.

With approximately 70 substations and 285 distribution circuits serving the HFTD, the anticipated rebuild of infrastructure that would be needed to deploy REFCL would be cost prohibitive and would not provide coverage or mitigation for any faults outside of single phase-to-ground types. As explained in the study, an REFCL system will only reduce fault energies for single phase-to-ground faults and will not provide mitigation for faults involving multiple phases, which are a common fault on the electric distribution system. An REFCL system will have no benefit to reducing multi-phase fault energy, as the technology cannot act for these scenarios. (i.e., wire slaps or phase-to-phase foreign object contact not involving ground, such as vegetation or balloons).

Other technologies that have been developed over the last 10 years are preferred over REFCL. Technologies such as SGF Detection, SRP settings, and FCP (WMP.463) provide a diverse and layered approach to covering all types of fault scenarios possible on the distribution system. These technologies, combined with strategic undergrounding of electric lines (WMP.473) and covered conductor installation (WMP.455) and utilizing advanced meteorology and fire science data to drive their use, are sufficient mitigations to reduce wildfire risks without implementing REFCL in the service territory.

Emerging technologies, including REFCL systems, that can increase effectiveness against ignition and wildfire risk continue to be explored. SDG&E also participates in joint IOU meetings to discuss the evaluation of new technologies when in combination with each other. Working with peers in the industry will maintain an up-to-date status on REFCL systems and other technologies. Additional details are provided in the grid hardening joint studies (see ACI SDGE-23-08 in Section 5.7).

## 5.9 SDGE-23-10: Early Fault Detection Implementation

---

### Description

SDG&E plans to install EFD technology at 180 locations during the 2023-2025 WMP cycle. As SDG&E's EFD deployment program matures, Energy Safety needs SDG&E to report on its performance and effectiveness.

Discussed in Section 8.1, "Grid Design, Operations, and Maintenance" (8.1.2 "Grid Design and System Hardening").

## Required Progress

In its 2025 Update, SDG&E must:

- Provide analysis of using EFD in combination with other hardening efforts, such as covered conductor and traditional hardening, to maximize possible risk reduction. If applicable, SDG&E may adjust its EFD scope and prioritization accordingly to maximize these benefits.
- Document the performance of deployed EFD in identifying incipient faults, including the number of potential incipient faults detected and their accuracy.
- Document any instances where the early fault detection sensors successfully prevented or mitigated a potential ignition.
- Provide additional details on any maintenance requirements related to EFD.

## SDG&E Response

For an analysis of the use of EFD in combination with other hardening efforts, see ACI SDGE-23-08.

To date, there have been six possible incipient faults identified through the use of radio frequency EFD sensors, with a location accuracy of 30 feet. In addition, twelve possible incipient faults have been detected to date using Power Quality data based EFD technology, with a location accuracy in the hundreds of feet.

Radio Frequency EFD sensors detected six instances of severe wood crossarm tracking, degradation, and insulator damage on structures in the HFTD. Because these issues were detected early and addressed, any potential ignition risk from the failing equipment was mitigated.

Maintenance of EFD sensors is primarily routine in nature and follows a similar procedure and timeline as other line-side devices installed on circuits. This includes, but is not limited to:

- Periodic backup battery testing and replacement.
- Periodic remote firmware/software updates as required.
- Replacement of failed sensor nodes and other non-routine maintenance as required.

## 5.10 SDGE-23-11: Changes to Scope of Falling Conductor Protection Program

---

### Description

SDG&E has descoped some of its falling conductor protection (FCP) projects in favor of strategic undergrounding.

Discussed in Section 8.1, “Grid Design, Operations, and Maintenance” (8.1.2 “Grid Design and System Hardening”).

### Required Progress

In its 2025 Update, SDG&E must provide the following for any circuit segments originally scoped for FCP that are now targeted for strategic undergrounding:

- A list of projects that were descoped, including circuit segment name/ID, length, and associated risk score.
- Demonstration of considerations for cost/benefit analysis, deployment time, interim mitigation needs, and mitigation effectiveness for reducing ignition risk (including FCP in combination with covered conductor).
- Adjustments to FCP targets based on the above analysis, if applicable.

**SDG&E Response**

Table 17 lists FCP projects that were descoped. All of these projects are now targeted for strategic undergrounding of electric lines (WMP.473).

**Table 17: Descoped FCP Projects**

Circuit	Segment ID	Risk Score Rank	Circuit Length (miles)	Overhead HFTD Segment Length (miles)
235	CB 235	6	18	0.1
235	235-899R	8	18	9.8
237	CB 237	10	112	0.6
237	237-17R	21	112	13.6
909	909-805R	22	36	18.0
222	222-1401R	27	157	24.7
357	357-45R	29	73	9.7
521	521-14R	32	57	11.8
357	CB 357	36	73	3.9
521	521-700R	38	57	10.7
222	222-1370R	43	157	13.8
358	358-682F	48	35	10.5
357	357-50R	49	73	8.7
79	79-679R	53	61	6.0
1030	1030-20R	56	87	14.4
237	237-30R	62	112	31.7
358	358-585R	63	35	7.1
1030	1030-42R	67	87	14.0
521	521-27R	68	57	7.7
357	357-750R	69	73	7.2
78	78-26R	73	9.	5.3
222	222-1441R	76	157	6.4
358	358-33	77	35	0.4
79	79-676R	84	61	3.2



Circuit	Segment ID	Risk Score Rank	Circuit Length (miles)	Overhead HFTD Segment Length (miles)
907	907-1702R	85	47	4.7
449	449-6R	91	33	9.7
79	79-808R	92	61	10.3
907	907-1562AE	100	47	3.2
78	78-35R	102	9.	1.5
79	79-785	105	61	10.1
222	222-1364R	107	157	29.0
357	357-1299R	109	73	2.7
449	449-13R	116	33	12.0
237	237-2R	118	112	14.7
441	441-23R	128	35	5.1
441	441-30R	129	35	5.7
357	357-2049F	130	73	5.6
449	449-16R	131	33	2.0
907	CB 907	135	47	1.2
222	222-2063	141	157	4.8
441	441-27R	145	35	7.1
79	79-660R	147	61	7.3
78	CB 78	159	9.	0.04
449	449-683R	164	33	1.8
79	79-685R	170	61	3.8
1215	1215-32R	172	29	11.6
1030	1030-23R	173	87	8.0
907	907-1602	186	47	0.1
1030	1030-989R	193	87	18.3
1215	1215-12R	211	29	8.0
449	449-19R	213	33	1.5
222	222-1523R	229	157	12.5
1215	1215-28R	249	29	3.0
449	CB 449	258	0.1	0.1
222	222-2013R	291	157	15.1
237	237-1761R	303	112	7.4
441	CB 441	320	35	5.9
222	222-1503	326	157	2.4

Circuit	Segment ID	Risk Score Rank	Circuit Length (miles)	Overhead HFTD Segment Length (miles)
442	CB 442	345	33	2.3
441	441-279R	357	35	2.2
442	442-16R	367	33	10.7
907	907-1604	546	47	0.02

Other considerations for circuit segments originally scoped for FCP that are now targeted for strategic undergrounding, including cost/benefit analysis, deployment time, interim mitigation needs, and mitigation effectiveness for reducing ignition risk, are addressed in Section 0 ACI SDGE-23-06.

Scoping for FCP will not change based on the result of the joint IOU combined efficacy study. The current method for scoping work includes analysis based on SDG&E’s strategy and cost consideration in selecting circuits for strategic undergrounding of electric lines and covered conductor installation, and aims to provide protection on circuits where there is no other mitigation before implementing the combined mitigation of FCP with covered conductor installation. This is done to gain immediate risk reduction on those circuits, which are expected to remain as overhead bare conductor, before applying these additional mitigation measures on circuits which have already had risk reduction associated with covered conductor installation.

## 5.11 SDGE-23-12: Covered Conductor Inspection and Maintenance

### Description

SDG&E has not shown that its current inspection and maintenance procedures have been updated to specifically address covered conductor. In particular, SDG&E has not identified any changes that it will make to its inspection and maintenance procedures to address failure modes specifically related to covered conductor.

Discussed in Section 8.1, “Grid Design, Operations, and Maintenance” (8.1.3 “Asset Inspections”).

### Required Progress

In its 2025 Update, SDG&E must discuss how failure modes unique to covered conductor will be accounted for in its inspections, including:

- Water intrusion
- Splice covers
- Surface damage

If SDG&E determines any or all the preceding changes are unnecessary, then it must discuss how its current inspection and maintenance processes adequately address covered conductor failure modes.

## SDG&E Response

In 2024, new condition codes will be added to the SAP CMP specific to any damage or findings related to the health of primary covered conductors and their connection points on distribution electric overhead facilities.

The SAP CMP initial and annual training curriculum will also be updated to include a description of what potential issues qualified inspectors should be looking for during Distribution Overhead Patrol Inspections (WMP.488). This will include observations related to surface damage (bulging, cracking, or other imperfections), potential water intrusion (e.g. corrosion), damage to splice covers, or other issues at the connection ends.

Finally, a limited number of Distribution Infrared inspections (WMP.481) will be performed on existing covered conductor circuit segments to determine whether thermography may be useful in identifying any potential damage conditions to the covered conductor.

## 5.12 SDGE-23-13: QA/QC for Inspections

---

### Description

SDG&E is not adequately capturing findings when determining QA/QC pass rates for inspections. This may include SDG&E's new practice of using drones to perform inspections, given that drones have different findings than detailed inspections.

Discussed in Section 8.1, "Grid Design, Operations, and Maintenance" (8.1.3 "Asset Inspections").

### Required Progress

In its 2025 Update, SDG&E must:

- Describe how it has augmented its current QA/QC program to include desktop and direct field review and/or demonstrate that drone inspections adequately cover QA/QC for detailed inspections.
- Discuss how SDG&E is validating drone inspection results, results of various validation methods, and SDG&E's process for implementing improvements.
- Discuss how all findings during QA/QC audits inform SDG&E's changes to inspections moving forward, including any feedback loops, analysis of potential trends, and updates needed for training or procedures.
- Provide data analysis on work orders found during QA/QC audits of asset inspections from 2021 to 2023, including the total number of findings and the rate of these findings (i.e., percentage of structures that had work orders opened during QA/QC audit).

## SDG&E Response

Drone inspections replaced a discontinued inspection program formerly known as "QA/QC inspections" (WMP.193), which was a program that performed additional distribution inspections in Tier 3 of the HFTD on a 3-year cycle. This program was discontinued in 2022 as described in Section 8.1.3.12.2 of the 2023-2025 Wildfire Mitigation Plan.

Drone inspections (WMP.552) are performed on structures in the HFTD and the WUI. Drone inspection results are validated through multiple quality control methods as described in Sections 8.1.3.7 and 8.1.6.3 of the 2023-2025 Wildfire Mitigation Plan. Drone inspections are not used to conduct QA/QC for detailed inspections.

In the current QA/QC of the Distribution Detailed Inspections program (WMP.491), audits typically occur within 3 months of the inspection. Due to the time between inspection and audit activity, there is no way to determine whether results of the audit were present at the time of inspection. As a result, QA/QC audits of Detailed Overhead Visual Inspections (WMP.491) as described in Section 8.1.6.2 of the 2023-2025 Wildfire Mitigation Plan did not track pass/fail results between 2021 and 2023. However, QA/QC audit completion information required in the 2023 QDRs has been provided.

Going forward, the program will be enhanced by having supervisors assess 50% of the issues identified during inspection within 1 month and documenting the results of those assessments. In addition, 5% of inspections will be audited by quality control personnel via field visits and desktop review of images collected within 1 month of the completed inspection. These enhancements will track pass/fail audit results, which will be communicated back to inspectors. In addition, trends will be monitored and appropriate training will be delivered either individually or through annual refresher trainings administered to all qualified inspectors.

## 5.13 SDGE-23-14: Equipment Maintenance and Repair

### Maturity Level

---

#### Description

SDG&E does not project adequate maturity level growth for equipment maintenance and repair.

Discussed in Section 8.1, “Grid Design, Operations, and Maintenance” (8.1.4 “Equipment Maintenance and Repair”).

#### Required Progress

In its 2025 Update, SDG&E must provide a plan to increase its maturity level for equipment maintenance and repair or explain why its current maturity level is adequate. This must include discussion of the following:

- Accounting for performance history of individual equipment when establishing maintenance frequency.
- Estimating equipment service life reduction based on usage and environmental conditions.
- Including risk buy-down estimates when prioritizing its asset maintenance.

#### SDG&E Response

As stated in OEIS’ Final Decision on the 2023-2025 Wildfire Mitigation Plan, SDG&E will demonstrate an average growth in asset maintenance and repair maturity from 1.5 to 2.0 by 2025. SDG&E believes this growth in maturity is adequate for the following reasons. While performance history, usage, and environmental conditions of individual equipment are considered when developing predictive asset health models, prescriptive failure rates, and proactive asset management strategies, this information is

not used to establish maintenance frequencies or estimate reductions in service life. Because maintenance and inspection frequencies are determined by GO 165, mandated maintenance and inspection initiatives are supplemented with proactive, risk-based inspection and replacement initiatives that incorporate the factors identified above. Examples of proactive, risk-based inspections are drone inspections (WMP.552), infrared inspections (WMP.481), and Tier 3 inspections on 69kV tielines (WMP.555). Examples of proactive, risk-based wildfire mitigation initiatives are Covered Conductor (WMP.455), Strategic Undergrounding (WMP.473), and Strategic Pole Replacement Program (WMP.1189). In addition, risk prioritization models are informed by performance history, usage, and environmental conditions and are utilized to select high risk assets for supplemental inspections, but not necessarily to estimate a reduction in service life. Corrective work is prioritized based on severity of the damage and the HFTD tier as described in Section 8.1.7 of the 2023-2025 Wildfire Mitigation Plan. Section 8.1.4 of the 2023-2025 Wildfire Mitigation Plan contains more information on asset management strategies including maintenance and repair.

## 5.14 SDGE-23-15: Evaluation of Sensitive Relay Profile in Highest Risk Areas

---

### Description

SDG&E does not plan to expand its sensitive relay profile (SRP) program, nor does SDG&E show whether existing SRP coverage includes SDG&E's highest risk areas.

Discussed in Section 8.1, "Grid Design, Operations, and Maintenance" (8.1.5 "Grid Operations and Procedures").

### Required Progress

In its 2025 Update, SDG&E must:

- Provide an analysis showing the current coverage of SRP in SDG&E's highest risk areas based on SDG&E's risk models.
- Based on this analysis, provide updated targets for installing new devices for SRP coverage. This must include ensuring SRP coverage of the highest risk areas not already covered by SRP, or, alternatively, an analysis showing why this coverage is not needed.

### SDG&E Response

An analysis was performed utilizing GIS data to understand the coverage provided by SRP-enabled devices within the HFTD. The number of overhead circuit miles downstream of SRP capable devices within the HFTD, and thus protected by SRP, was compared against the total overhead circuit miles within the HFTD. The analysis shows that SRP devices currently provide coverage for 99.3% of the overhead mileage within the HFTD (see Table 18). The SRP coverage encompasses all 157 circuits with at least 1 mile of overhead distribution within the HFTD. Currently, there are no plans to install new devices, however, SRP coverage will continue to be evaluated as needed.

**Table 18: SRP Analysis Results**

Total SRP Protected Miles	3,388
Total OH HFTD Miles	3,411
% of SRP Miles Covered	99.3%

## 5.15 SDGE-23-16: Updates on Identifying Additional, Proactive HFTD Inspections

---

### Description

SDG&E is developing additional, proactive inspections within the HFTD. As SDG&E’s proactive HFTD inspections program matures, Energy Safety will evaluate its quality.

Discussed in Section 8.2, “Vegetation Management and Inspections.”

### Required Progress

SDG&E must provide Energy Safety and WMP stakeholders updates on efforts to foster collaborative learning and improvement across the industry. In its 2026-2028 Base WMP, SDG&E must report on:

- Any efforts to identify new opportunities for vegetation inspections or new inspection techniques.
- The effectiveness of newly identified inspection opportunities.
- Whether SDG&E plans to implement these inspections on a permanent basis and the justification if they are made permanent.

### SDG&E Response

In 2023, as part of the Vegetation Management off-cycle HFTD patrol (WMP.508), all stand-alone secondary construction was inspected, including potential hazard tree conflicts with all associated infrastructure such as poles and down-guys. In addition, a LiDAR strike tree analytics dashboard was developed to associate LiDAR-observed trees with current inventory trees to determine density and to potentially incorporate the data in a future enhancement of the mobile work application. In 2023 Vegetation Management also collaborated with District electric operations to develop new data collection techniques and reporting associated with post-event (e.g., PSPS de-energization, storm, fire) equipment damage assessment inspections. Finally, as mentioned in ACI SDGE-23-07 (see Section 5.6), the VMA inspection schedule for off-cycle HFTD patrol was modified using risk analytics to inform which VMAs to inspect closer to the onset of peak fire season.

Additional progress on ACI SDGE-23-16 will be reported in the 2026-2028 Wildfire Mitigation Plan, as requested by OEIS.

## 5.16 SDGE-23-17: Continuation of Effectiveness of Enhanced Clearances Joint Study

---

### Description

The large IOUs have jointly made progress addressing the Progression of Effectiveness of Enhanced Clearances Joint Study 2022 area for continued improvement (SDGE-22-20, PGE-22-28, and SCE-22-18). Energy Safety expects the large IOUs and their contracted third party to continue their efforts and meet the requirements of this ongoing area for continued improvement.

Discussed in Section 8.2, “Vegetation Management and Inspections.”

### Required Progress

In its 2025 Update, SDG&E, along with PG&E and SCE, must report on the progress and outcomes of the third-party contractor’s analysis and evaluation of the effectiveness of enhanced clearances. This must include:

- A list of the aligned variables related to vegetation risk events.
- A description of the chosen database type and architecture to warehouse the data.
- A description of how the third-party contractor incorporated biotic and abiotic factors into its analysis.
- The third-party contractor’s assessment of the effectiveness of enhanced clearances including, but not limited to, the effectiveness of enhanced clearances in reducing tree-caused outages and ignitions.

Additionally, SDGE-22-20 established the expectation that the large IOUs make incremental progress and update their analyses with each WMP submission through at least 2025. With its 2026-2028 Base WMP, SDG&E, along with PG&E and SCE, must attach a white paper which discusses:

- The IOUs’ joint evaluation of the effectiveness of enhanced clearances including, but not limited to, the effectiveness of enhanced clearances in reducing tree-caused outages and ignitions.
- The IOUs’ joint recommendations for updates and changes to utility vegetation management operations and best management practices for wildfire safety based on this study. This may include the IOUs’ recommendations for updates to regulations related to clearance distances.

Furthermore, SDG&E must, as a result of this study and white paper:

- Assess the effectiveness of enhanced clearances combined with other mitigations including, but not limited to, covered conductor and protective equipment and device settings (e.g., EPSS, fast curve).
- Provide a plan for implementing the results and recommendations of the third-party contractor analysis and the white paper. This plan must include trackable milestones and timelines for implementation. SDG&E must also provide a list of recommendations it is not implementing and why it is not selecting them for implementation.

## SDG&E Response

The Joint IOU Study on Enhanced Vegetation Clearances for Wildfire Mitigation technical work started in November 2022 and is scheduled to be completed by June 2024. The study is being completed by a third-party contractor, Electric Power Research Institute (EPRI). The study is divided into four phases: Database Evaluation; Database Development; Data Analysis; and Discussion of Options. Currently, the third-party contractor is finalizing the common database and plans to populate it in the first quarter of 2024. Analysis is anticipated to begin in March 2024.

### 5.16.1 Aligned Vegetation Risk Event Variables

Immersive discussions revealed significant differences between the databases from the three utilities (i.e., the Joint IOUs, or SCE, PG&E, and SDG&E). There were thousands of variables across the three different databases, only a subset of which were similar in terms of definition and methods of recording. The research team and IOU subject matter experts discussed and selected the variables which were the most instructive for understanding the effects of enhanced clearance on wildfire mitigation.

EPRI examined a wide range of aligned variables from the three companies related to vegetation risk events. These were included in the common database, i.e., the joint IOU database, built from the individual IOU databases. Variables included are the definition of clearance levels/line clearances, timing of clearances, tree growth rates, event outages, trim codes, types of disturbances, weather at the time of the outage, distance to line of tree caused outage, definition of high fire risk area, date and time of tree caused outage, tree numbering system, tree species, ignition events, tree condition, and tree height, among other variables.

EPRI has streamlined the joint IOU database to include approximately 25 variables for the overall analysis. The IOUs have supplied the desired time series data to support the project that includes over a decade of time series data for some variables. EPRI has built out a SQL database that contains tables for the common variables as well as individual IOU-specific tables. These datasets contain all the original data variables from the individual IOUs to understand the unique characteristics of vegetation management practices more fully from each utility. There are plans to conduct individual analyses as well as the combined analysis of the datasets.

The database schema in Section 5.16.2 shows common variables used in the study. There are currently 10 individual tables housing the common variables, which have been combined into Table 19.

**Table 19: Common Vegetation Management Variables**

Field	Data Type and Size	Definition
<b>Table 1: DataSet</b>		
[DataSetID]	[tinyint]	Database table identification ID
[UtilityID]	[tinyint]	Utility (foreign key)
[Source]	[varchar](50)	Utility data set name
<b>Table 2: Utility</b>		
[UtilityID]	[tinyint]	Database table identification ID
[Utility]	[varchar](200)	Utility name



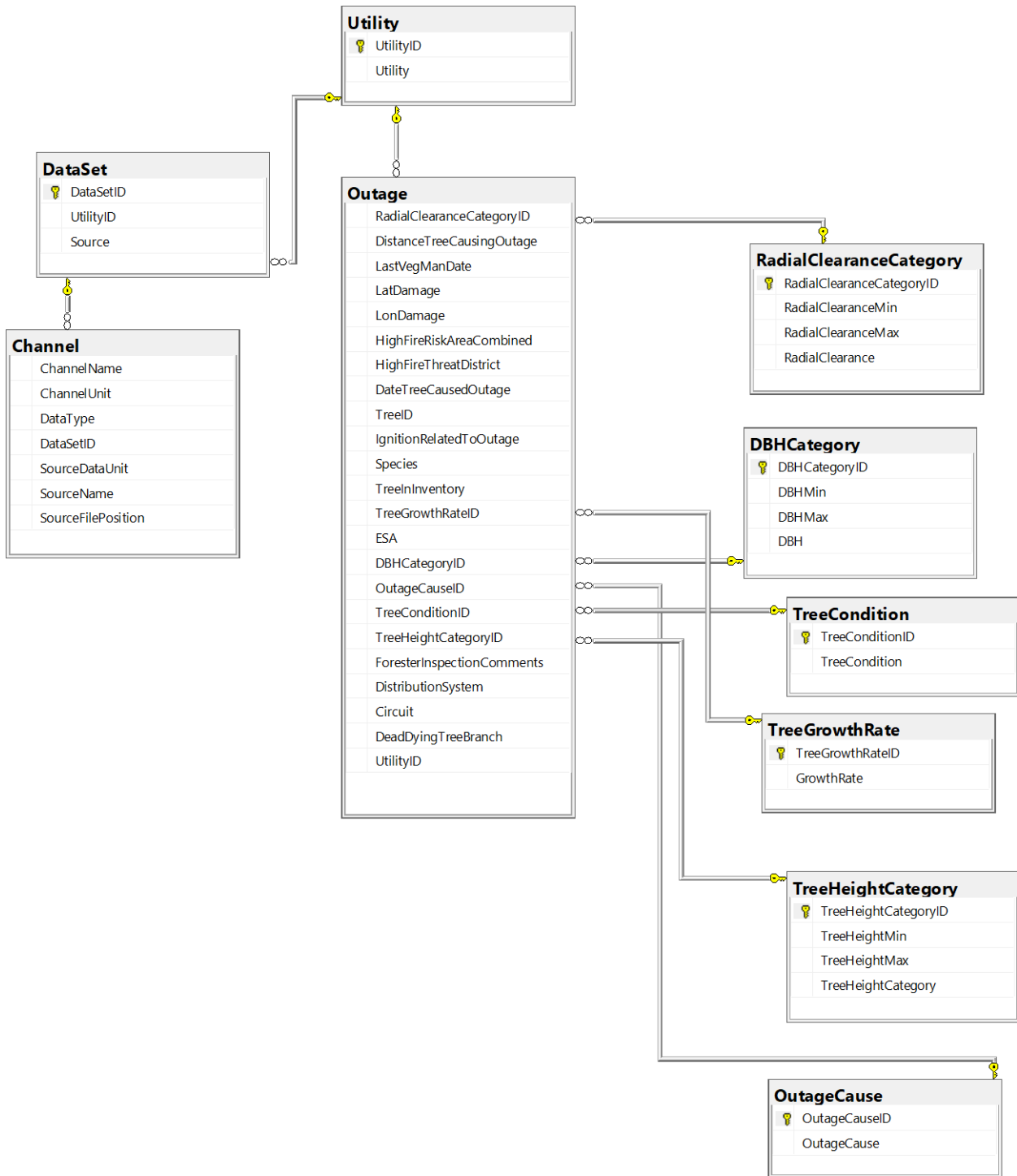
Field	Data Type and Size	Definition
<b>Table 3: Channel</b>		
[ChannelName]	[varchar](50)	Data point
[ChannelUnit]	[varchar](10)	Data unit
[DataType]	[varchar](10)	Data type
[DataSetID]	[tinyint]	Source data set (foreign key)
[SourceDataUnit]	[varchar](10)	Source data unit
[SourceName]	[varchar](50)	Source data name
[SourceFilePosition]	[smallint]	Source data position in source data set
<b>Table 4: Outage</b>		
[RadialClearanceCategoryID]	[tinyint]	Database table identification ID
[DistanceTreeCausingOutage]	[real]	Distance between circuit and tree causing outage
[LastVegManDate]	[datetime2](0)	Last date of vegetation management activity
[LatDamage]	[float]	Latitude of the tree that incurred damage
[LonDamage]	[float]	Longitude of the tree that incurred damage
[HighFireRiskAreaCombined]	[bit]	Did outage occur in a High Fire Risk Area? (Y/N)
[HighFireThreatDistrict]	[bit]	Did outage occur in a High Fire Threat District (Y/N)
[DateTreeCausedOutage]	[datetime2](0)	Date of outage caused by tree
[TreeID]	[varchar](20)	Tree ID
[IgnitionRelatedToOutage]	[bit]	Is the ignition related to the outage? (Y/N)
[Species]	[varchar](200)	Tree species
[TreeInInventory]	[bit]	Is tree in SCE's tree inventory? (Y/N)
[TreeGrowthRateID]	[tinyint]	Tree Growth Rate (foreign key)
[ESA]	[bit]	Did outage occur an Environmental Sensitive Area (ESA)? (Y/N)
[DBHCategoryID]	[tinyint]	DBH Category (foreign key)
[OutageCauseID]	[tinyint]	Outage Cause (foreign key)
[TreeConditionID]	[tinyint]	Tree Condition (foreign key)
[TreeHeightCategoryID]	[tinyint]	Tree Height Category (foreign key)
[ForesterInspectionComments]	[varchar](max)	Comments from Forester Inspection
[DistributionSystem]	[bit]	Did outage occur in Distribution System? (Y/N)
[Circuit]	[varchar](20)	Circuit name
[DeadDyingTreeBranch]	[bit]	Did Dead and Dying tree branch cause outage? (Y/N)
[UtilityID]	[tinyint]	Utility (foreign key)
<b>Table 5: Outage Cause</b>		
[OutageCauseID]	[tinyint]	Database table identification ID
[OutageCause]	[varchar](200)	Description of cause of outage

Field	Data Type and Size	Definition
<b>Table 6: Radial Clearance</b>		
[RadialClearanceCategoryID]	[tinyint]	Database table identification ID
[RadialClearanceMin]	[int]	Radial Clearance lower boundary
[RadialClearanceMax]	[int]	Radial Clearance high boundary
<b>Table 7: Diameter at Breast Height (DBH)</b>		
[DBHCategoryID]	[tinyint]	Database table identification ID
[DBHMin]	[int]	DBH low boundary
[DBHMax]	[int]	DBH high boundary
<b>Table 8: Tree Condition</b>		
[TreeConditionID]	[tinyint]	Database table identification ID
[TreeCondition]	[varchar](50)	Description of tree condition
<b>Table 9: Tree Growth Rate</b>		
[TreeGrowthRateID]	[tinyint]	Database table identification ID
[GrowthRate]	[varchar](10)	Tree growth rate ??
<b>Table 10: Tree Height Category</b>		
[TreeHeightCategoryID]	[tinyint]	Database table identification ID
[TreeHeightMin]	[int]	Tree Height low boundary
[TreeHeightMax]	[int]	Tree Height high boundary

### 5.16.2 Description of Database Type and Architecture

The SQL database sits on the EPRI Data Science Platform, a secure platform located on the EPRI-owned and -managed server that will be accessible to the Joint IOUs for querying the supplied data. The data was ingested into the joint IOU database in its raw form (e.g., as CSV, Excel, and/or spatial format file types). A subset of each IOU’s original data was incorporated into the common database. Figure 13 shows the database scheme for the common database.

**Figure 13: SQL Database Scheme**



The database includes a joint dataset as well as individualized databases for each IOU so that each IOU’s subject matter experts would be able to conduct separate, individual, and confidential analyses if they would like to further explore the processed data. EPRI will provide access to the Data Science Platform for the SMEs at each IOU. Additionally, virtual machines with applications specified by each IOU will be

created within the Data Science Platform allowing the data to remain within the secure EPRI environment.

### 5.16.3 Incorporation of Biotic and Abiotic Factors

EPRI is finalizing the common database and plans to populate it in the first quarter of 2024. Analysis is anticipated to begin in March 2024. EPRI will be determining how to use abiotic factors, and wind speed in particular, in the analysis in a way that is standard across the utilities. EPRI will likely use a publicly available dataset for the joint IOU analysis. Discussions are underway to determine how best to approach the abiotic factors with the EPRI climate researchers and utility subject matter experts.

See above for the list of common variables to be included in the analysis.

### 5.16.4 Third-Party Contractor’s Assessment of the Effectiveness of Enhanced Clearances

EPRI is finalizing the common database and plans to populate it in the first quarter of 2024. Analysis is anticipated to begin in March 2024. At this time, an assessment of the effectiveness of enhanced clearances in reducing tree-caused outages and ignitions or for other outcomes has not been finalized.

### 5.16.5 Progress on the Evaluation of Enhanced Clearances and Recommendations

SDG&E will report on the progress of the following parts of SDGE-23-17 in its 2026-2028 Wildfire Mitigation Plan, as requested by the OEIS.

- The IOUs’ joint evaluation of the effectiveness of enhanced clearances including, but not limited to, the effectiveness of enhanced clearances in reducing tree-caused outages and ignitions.
- The IOUs’ joint recommendations for updates and changes to utility vegetation management operations and best management practices for wildfire safety based on this study. This may include the IOUs’ recommendations for updates to regulations related to clearance distances

## 5.17 SDGE-23-18: Update Targets Table with Planned Improvements’ Measurable Targets

---

### Description

SDG&E includes measurable targets in its planned improvements section of its initiatives. However, these targets are not included in OEIS Table 8-23 “Situational Awareness Initiative Targets by Year.”

Discussed in Section 8.3, “Situational Awareness and Forecasting.”

### Required Progress

In its 2025 Update, SDG&E must provide a more comprehensive list of measurable targets in its table “Situational Awareness Initiative Targets by Year,” including targets included in its planned improvements section along with relevant timelines to track progress.

## SDG&E Response

The Situational Awareness and Forecasting objectives contain the majority of planned improvements, as shown in Section 8.3.1.1 of the 2023-2025 Wildfire Mitigation Plan. In response to ACI SDGE-23-19, WMP.447, formerly known as Advanced Weather Monitoring and Weather Stations, will evolve into a new initiative: Weather Station Maintenance and Calibration (WMP.1430) in 2024 and will target annual maintenance of weather stations. Progress on objectives may be found in SDG&E’s 2023 Annual Report on Compliance.

In the 2023-2025 Wildfire Mitigation Plan, there were several sections that discussed planned improvements in situational awareness and forecasting. Section 8.3.2.3 contained planned improvements for environmental monitoring systems, Section 8.3.3.3 contained planned improvements for grid monitoring systems, 8.3.5.3 contained planned improvements for weather forecasting, and 8.3.6.3 contained planned improvements for the FPI. Planned improvements discussed in these sections don’t directly impact wildfire risk; they are foundational to supporting established wildfire initiatives. For this reason, no targets were established for the 2023-2025 WMP cycle.

## 5.18 SDGE-23-19: Weather Station Maintenance and Calibration

---

### Description

SDG&E reports having 222 weather stations in its network that collect weather data. Frequent calibration and maintenance of weather stations is crucial for ensuring accurate, reliable, and high-quality data. As SDG&E performs its annual weather station maintenance and calibration, Energy Safety will need SDG&E to report on the following to verify the integrity of the data collected from its weather station network.

Discussed in Section 8.3, “Situational Awareness and Forecasting.”

### Required Progress

SDG&E must:

- Continue to maintain and keep a log of all the annual maintenance and calibration for each weather station, including the station name, location, conducted maintenance, in compliance with SDG&E’s weather station calibration training document,<sup>184</sup> as well as document the annual replacement of the fuel sensors listed in the above reference. The document must also include the length of time from initiation of a repair ticket to completion and the corrective maintenance performed to bring the station back into functioning condition.

In its 2025 Update, provide documentation indicating the number of weather stations that received their annual calibration, and the number of stations that were unable to undergo annual maintenance and/or calibration due to factors such as remote location, weather conditions, customer refusals, environmental concerns, and safety issues. This documentation must include:

- The station name and location.
- The reason for the inability to conduct maintenance and/or calibration.

- The length of time since the last maintenance and calibration.
- The number of attempted but incomplete maintenance or calibration events for these stations in each calendar year.

**SDG&E Response**

The weather station network consists of 222 weather stations throughout the service territory. Six of these stations are owned by SDG&E but are maintained by Forest Technology Systems (FTS). SDG&E is responsible for maintenance and calibration of the other 216 weather stations.

In 2023, annual maintenance on the weather station network was performed on all stations except two, which could not be visited due to loss of access (see Table 20). These two inaccessible weather stations will be visited and maintained at the next available opportunity pending property owner agreement and/or road improvements or relocation of the station, if required. Maintenance and calibration records of all 216 weather stations for 2023 are detailed in Appendix B.

In 2024, WMP.447, formerly known as Advanced Weather Monitoring and Weather Stations, will be reinstated as Weather Station Maintenance and Calibration and will target annual maintenance of the 216 weather stations (see Section 4.1.1).

Maintenance will include an annual calibration in alignment with National Weather Service (NWS) procedures and routine replacement of aging sensors. The Weather Station Network standard covers the general purpose, installation, maintenance and access to the weather data. The Weather Station Inspection, Testing, and Maintenance standard defines the procedure for performing maintenance and calibration of every weather station in the network at least once annually. Beginning in 2024, maintenance and calibration activities will be reported via the QDR process.

**Table 20: Weather Stations Unable to Undergo Annual Maintenance**

Station Name	Station Location	Date of Last Maintenance	Reason	Number of Attempted Events
5176	33.27605 -116.872899	6/15/2021	As of 2023, crews have been unable to perform maintenance due to the access road being washed out. A new site is being assessed	n/a; inaccessible
1915	33.301305 -116.912993	3/7/2022	As of 2023, the property owner has denied SDG&E access to the station site. A new location is being assessed.	n/a; inaccessible

## **Appendix A: REFCL Impact Study for Descanso Substation**

---



**QUANTA**  
TECHNOLOGY

**REPORT**

# REFCL Impact Study for Descanso Substation

**PREPARED FOR**

San Diego Gas & Electric  
(SDG&E)

**DATE**

June 11, 2020  
(Version 2)

**PREPARED BY**

Juergen Holbach  
[JHolbach@Quanta-Technology.com](mailto:JHolbach@Quanta-Technology.com)  
(919) 376-5195

Vic Romero

[VRomero@Quanta-Technology.com](mailto:VRomero@Quanta-Technology.com)  
(919) 428-9332

**QUANTA TECHNOLOGY, LLC**

4020 Westchase Boulevard, Suite 300, Raleigh, NC 27607 USA

RALEIGH (HQ) | TORONTO | SAN FRANCISCO BAY AREA | SOUTHERN CALIFORNIA | CHICAGO

**[www.Quanta-Technology.com](http://www.Quanta-Technology.com)**

Quanta Technology, LLC is a wholly-owned subsidiary of Quanta Services, Inc. (NYSE: PWR)

© 2020 QUANTA TECHNOLOGY, LLC | CONFIDENTIAL & PROPRIETARY





**DISCLAIMER:** All data used by Quanta Technology for this report was provided by the Customer, vendors, and industry publications. Quanta Technology deliverables are based partly on limited data provided by the Customer and partly on limited data provided by the vendors, the accuracy and completeness of which Quanta Technology has not verified. Quanta Technology is not performing analysis or evaluation of the accuracy or completeness of any data nor is Quanta Technology providing any recommendations to the Customer. The Customer acknowledges that Quanta Technology does not have access to, nor is it being asked to evaluate, numerous other business considerations, risks, impacts, intended or unintended consequences, or outcomes that may determine the value or use of Quanta Technology deliverables, or any related course of action chosen at the sole discretion of the Customer.

**Report Contributors:**

- Masoud Davoudi
- Juergen Holbach
- Jean-Christophe Lesieur
- Jeff McElray
- Shashwat Shekhar
- Vic Romero
- John Widdifield

**VERSION HISTORY:**

Version	Date	Description
0.1	4/14/2020	Initial submission
1	5/11/2020	Final Report V1
2	6/11/2020	Final Report V2



## EXECUTIVE SUMMARY

---

### Study Purpose

The purpose of this Rapid Earth Fault Current Limiter (REFCL) study is to identify the requirements for implementing a REFCL scheme at the 69/12kV Descanso Substation, which feeds three 12kV circuits within the Tier 3 High Fire Threat District (HFTD) of San Diego Gas & Electric's service territory. This evaluation details the various electric infrastructure upgrades, new equipment installations, cost estimates, and operational impacts associated with implementing a REFCL scheme on a system that was never designed to do so. This report also draws comparisons to various system protection practices used for fire mitigation and details the pros and cons of each. The results provided are to be considered initial estimates since neither this practice nor the technology is currently widely utilized in the United States.

### REFCL Concept Overview

REFCL is currently being widely implemented in Australia and experimented on in the Western United States to reduce fire ignition risk as a result of energized line-to-ground faults. A line-to-ground fault can result from a phase conductor coming into contact with either a different phase conductor or a grounded object which may result in a wire-down event, an occurrence that has various causes. Some causes of a wire-down event can include high winds, vegetation contact, foreign objects, or equipment failure. REFCL is designed to significantly limit the ground fault current immediately after the line-to-ground fault occurs, which can reduce the risk of ignition.

Electric utilities in the United States have primary distribution systems that are normally wye-grounded at the source of the substation. The substation transformer wye-grounding can be implemented as a solid connection to the ground grid or can be connected via an impedance between the wye connection and the ground. Depending on the utility, the distribution lines can serve either phase to phase connected load or phase to neutral connected load.

Unlike the United States, parts of Europe have implemented a primary distribution system as ungrounded for over 100 years. Without the ground connection, there is a significant reduction to the line-to-ground fault current. The remaining line-to-ground fault current mainly results from line-to-ground capacitance on the distribution circuits. An early application, which further reduces the line-to-ground capacitance current, is the Peterson Coil. Implemented in the early 1900s, it is an inductance placed between the substation transformer wye connection and the ground. If the substation transformer is delta connected, a grounding bank is installed with the Peterson Coil connected at the wye. The Peterson Coil is sized to match the overall line-to-ground capacitance from the distribution circuits.

Following the 2009 Australian Black Saturday bushfires, the Victorian Government implemented multiple requirements to reduce the risk of future fires. One of the major requirements was for the reduction of the voltage on the faulted conductor in relation to the station earth when measured at the substation for high impedance faults (25,400 Ohms). This voltage must be reduced to 250 volts within 2 seconds. To achieve this, the installation of REFCL to rapidly limit the ground fault current when a line to ground fault occurs was proposed.



The GFN technology monitors neutral to ground voltage in the substation. When the value exceeds established parameters, the GFN injects current to quickly offset the fault current that occurs.

In Australia, Swedish Neutral has been selected as the primary vendor for this technology because, based on tests performed, it best meets the requirements.

## Key Challenges

Besides the new substation hardware required for implementation, the REFCL application presents multiple challenges that are uncommon for U.S. electric utilities. Below are some of these key challenges covered in the body of this report:

- To implement the REFCL, the distribution system line-to-ground capacitance must be determined for the sizing of the GFN equipment. Also, the line-to-ground capacitance must be very well balanced to maximize the ability to detect a line-to-ground fault. Accurate phase identification is a requirement for accurate capacitance analysis. Although Synergi Electric, SDG&E's tool of choice for modeling its distribution system, was used for this analysis, it does not currently have accurate phase identification because the model uploaded in Synergi is pulled from SDG&E's Geographic Information System (GIS) which does not have accurate phase identification. As described in the report, phase identification needs to be performed for accurately modeling in Synergi.
- On a system implementing the REFCL, once a line-to-ground fault occurs, the fault detection is based on the overall substation ground-to-neutral voltage shift, known as the zero-sequence voltage ( $V_0$ ). To identify and isolate the faulted circuit, a new protection scheme must be implemented. The  $V_0$  detection and new protection schemes are available within the equipment provided by Swedish Neutral.
- When a line-to-ground fault occurs, the faulted phase's line to ground voltage goes to zero, but the line-to-line voltage across all three phases remains. The challenge is that the un-faulted phases' phase-to-ground voltage increases, resulting in the phase-to-phase voltage magnitude. This increase in voltage requires that some equipment must be replaced to withstand that higher voltage.
- Circuits implemented with REFCL must have no phase-to-neutral connected load since there would not be a properly grounded neutral. Descanso Substation does serve some underground phase-to-neutral connected loads, which must be converted to phase-to-phase loads if REFCL is to be implemented.

### ***Descanso Substation: Existing Major Equipment Review***

The existing equipment within Descanso Substation was evaluated to decide if the equipment needed to be replaced due to either overvoltage impacts or load increases from the Swedish Neutral equipment.

Due to overvoltage concerns, the following equipment was determined as needing to be replaced with a higher voltage rating:

- Any installed substation 12kV surge arresters

Outside the scope of this project, SDG&E plans to replace an existing single-phase 12kV 10kVA station light and power transformer with a 25kVA one.



### ***Descanso Substation: REFCL New Equipment Requirements***

Implementation of REFCL will require the installation of new equipment inside the Descanso Substation. Swedish Neutral provides a container design that includes almost all of the equipment required for implementation. This container is available with two options.

One option is for the container to include all hardware required for the GFN system plus a zigzag grounding transformer, which provides the customized neutral-to-ground connection required for the GFN system. This container would require 12kV service to energize the zigzag grounding transformer. The zigzag transformer also serves as the SL&P for the GFN container.

The second option is to not include the zigzag transformer in the container and instead use the substation bank wye neutral-to-ground connection. Three new 12kV 50kVA GFN station service transformers are to be installed to service 400Y/230V loads required by the new Swedish Neutral equipment.

With either option, a single-phase recloser is required to be connected to the substation bank's wye neutral-to-ground connection to disconnect the ground connection when REFCL is activated and reconnect the ground when REFCL will not be used.

Besides the GFN equipment, additional equipment is required. This includes the installation of current transformers (CTs) on each phase of the existing 12kV circuit breakers. The phase CTs for each breaker must be summed and the summation is used to measure the zero-sequence current.

### ***Descanso Substation: REFCL Layout Evaluation***

The expected dimensions of the Swedish Neutral GFN container is 20 ft long, 8 ft wide, and 8.5 ft high. To fit the GFN container inside the Descanso Substation, SDG&E will be removing an existing 69kV grounding transformer that is no longer needed at this location. This removal will allow the GFN container to fit inside the Descanso Substation without requiring additional space.

### ***Existing Relaying Equipment Evaluation and Upgrades***

Since the purpose of REFCL is to significantly reduce the line-to-ground fault current, existing SDG&E practices to detect such faults will not work. (Reference SDG&E System Protection Standard (SPS) 2101 – SDGE Distribution Settings Methodology) However, the GFN container includes the required protection system, which detects that a line-to-ground fault has occurred on one of the circuits based on an increase of the zero-sequence voltage,  $V_0$ . Then, as the fault current is quickly reduced, the GFN protection system detects which circuit had the fault and can then send a signal to that circuit breaker to operate should the customer wish to isolate enact tripping under this condition.

### ***12kV Feeders Capacitance Balancing***

An analysis was performed to determine the requirements for capacitance balancing on the 12kV distribution circuits fed by Descanso Substation. SDG&E's Synergi model was used for the analysis, but as mentioned before (and confirmed via this analysis) the phase identification in Synergi is known to be less-than-accurate. However, it was used to understand the potential requirements for balancing once phase identification is accurately performed in the future. Multiple options were identified to perform capacitance balancing. One solution was to solely use secondary voltage capacitor units connected via



pole mounted 25kVA single-phase phase to ground connected transformers. Although energized at 6.9kV, these transformers need to be 12kV rated due to exposure to phase to phase voltage during a line to ground fault on a different phase. A second solution was to begin with phase swaps as a first step and then use secondary capacitors to complete the balancing. To confirm accurate balancing, imbalance measurements must be performed; currently, such measurements can only be performed within the substation.

### ***12kV Feeder Equipment Rating Evaluation***

One major challenge with the REFCL application is the overvoltage that occurs when a line-to-ground fault takes place. Various SDG&E 12kV distribution equipment such as arresters, underground cables, transformer bushings, and insulators was never designed to withstand a line-to-ground voltage rise equivalent to the system line-to-line voltage experienced during faults on a REFCL-based system. This means an evaluation must be made to ensure the equipment on the distribution circuits is sized to appropriately handle this voltage rise when faults inevitably occur. This evaluation identified that 1,842 lightning arresters and about 26 miles of underground cables on Descanso's 12kV system need to be replaced. Also, as stated under the "Key Challenges" above, a phase-to-ground underground system on C78 needs to be converted to phase-to-phase, which requires replacement of padmount transformers and their accompanying underground cables. A voltage regulator also needs to be re-configured from a wye connection to a closed delta.

### ***REFCL Operations Options and Impacts***

When the GFN detects a line-to-ground fault on the substation, the faulted circuit is detected and de-energized immediately. Downstream reclosers are not able to detect the fault and will not operate. Currently, a protection system method to determine the faulted section is not widely available from a commercial standpoint, so the entire circuit patrol would be required should the REFCL system trip one of the distribution circuits. During low- or no-fire risk periods, options include opening field reclosers and performing a fault test to identify the faulted section. There are options to fully deactivate the REFCL system during non-fire risk periods.

### ***REFCL Benefits and Evaluation***

A protection philosophy comparison for the Descanso circuits is provided in the report. The comparisons include the following:

- Sensitive setting profiles, known as Profile 3 or Sensitive Relay Profile (SRP), for phase and ground elements are currently applied to SDG&E field reclosers with minimal delay and are enabled during elevated or extreme fire potential periods. These settings are designed and programmed just above historic load conditions for each device to ensure that any abnormal condition caused by faults on the system ensures the operation of the field device as quickly as possible to reduce fault energy. When in operation, all reclosers in the series on that feeder section are likely to operate for any downstream faults.
- Sensitive ground fault (SGF) settings are applied to field reclosers with the expectation that reclosers in the series will coordinate on a slower time delay staggering. SGF settings are programmed in SDG&E field reclosers to detect a rise in the residual ground current that is indicative of High Impedance Faults



(HIFs). SDG&E trends the neutral current of each recloser to develop specific setpoints for each device to ensure proper coordination and operation for its SGF pickups.

- Distribution Falling Conductor Protection (DFCP) will be applied to the Descanso circuits. The plan is to implement DFPC on the feeder sections and laterals that are over one-half (0.5) mile. A key challenge is the required communication system performance to send signals for de-energizing. DFPC will only reduce the risk of ignitions caused by wire-down events resulting from broken conductors.
- REFCL is the technology being evaluated by this study. If the technology works as expected, it should significantly reduce the risk of ignition due to line-to-ground faults.

The data provided by SDG&E showed that between 2015 and 2019, 127 ignitions occurred company-wide that were related to the distribution system. The top three causes were balloons (19), vegetation (17), and vehicle contacts (17). There were nine wire-down events, and it is not known how many were phase-to-phase faults. Also, besides the known wire-down events, it is not known if the other events ended as wire-down events.

While it is impossible to put an exact number on fire-ignition incidents that could have been averted using REFCL technology during this recorded period, there is a reasonable chance that a fair number of events could have been prevented, provided that those events had evolved into an earth fault and that no fire had already been ignited prior to detection.

A response to a questionnaire has been received by SDG&E from a utility that has been implementing REFCL for wildfire risk reduction. One question was regarding the success of REFCL. Their response was “Given that we are only just approaching the end of our first summer with our REFCLs operating at required capacity by the regulations, we have not had time to collate our experiences.”

## Conclusions

The following summary table includes the overall estimated cost to implement REFCL at the Descanso Substation. The estimate uses what is described in the report as Option 2 and Solution 1. Option 2 does not include the zigzag transformer in the GFN container. Solution 1 uses only secondary capacitors for balancing in lieu of physical phase additions or swaps in the field. The overall estimate is approximately \$26.1M.

Cost estimates are based on currently available information. The cost methodology to perform these estimates centered around using SDG&E’s Work Order Authorization form for substation and distribution capital projects and their estimated indirect costs. The substation costs were calculated for two optional installations of either a self-contained GFN container or providing a separate AC station service from the main substation 12kV bus. The substation options were evaluated using estimated direct and indirect costs which were verified by SDG&E Substation Engineering. Additional SDG&E costs in the substation estimates included costs of removal of the 69kV grounding bank, the grounding bank foundation and oil containment, and in-house assistance and support. The distribution system replacements, phase swaps, and capacitor balancing units were estimated based on expected daily vehicle and crew rates to perform the work along with the direct and indirect cost of all materials. No salvage credits were assumed.

The use of REFCL technology with the objective to reduce the probability of fire ignition for ground faults is a relatively new application that has been installed in Australia and other countries over the last 5 years.



At this time, there are no reliable statistical data available that document whether this scheme is successful in mitigating fire risk. On the other hand, the use of an arc suppression coil for system grounding has been in use around the world for over 100 years, and, as such, the challenges are well understood and documented. Further, REFCL uses residual current compensation (RCC), and its impact on the power system and fault behavior must be further investigated prior to a pilot project. Testing should be pursued to determine the following: 1) how well the REFCL prevents ignition, 2) how a REFCL system will impact the power system, and 3) how well the GFN protection system can detect whether a fault has occurred and which circuit had the fault. Also, high voltage testing should be considered for confirming if existing equipment can withstand the overvoltage. Testing can also confirm that the secondary capacitor installations operate as expected

**Option 2 and Solution 1 Summarized Costs (includes 30% Contingency)**

Description	Estimated Cost
Descanso Substation	\$3,505,207
Transformer Replacements	\$7,347,351
Arrester Replacements	\$4,173,149
Phase Swaps	\$0
Cable Replacements	\$10,582,682
Capacitor Balancing Units	\$235,009
Miscellaneous	\$295,685
<b>Total for Option 2 and Solution 1</b>	<b>\$26,139,083</b>



## TABLE OF CONTENTS

EXECUTIVE SUMMARY..... iii

ACRONYMS, INITIALIZATIONS, AND SYMBOLS ..... 1

1 INTRODUCTION ..... 2

    1.1 Study Purpose ..... 2

    1.2 REFCL Concept Overview ..... 3

    1.3 Key Challenges with Implementation of REFCL ..... 4

2 DESCANSO SUBSTATION ..... 6

    2.1 Existing Equipment Evaluated ..... 6

    2.2 New Equipment Evaluation ..... 8

        2.2.1 Swedish Neutral REFCL Container ..... 8

        2.2.2 Arc Suppression Coil (ASC) ..... 12

        2.2.3 Residual Current Compensator (RCC)..... 13

        2.2.4 Metering Current Transformers ..... 14

        2.2.5 Grounding Breaker/Switch ..... 14

        2.2.6 Specific Equipment for Option 1 ..... 14

        2.2.7 Specific Equipment for Option 2 ..... 15

    2.3 Layout Evaluation and Findings ..... 15

    2.4 Estimated Substation Cost Options ..... 17

3 EXISTING RELAYING EQUIPMENT EVALUATION AND UPGRADES ..... 19

    3.1 General Protection Considerations ..... 19

    3.2 Ground Over Current Based Fault Detection ..... 19

    3.3 Ground Fault Clearing with REFCL ..... 20

        3.3.1 Ground Fault Detection ..... 20

        3.3.2 Ground Fault Direction ..... 21

        3.3.3 SDG&E’s Ground Fault Clearing Strategy..... 23

    3.4 Communication Link Between Swedish Neutral Container and Control Shelter ..... 25

4 12KV FEEDER CAPACITANCE BALANCING ..... 27

    4.1 Importance of Capacitance Balancing ..... 27

    4.2 Feeder Sections to be Balanced ..... 28

    4.3 Synergi Methodology for Capacitance Balancing Analysis ..... 32

        4.3.1 Using Synergi ..... 32

        4.3.2 Confirming Synergi Results ..... 33

        4.3.3 Calculating the Capacitances from Synergi Exported Values..... 33





- 4.4 Capacitance Balancing Method ..... 35
  - 4.4.1 Capacitance Values in the Base Case ..... 35
  - 4.4.2 Capacitance Values After Performing Phase Swaps ..... 44
  - 4.4.3 Capacitance Values After Performing Phase Swaps and Adding Conductors ..... 51
  - 4.4.4 Importance of Each Section and the Studied Configurations ..... 56
  - 4.4.5 Methodology for Adding Secondary Capacitor Banks ..... 56
- 4.5 Results of Capacitance Balancing ..... 59
  - 4.5.1 Solution 1: Capacitor Banks ..... 59
  - 4.5.2 Solution 2: Phase Swaps and Capacitor Banks ..... 60
  - 4.5.3 Solution 3: Phase Swaps, Additional Conductors, and Capacitor Banks ..... 61
  - 4.5.4 Comparison Between Solution 1, 2, and 3 ..... 62
- 4.6 Estimated Cost for Capacitance Balancing ..... 63
- 4.7 Other Considerations ..... 64
  - 4.7.1 Circuits’ Phase Identification ..... 64
  - 4.7.2 Impact of Fuse Operations ..... 66
  - 4.7.3 Capacitance Field Measurements ..... 67
- 5 12KV FEEDERS EQUIPMENT RATING EVALUATION ..... 69
  - 5.1 Overhead System Equipment ..... 69
    - 5.1.1 12-kV Feeders Equipment Rating Evaluation ..... 69
  - 5.2 Estimated Costs for Overhead System Upgrades ..... 79
  - 5.3 Underground System Equipment ..... 80
    - 5.3.1 3-Phase and 2-Phase Underground System Equipment ..... 80
    - 5.3.2 Medium Voltage Underground Cables ..... 81
    - 5.3.3 Medium Voltage Cable Terminations Rated 2.5kV to 46kV ..... 82
  - 5.4 Estimated Costs for Underground System Upgrades ..... 85
  - 5.5 Primary System Customers ..... 86
- 6 REFCL OPERATIONS OPTIONS AND IMPACTS ..... 87
  - 6.1 Option 1: REFCL Activated During Extreme FPI ..... 87
  - 6.2 Option 2: REFCL Activated with Different Settings ..... 87
  - 6.3 Option 3- REFCL Not Activated ..... 88
  - 6.4 REFCL Activation Substation Grounding ..... 88
- 7 REFCL BENEFITS AND EVALUATION ..... 89
  - 7.1 Earth Fault Current Management ..... 89
  - 7.2 Comparison with SDG&E Current Practices ..... 90
    - 7.2.1 SDG&E Ground Relaying Philosophy ..... 90
    - 7.2.2 Distribution Falling Conductor Protection (DFCP) ..... 95



7.2.3 Public Safety Power Shutoff (PSPS) ..... 96

7.2.4 Restricted Earth Fault Current Limiter (REFCL)..... 97

7.3 SDG&E Wire Down and Other Fire Ignition Causes Evaluation ..... 99

7.4 REFCL End User Questionnaire..... 102

8 SUMMARY ..... 107

9 REFERENCES..... 109

APPENDIX A: COST ESTIMATE DETAILS..... 110

## List of Figures

Figure 1-1. Test without REFCL Technology Enabled ..... 2

Figure 1-2. Test with REFCL Technology Enabled..... 3

Figure 1-3. Voltage Changes Following Line-to-ground fault on a REFCL-based System..... 5

Figure 2-1. SDG&E Grounding Layout for Descanso Substation..... 8

Figure 2-2. Swedish Neutrals REFCL Solution Container Design ..... 9

Figure 2-3. Connection of the Swedish Neutral REFCL Solution (Option 1 – with Zigzag) ..... 11

Figure 2-4. Connection of the Swedish Neutrals REFCL Solution (Option 2 – without Zigzag)..... 12

Figure 2-5. RCC Inverter Specifications as per Swedish Neutral ..... 14

Figure 2-6. REFCL Alternative 1 & 2 ..... 17

Figure 3-1. Measurements during Ground Fault in REFCL Application..... 19

Figure 3-2. Equivalent Circuit for ASC Grounded System ..... 20

Figure 3-3. Transient Currents for Ground Fault [16] ..... 22

Figure 3-4. Swedish Neutral Delta Admittance Method [15] ..... 23

Figure 3-5. Fault Clearing Strategy ..... 24

Figure 3-6. Advanced Fault Clearing Scheme ..... 24

Figure 3-7. Communication Links ..... 26

Figure 4-1. Synergi Model for Descanso Substation Displaying Circuits 73, 78 and 79 ..... 29

Figure 4-2. Synergi Model of Circuit 73: Individual Sections and Reclosers are Labelled Separately ..... 30

Figure 4-3. Synergi Model of Circuit 78: Individual Sections and Reclosers are Shown..... 31

Figure 4-4. Synergi Model of Circuit 79: Sections along with Reclosers are Shown Separately ..... 31

Figure 4-5. Values of Y and Z Matrices of Individual Conductors in the Synergi Model of Descanso Substation..... 32

Figure 4-6. Comparison of Y and Z Matrices Obtained from Synergi and MATLAB Code ..... 33

Figure 4-7. Synergi Model of Section 4 of C73 Showing Phasing of Conductors with Their Respective Length ..... 36

Figure 4-8. Synergi Model of Section 3 of C73 Showing Phasing of Conductors with Their Respective Length ..... 36

Figure 4-9. Synergi Model of Section 2 of C73 Showing Phasing of Conductors with Their Respective Length ..... 37

Figure 4-10. Synergi Model of Section 1 of C73 Showing Phasing of Conductors with Their Respective Length ..... 37

Figure 4-11. Synergi Model of Section 2 of C78 Showing Phasing of Conductors with Their Respective Length ..... 38

Figure 4-12. Synergi Model of Section 1 of C78 Showing Phasing of Conductors with Their Respective Length ..... 38

Figure 4-13. Synergi Model of Section 7E of C79 Showing Phasing of Conductors with Their Respective Length ..... 39

Figure 4-14. Synergi Model of Section 6E of C79 Showing Phasing of Conductors with Their Respective Length ..... 39

Figure 4-15. Synergi Model of Section 5E of C79 Showing Phasing of Conductors with Their Respective Length ..... 40

Figure 4-16. Synergi Model of Section 4E of C79 Showing Phasing of Conductors with Their Respective Length ..... 40

Figure 4-17. Synergi Model of Section 3E of C79 Showing Phasing of Conductors with Their Respective Length ..... 41

Figure 4-18. Synergi Model of Section 2E of C79 Showing Phasing of Conductors with Their Respective Length ..... 41



Figure 4-19. Synergi Model of Section 1 of C79 Showing Phasing of Conductors with Their Respective Length ..... 42

Figure 4-20. Synergi Model of Section 8W of C79 Showing Phasing of Conductors with Their Respective Length ..... 42

Figure 4-21. Synergi Model of Section 9W of C79 Showing Phasing of Conductors with Their Respective Length ..... 43

Figure 4-22. Synergi Model of Section 10W of C79 Showing Phasing of Conductors with Their Respective Length .... 43

Figure 4-23 Example of Phase Swap on an OH Lateral ..... 45

Figure 4-24. Section 4 Phase Swaps on C73 ..... 46

Figure 4-25. Section 3 Phase Swaps on C73 ..... 46

Figure 4-26. Section 2 Phase Swaps on C73 ..... 47

Figure 4-27. Section 1 Phase Swaps on C73 ..... 47

Figure 4-28. Section 2 Phase Swaps on C78 ..... 48

Figure 4-29. Section 1 Phase Swaps on C78 ..... 48

Figure 4-30. Section 7E Phase Swaps on C79 ..... 49

Figure 4-31. Section 4E Phase Swaps on C79 ..... 49

Figure 4-32. Section 3E Phase Swaps on C79 ..... 50

Figure 4-33. Section 2E Phase Swaps on C79 ..... 50

Figure 4-34. Section 8W Phase Swaps on C79 ..... 50

Figure 4-35. Phase Swaps and Additional Conductor on Section 4 of C73 ..... 52

Figure 4-36. Phase Swaps and Additional Conductor on Section 3 of C73 ..... 52

Figure 4-37. Phase Swaps and Additional Conductor on Section 2 of C78 ..... 53

Figure 4-38. Phase Swaps and Additional Conductor on Section 1 of C78 ..... 53

Figure 4-39. Phase Swaps and Additional Conductor on Section 3E of C79 ..... 54

Figure 4-40. Phase Swaps and Additional Conductor on Section 8W of C79 ..... 54

Figure 4-41. Flowchart of the Methodology to Size and Locate the Secondary Capacitor Banks ..... 58

Figure 4-42. Connection of a Secondary Capacitor Bank to Phase C of an OH Span ..... 59

Figure 4-43. Synergi Phasing of Area Including P172677 on C78 ..... 65

Figure 4-44. Google Street View at P172677 on C78 ..... 65

Figure 4-45. Equivalent Circuit for ASC Grounded System ..... 68

Figure 5-1. Dielectric Insulation Levels for Distribution Transformers [7] ..... 70

Figure 5-2. Electrical Insulation Characteristics of Transformer Bushings ..... 72

Figure 5-3. Insulator Insulation Levels [10] ..... 73

Figure 5-4. Overhead Recloser Ratings [11] ..... 74

Figure 5-5. Padmount Recloser Ratings [11] ..... 75

Figure 5-6. "Table 2" (Figure 5-4) Arrester Rating Selection ..... 77

Figure 5-7. "Table 8" [12] ..... 78

Figure 5-8. Extruded Dielectric Cable Terminations ..... 83

Figure 5-9. Laminated Dielectric Cable Terminations (1 of 2) ..... 84

Figure 5-10. Laminated Dielectric Cable Terminations (2 of 2) ..... 85

Figure 7-1. Probability of Sustained Ignition in Function of Time and Fault Current ..... 94

Figure 7-2. Percentage (%) of Ignition vs Non-Ignition Events for Main Ignition Drivers ..... 101

Figure 7-3. Percentage (%) of Ignition vs Non-Ignition Events for Vegetation Contacts ..... 102



## List of Tables

Table 2-1. Option 1 and Option 2 Substation Cost Estimates ..... 18

Table 4-1. Capacitance-to-Ground Values Calculated for Each of the Conductors Present in Descanso Substation ... 34

Table 4-2. Capacitance Values (in microfarads [μF]) for Different Sections of Descanso Substation in the Base Case 44

Table 4-3. Capacitance Values (μF) for Different Sections of Descanso Substation After Performing Phase Swaps .... 51

Table 4-4. Capacitance values (μF) for Different Sections of the Descanso Substation after Performing Phase Swaps as well as the Addition of Conductors ..... 55

Table 4-5. Different Configurations of Circuits on Descanso Substation ..... 56

Table 4-6. Base Case Before Installing Secondary Banks and After Installing Them (Solution 1) ..... 60

Table 4-7. Results of Phase Swaps Before Installing Secondary Banks and After Installing Them (Solution 2) ..... 61

Table 4-8. Results of Phase Swaps and Additional Conductors Before Installing Secondary Banks and After Installing Them (Solution 3) ..... 62

Table 4-9. Comparison of Three Solution Packages ..... 63

Table 4-10. Cost Estimate for Solution 1 and 2 of Capacitance Balancing ..... 64

Table 4-11. Allowed Length of Laterals for Fuse Operation for 1 OH and 1 UG Example of a 2-Phase Lateral in Three Cases (Phase AC, AB, or BC) in Solution 1 Package When All Sections are Energized ..... 66

Table 5-1. Estimated Costs for Overhead System Upgrades (includes 30% Contingency) ..... 80

Table 5-2. Cable Insulation Levels ..... 82

Table 5-3. Estimated Costs for Underground System Upgrades (includes 30% Contingency) ..... 86

Table 6-1. REFCL Activation Substation Bank Grounding Requirements ..... 88

Table 7-1. Key Benefits and Limitations of SDG&E Profile 3 Relaying Practice ..... 91

Table 7-2. Key Benefits and Limitations of SDG&E SGF Relaying Practice ..... 92

Table 7-3. Key Benefits and Limitations of SDG&E “Advanced” Ground Relaying Practice ..... 94

Table 7-4. Key Benefits and Limitations of SDG&E DFCEP Relaying Practice ..... 96

Table 7-5. Key benefits and limitations of SDG&E PPS practice ..... 97

Table 7-6. Key Benefits and Limitations of REFCL Technology ..... 99

Table 8-1. Option 2 and Solution 1 Summarized Costs (includes 30% Contingency) ..... 107



## ACRONYMS, INITIALIZATIONS, AND SYMBOLS

---

<b>ASC</b>	Arc Suppression Coil
<b>CBU</b>	Capacitor Balancing Unit
<b>CPUC</b>	California Public Utilities Commission
<b>DCC</b>	Distribution Control Center
<b>DER</b>	Distributed Energy Resource
<b>DFCP</b>	Distribution Falling Conductor Protection
<b>DTOC</b>	Definite Time Overcurrent
<b>GO</b>	General Order
<b>GOOSE</b>	Generic Object-Oriented Substation Event
<b>HIF</b>	High Impedance Fault
<b>IEC</b>	International Electrotechnical Commission
<b>IED</b>	Intelligent Electronic Device
<b>IEEE</b>	Institute of Electrical and Electronics Engineers
<b>IOC</b>	Instantaneous Overcurrent
<b>μF</b>	Microfarads
<b>PDC</b>	Phasor Data Concentrator
<b>P&amp;C</b>	Protection and Control
<b>PMU</b>	Phasor Measurement Unit
<b>PSPS</b>	Public Safety Power Shutoff
<b>RCC</b>	Residual Current Compensation
<b>REFCL</b>	Restricted Earth Fault Current Limiter
<b>SCADA</b>	Supervisory Control and Data Acquisition
<b>SGF</b>	Sensitive Ground Fault
<b>SRP</b>	Sensitive Relay Profile
<b>TOC</b>	Time Overcurrent
<b>VTs</b>	Voltage Transformers
<b>V<sub>o</sub></b>	Ground to Neutral Voltage
<b>WASA</b>	Wide Area Situational Awareness



# 1 INTRODUCTION

## 1.1 Study Purpose

The purpose of this Rapid Earth Fault Current Limiter (REFCL) study is to identify the requirements for implementing a REFCL scheme at the 69/12kV Descanso Substation, which feeds three 12kV circuits within the Tier 3 High Fire Threat District (HFTD) of San Diego Gas & Electric's service territory. This evaluation details the various electric infrastructure upgrades, new equipment installations, cost estimates, and operational impacts associated with implementing a REFCL scheme on a system that was never designed to do so. This report also draws comparisons to various system protection practices used for fire mitigation and details the pros and cons of each. The results provided are to be considered initial estimates since neither this practice nor the technology is currently widely utilized in the United States.

REFCL is currently being widely implemented in Australia and experimented on in the Western United States to reduce fire ignition risk as a result of energized line-to-ground faults. A line-to-ground fault can result from a phase conductor coming into contact with either a different phase conductor or a grounded object which may result in a wire-down event, an occurrence that has various causes. Some causes of a wire-down event can include high winds, vegetation contact, foreign objects, or equipment failure. REFCL is designed to significantly limit the ground fault current immediately after the line-to-ground fault occurs, which can reduce the risk of ignition. Figure 1-1 and Figure 1-2 provide a comparison test performed in Australia with and without the REFCL technology enabled.

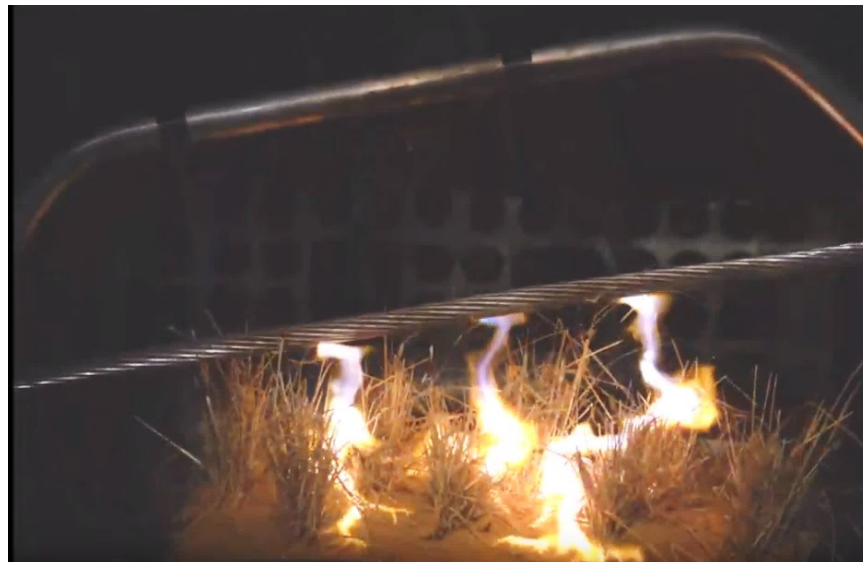


Figure 1-1. Test without REFCL Technology Enabled<sup>1</sup>

<sup>1</sup><https://www.youtube.com/watch?v=JCFQJFrVkSQ>



Figure 1-2. Test with REFCL Technology Enabled<sup>2</sup>

## 1.2 REFCL Concept Overview

Electric utilities in the United States have primary distribution systems that are normally wye-grounded at the source of the substation. SDG&E's distribution system is not the exception, as it was also built to be served by normally wye-grounded substation sources making its system effectively grounded. That substation transformer wye-grounding can be implemented as a solid connection to the ground grid or can be connected via an impedance between the wye connection and the ground. The ground impedance is installed to reduce the line-to-ground fault current. Depending on the utility, the distribution lines can serve either phase to phase connected load, or phase to neutral connected load if a properly grounded neutral conductor exists at the transformer location.

Unlike the United States, for over 100 years parts of Europe implemented its primary distribution system as ungrounded. Without the ground connection, there is a significant reduction to the line-to-ground fault current. The remaining line-to-ground fault current mainly results from line-to-ground capacitance on the distribution circuits. An early application, referred to now as a Resonant Grounded system, which further reduces the line-to-ground capacitance current, was implemented using a technology called a Peterson Coil. Implemented in the early 1900s, the Peterson Coil is an inductance placed between the substation transformer wye connection and ground. If the substation transformer is delta connected, a grounding bank is installed with the Peterson Coil connected at the wye. The Peterson Coil is sized to match the overall line-to-ground capacitance of the distribution circuits connected to the substation transformer, effectively canceling any resulting current associated with it.

<sup>2</sup> <https://www.youtube.com/watch?v=Q1MNBV48x0Q>



Additional technology has been implemented to quickly and significantly reduce the remaining fault current. Australia has been applying the REFCL concept using Swedish Neutral's Ground Fault Neutralizer (GFN) technology. The GFN technology monitors neutral to ground voltage in the substation. When the value exceeds established parameters, the GFN injects 180 degrees out of phase current to very quickly offset the fault current that does occur.

Following the 2009 Australian Black Saturday bushfires, the Victorian Government implemented multiple requirements to reduce the risk of future fires. One of those requirements was the installation of REFCL to rapidly limit the ground fault current when a line to ground fault occurs. One regulatory requirement is that the primary phase-to-ground voltage on the faulted conductor must be reduced to 250 volts within 2 seconds. This would reduce the phase-to-ground fault current to 0.5 amps or less.

Following are the performance requirements that the REFCL technology must comply with:

In the event of a phase to ground fault, the REFCL system shall have the following abilities:

1. Reduce the voltage on the faulted conductor in relation to the station earth when measured at the substation for high impedance faults (25,400 Ohms). The voltage must be reduced to 250 volts within 2 seconds; and
2. Reduce the voltage on the faulted conductor in relation to the station earth when measured at the substation for low impedance faults (400 Ohms) to-
  - i. 1900 volts within 85 milliseconds; and
  - ii. 750 volts within 500 milliseconds; and
  - iii. 250 volts within 2 seconds; and
3. During diagnostic tests for high impedance faults (25,400 Ohms), to limit-
  - i. fault current to 0.5 amps or less; and
  - ii. the thermal energy on the electric line to a maximum  $I^2t$  value of 0.10

Australia has been applying the REFCL concept using Swedish Neutral's Ground Fault Neutralizer (GFN) technology. The GFN technology monitors neutral to ground voltage in the substation. When the value exceeds established parameters, the GFN injects current to quickly offset the fault current that occurs. In Australia, Swedish Neutral has been selected as the primary vendor for this technology because, based on tests performed, it best meets the reduced fault current requirements.

### **1.3 Key Challenges with Implementation of REFCL**

Besides the work required to install the hardware for implementation at the substation, the REFCL application presents multiple challenges that are uncommon for United States electric utilities. Below are some of the key challenges that are foreseen and will be covered in this report.

- To implement the REFCL, the distribution system line-to-ground capacitance must be determined for the sizing of GFN equipment. Also, the line-to-ground capacitance must be very well balanced to maximize the ability to detect a line-to-ground fault.
- Once a line-to-ground fault occurs on the 12kV system, the fault detection utilized by the REFCL is based on the overall substation ground to neutral voltage shift, known as  $V_0$ . To identify and isolate





the faulted circuit, a new protection scheme must be implemented. The  $V_0$  detection and new protection schemes are available within the equipment cabinet provided by Swedish Neutral.

- Once a line-to-ground fault occurs, the faulted phase's line-to-ground voltage does go to zero, but the line to line voltage across all three phases remains. The challenge is that the un-faulted phases' phase to ground voltage increases to the nominal system phase to phase voltage. This is shown in Figure 1-3. The line-to-ground voltage increases during the fault require that some equipment be replaced to withstand that higher voltage.
- Circuits implemented with REFCL must have no phase to neutral connected load because there would not be an appropriately grounded neutral and is also a California General Order (GO) 95 and GO 128 violation.

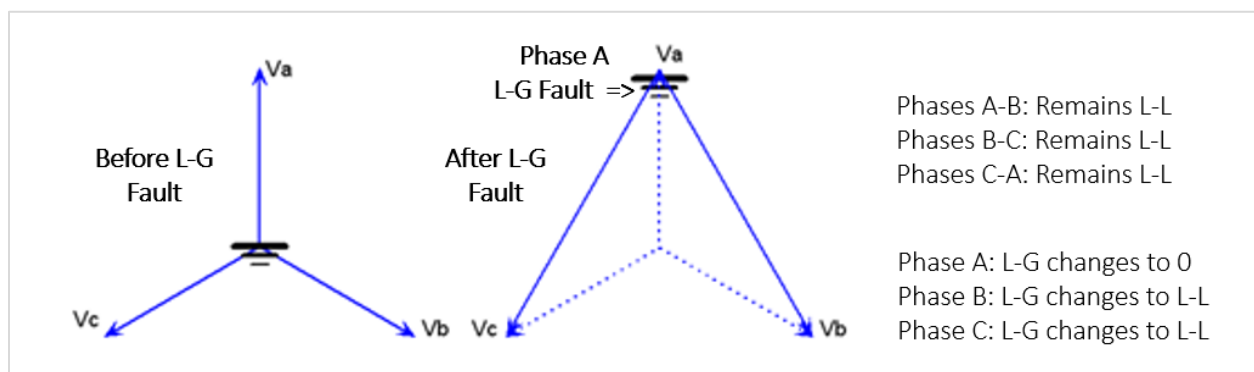


Figure 1-3. Voltage Changes Following Line-to-ground fault on a REFCL-based System



## 2 DESCANSO SUBSTATION

To properly implement REFCL, new equipment must be introduced and installed at the SDG&E Descanso Substation. This involves a Ground Fault Neutralizer (GFN) that includes an Arc Suppression Coil (ASC), Residual Current Compensation (RCC), and a REFCL control and monitoring system. Existing equipment was evaluated inside the Descanso Substation that would operate with the REFCL equipment.

This chapter will first review the existing substation equipment and outline whether it is suitable for the REFCL application. One of the major requirements evaluated is the voltage rating of the equipment. The phase to ground voltage during REFCL operation can rise by a factor of 1.73 during a fault. The second section will highlight the equipment that is needed for the REFCL installation at the substation, and the last part of the chapter will describe the new proposed substation layout and give a cost estimate of the required modifications, equipment evaluated, and findings.

### 2.1 Existing Equipment Evaluated

The first task was to review the as-built, existing power system equipment within Descanso Substation (some of which have been in service for over sixty years), and to investigate its operational ability during the time the proposed Swedish Neutral REFCL equipment is activated. A significant reason for this review was due to the Swedish Neutral REFCL technology having a different grounding philosophy than the grounding philosophy presently installed throughout the SDG&E power system.

The results of the review identify and suggest the replacement of any power equipment assets that may fail during the operation of the proposed REFCL system. In addition to the installation of the REFCL technology, further redesign and reworks are required to ensure safe and reliable operations of the new grounding philosophy within the substation.

According to SDG&E Drawing 980254, the Westinghouse main power transformer on the 12.47kV low side has 15kV rated bushings on X1, X2, and X3, along with 12kV rated lightning arresters. The MCOV rating of the 12kV lightning arresters has not been verified from SDG&E transformer drawings. Therefore, an assumption was made that the 12kV lightning arresters would have a 10.2kV MCOV rating. Lightning arresters with this MCOV class rating are typically used on effectively grounded power systems. However, given the age of the 12kV lightning arresters on the Westinghouse transformer a suggestion by SDG&E to replace these existing 12kV 10.2kV MCOV rated lightning arresters with new 15kV, 12.47 MCOV rated lightning arresters should provide full rated protection when the REFCL equipment is in operation.

Feeder circuits C73, C78, and C79 each have a Siemens 15.5kV vacuum circuit breaker rated at 1,200A with a porcelain bushing rated at 125kV BIL. Typically, rated maximum voltage 15.5kV bushing is 110kV BIL and 27kV bushings are 125kV BIL. However, since the Siemens bill of material on the vendor drawings states that the circuit breaker bushings at Descanso are 125kV BIL, then the maximum line-to-ground voltage these circuit breakers can withstand is 15.5kV when using 27kV as the line-to-line voltage. Therefore, there is no need to replace the bushings or modify the circuit breakers for use with new REFCL equipment.



Three Kuhlman bus potential transformers are rated 15kV, with primary operating voltage 12kV at 110kV BIL. The typical overvoltage rating is 110% continuously. These voltage transformers are, according to Kuhlman, primarily for line-to-line service. These potential transformers are connected wye grounded on both the primary and secondary. The bus potential transformers presently configured wye-grounded may be replaced with three single-phase PTs each with one primary winding and two secondary windings for wye and broken delta. The broken delta windings provide the zero-sequence voltage source for the Swedish Neutral REFCL equipment.

A single-phase 10kVA substation service transformer is noted as 12kV and is connected line-to-ground. According to [7] the induced line-to-ground test voltage for this transformer type is 17kV. There is no need to replace this transformer due to the addition of new REFCL equipment. However, the 10kVA station service transformer is slated to be replaced by SDG&E with a single-phase 25kVA transformer to add more capacity for future growth within the substation control shelter.

A three-phase 13.2kV Voltage Regulator, Siemens Type SFR is noted on SDG&E drawing DWG DE-E-41. This three-phase voltage regulator is connected in a 13.2kV wye configuration, this voltage is the maximum design voltage or nominal single-phase line-to-ground voltage. Typically, a three-wire-based regulator voltage rating can be either 13.8kV or 14.4kV according to [2].

The 3000kVar Capacitor Bank shown on the one-line drawing has been isolated and taken out of service, so it will not affect the operation of the REFCL equipment.

Auxiliary-services equipment inside the substation was assessed to ensure that all existing AC/DC distribution system equipment could accommodate the AC (“Alternating Current”) and DC (“Direct Current”) load growth caused by the new Ground Fault Neutralizer (“REFCL”) package and new relaying equipment. The following auxiliary-service equipment was evaluated:

- AC switchboard (rating and circuit availability); not affected
- DC switchboard (rating and circuit availability); not affected
- Battery system and charger; not affected

A new grounding study of the entire substation which includes both upper and lower yards will need to be performed per SDG&E’s substation grounding design standard (SES-5401). A final grounding report with the appropriate changes that are necessary to comply with IEEE 80 and 81 will be developed based on this study.

Figure 2-1 presents the grounding layout for Descanso Substation.

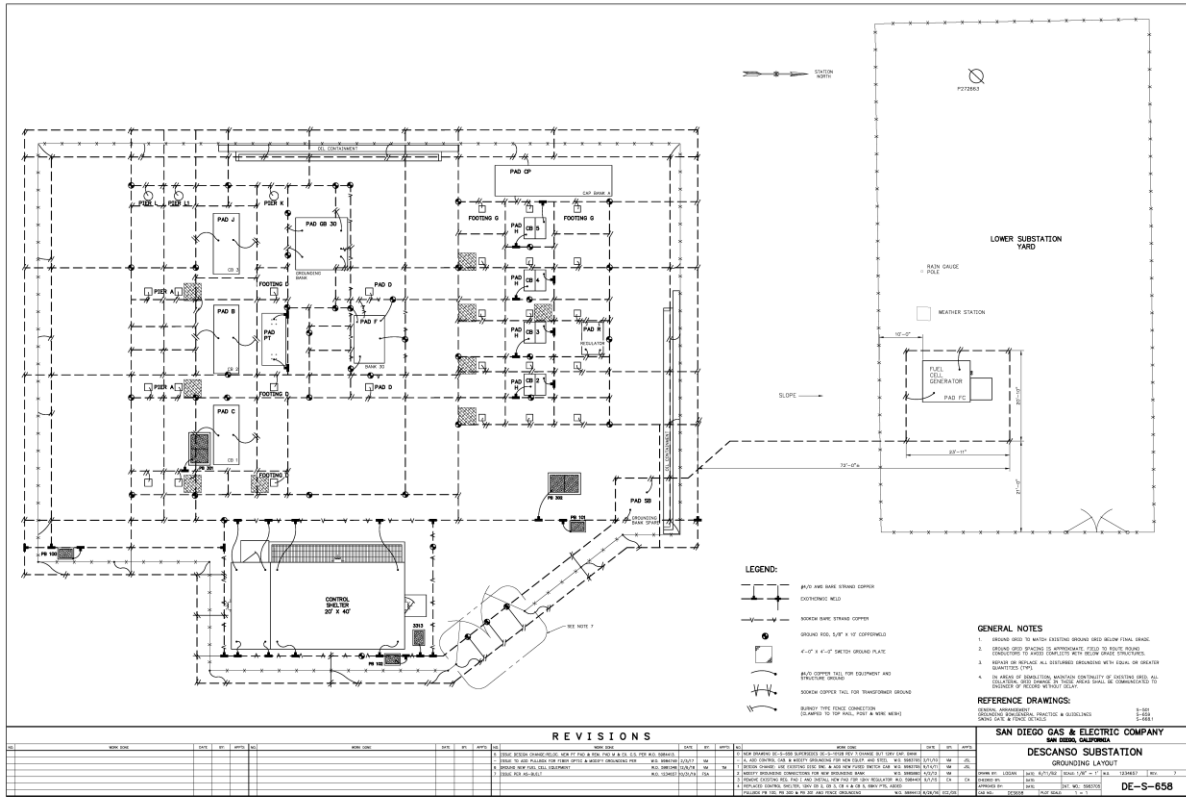


Figure 2-1. SDG&E Grounding Layout for Descanso Substation

## 2.2 New Equipment Evaluation

The implementation of the REFCL solution will require new equipment to be installed within the substation. The core elements that need to be installed are an Arc-Suppression Coil (ASC) and a Residual Current Compensator (RCC) with their associated control devices. At this time Swedish Neutral has the longest history in providing such solution packages and is the only fire mitigation solution approved by Australian electric utilities. Therefore, Swedish Neutral is used as a reference to evaluate the implementation of a REFCL solution for the SDG&E Descanso Substation.

### 2.2.1 Swedish Neutral REFCL Container

Swedish Neutral offers a self-contained, fully-equipped container (see Figure 2-2) that only requires the connection of the system bus voltage, the feeder current measurements, and the station 12kV neutral to the container.



This container includes the following components:

- Arc Suppression Coil (ASC)
- Arc Suppression Coil Tuning Components
- Residual Current Compensator (RCC)
- Ground Fault Neutralizer Control
- Grounding Transformer (Optional if no 12kV source ground reference is present)

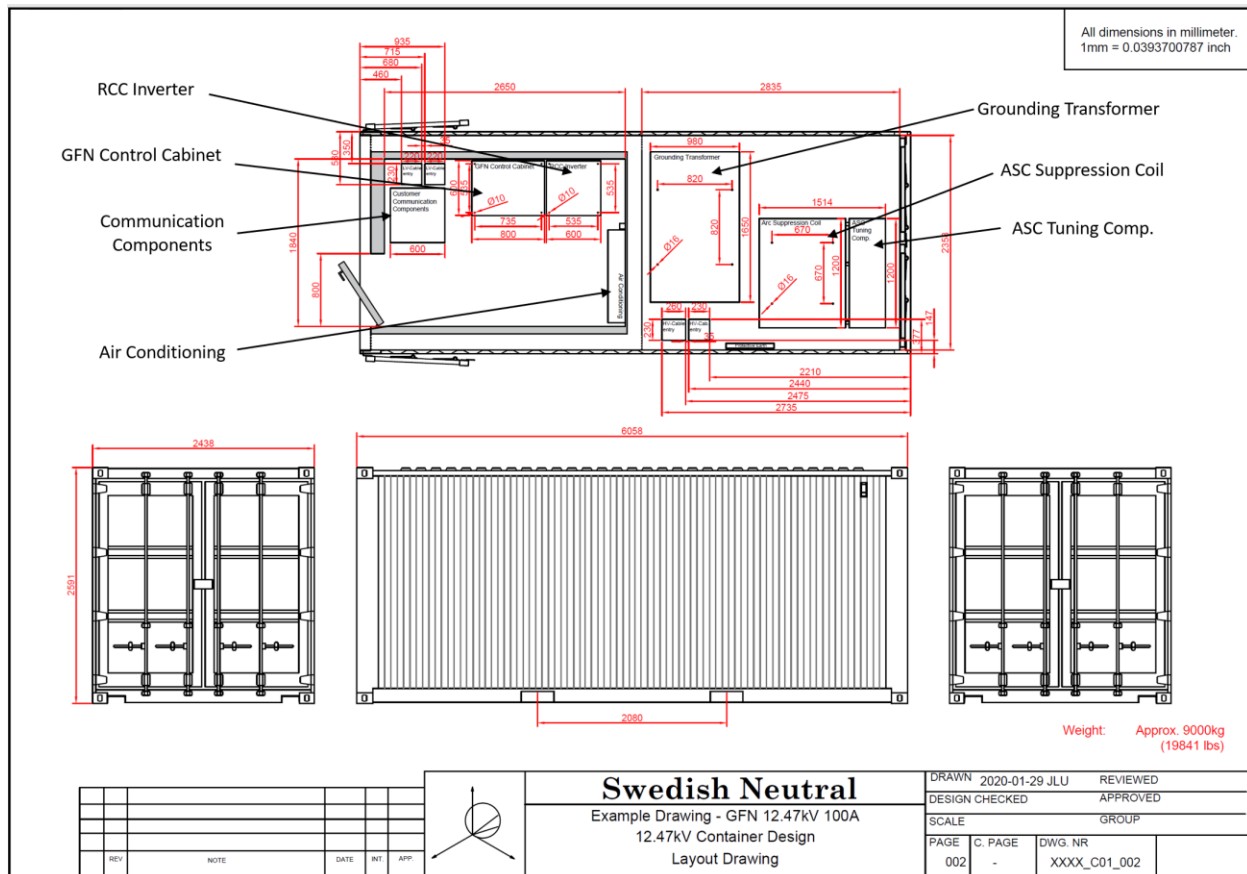


Figure 2-2. Swedish Neutrals REFCL Solution Container Design

The system neutral can be provided via a zigzag transformer included in this solution. Its internal zigzag transformer is connected to the substation 12kV bus which provides station service for the container.

The ASC is connected between the zigzag transformer neutral and the station ground. The tuning of the coil is performed via capacitors that are switched in and out and connected in parallel to the ASC via an internal transformer. The same transformer is used to inject the residual compensation current from the



RCC to the circuit. Included in this solution are PTs and CTs, for the measurements of  $I_0$  and  $V_0$ . The GFN controller provides the following functionality:

- Controls and tunes the ASC reactance
- Controls the residual current injection
- Determines faulty circuit based on transient measurements
- Determines fault circuit based on admittance principal

The self-contained solution is ideal for delta applications where the REFCL scheme provides the grounding method. At this time Swedish Neutral does not offer a solution that would allow switching between a wye-grounded system operation and REFCL grounded operation as part of the self-contained solution. SDG&E is considering only activating the REFCL grounding method during a high fire risk situation and would like to have the option to operate the system in the traditional grounded mode during the off-fire risk season.

This will require the installation of an external 15kV single-phase recloser that can connect or disconnect the transformer neutral to/from the station ground. This identifies when the REFCL scheme should be disabled and the system should be operated as a traditional grounded system. The fact that additional installation work must be performed on the station transformer neutral makes the advantage of using the provided zigzag transformer for grounding in the Swedish Neutrals solution questionable. This report will discuss two options for installation of the REFCL: Option 1 (see Figure 2-3) provides for a fully equipped container housing the 12kV zigzag and voltage transformers, and Option 2 (see Figure 2-4) requires external 12kV, 400Y/230 volt station service and 12kV voltage transformers.

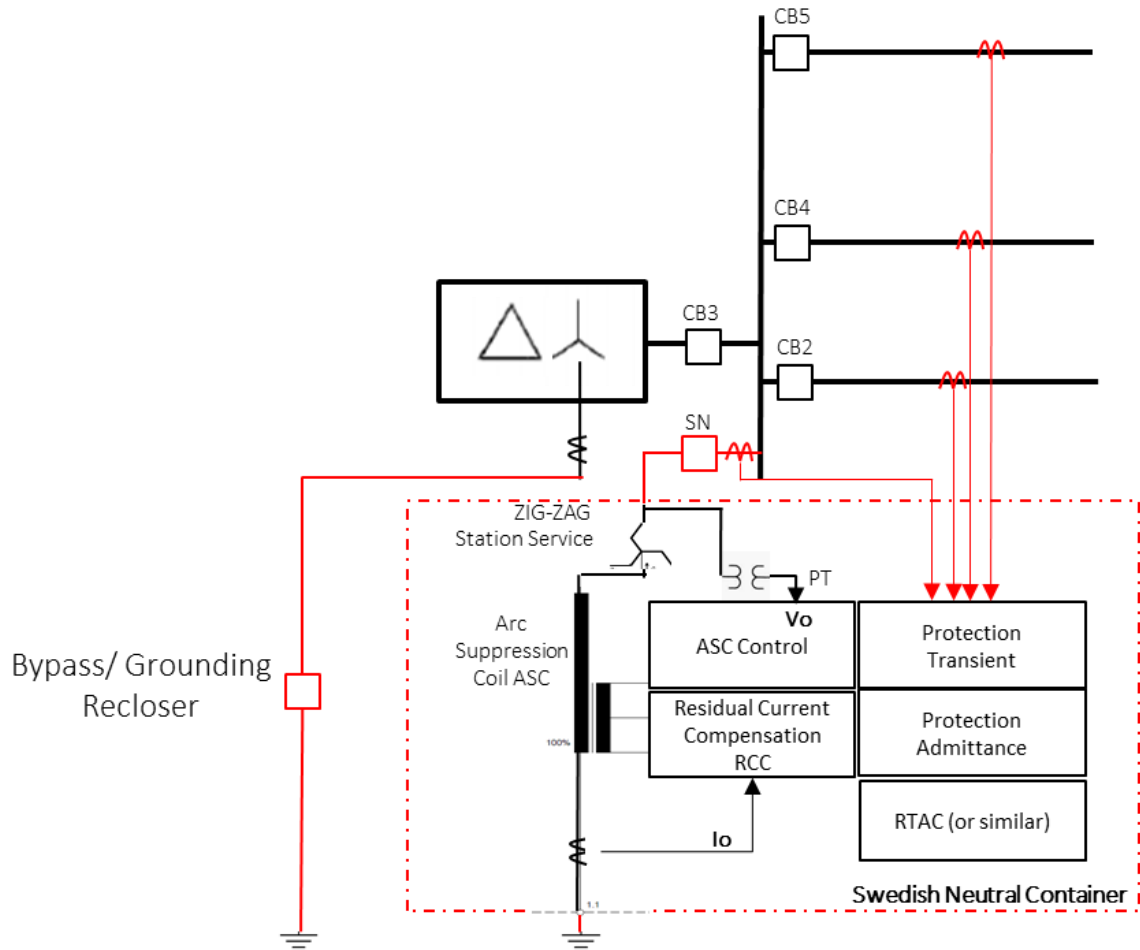


Figure 2-3. Connection of the Swedish Neutral REFCL Solution (Option 1 – with Zigzag)

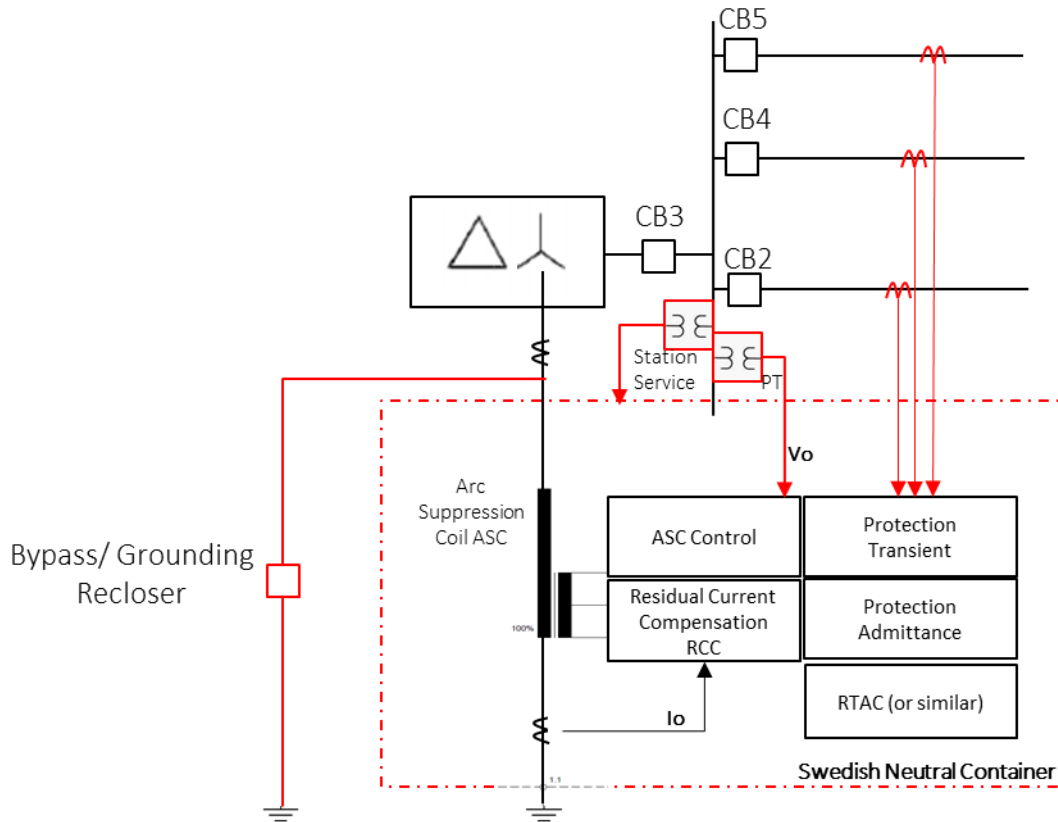


Figure 2-4. Connection of the Swedish Neutrals REFCL Solution (Option 2 – without Zigzag)

Before the two options are compared, the requirements of all components common for both options must be discussed.

### 2.2.2 Arc Suppression Coil (ASC)

The core element in reducing the capacitive current during a ground fault is the arc suppression coil (ASC). The purpose of the ASC is to compensate the capacitive current of the system so that the fault current at the fault location is reduced to theoretical zero values, with some amperes remaining that are the result of resistive losses in the system. The sizing of the ASC is determined by the capacitance of the system that is connected to the transformer on which the ASC is installed. The value is specified as an ampere value and calculated with Equation 2.1:

$$I_{ASC\_min} = \sqrt{3} * V_n * \omega * C_g$$

[Eq. 2.1]





Where:

$I_{asc\_min}$ : Minimum current rating for ASC

$V_n$ : Nominal system voltage (phase to phase)

$\omega$ : angular frequency ( $2 \cdot \pi \cdot 60$  Hz)

$C_g$ : System ground capacitance

For the Descanso circuits, it was determined the system capacitance based on the Synergi model should be a value of approximately  $3.7 \mu\text{F}$ . With this value, the ASC must at a minimum be able to compensate approximately 29A. A 20 % margin should always be used to accommodate for errors in the model and possible future extensions. Based on SDG&E distribution planning feedback, an even higher margin may have to be considered. Swedish Neutral offers its solution in two different sizes of 50A or 100A. The 50A solution seems sufficient enough for the Descanso circuit, but the 100A variant could be also be considered since there is not a large price difference.

The tuning range of the reactance value is from 10 to 100%. If the minimum required value is below 10A, the 50A variant must be selected what will allow a minimum value of 5A compensation.

### 2.2.3 Residual Current Compensator (RCC)

The residual current compensator must be dimensioned so it can inject a current into the circuit having the same value but is in phase opposition to the residual current produced by the resistive losses of the circuit. The resistive losses are caused by surge arresters and the ASC.

The value typically is in the range of 2–10% of the current value of the ASC. In this example, the worst-case scenario would require the injection of 10 A at 6.9kV and require 69kW.

Swedish Neutral provided (see Figure 2-5) that the RCC inverter can provide 800A at 400V = 320kW and is sufficient for the Descanso circuit.

The HVAC system in the container is adequate to absorb the heat development of the RCC that could develop during a ground fault.



<b>Voltage</b>	400V AC
<b>Current</b>	Up to 800A (Connection of parallel RCC Inverters possible)
<b>Duty</b>	Continuous operation
<b>Cooling methods</b>	Air
<b>Frequency</b>	50 or 60 Hz
<b>Installation</b>	Indoor
<b>Insulation level</b>	According to the rated voltage (IEC70076-3)
<b>Ambient temperature</b>	Indoor
<b>Auxiliary voltage</b>	400 V AC 3-phase
<b>Insulation level (control equipment)</b>	>1 kV 1 s ( IEC 60204-1:1997)
<b>Dimensions</b>	According to project specification

Figure 2-5. RCC Inverter Specifications as per Swedish Neutral

#### 2.2.4 Metering Current Transformers

For the faulted circuit identification, the zero-sequence current on each feeder must be measured. The Swedish Neutral detection principles do not require high accuracy and therefore the sum of the three-phase measurements (Holmgren circuit) can be used for the zero-sequence current measurements. The admittance principle relies on the detection of an admittance change and can eliminate the error caused by the different phase CTs. The second principle used in the Swedish Neutral solution evaluates the first transients caused by the charging and de-charging of the different feeders to detect the faulty circuit.

The currents measured for this application are in the range of load currents even during a single phase to ground fault. Therefore, metering CTs were selected for this purpose with an accuracy class of 0.15 installed at each feeder breaker in the substation.

#### 2.2.5 Grounding Breaker/Switch

SDG&E wants to have the option to activate and deactivate the REFCL scheme based on the fire risk situation. The deactivation would include the solid grounding of the transformer neutral. As this possibility is not provided by the Swedish Neutral solution, the grounding breaker/switch must be installed in addition to the Swedish Neutral Container. For this evaluation, a 15kV G&W Viper-SP Single-Pole Recloser, G&W Relay, with Polymer Arresters, Conduit, Control Cables is considered.

#### 2.2.6 Specific Equipment for Option 1

Option 1 utilizes the Swedish Neutral container to its fullest and utilizes the internal zigzag transformer to provide a neutral that is connected to the ASC. The zigzag transformer will also provide the station service for the container. All measurements for  $I_0$ ,  $V_0$ , and bus voltages are provided on the inside of the container. Only a connection to the 12kV bus voltage is needed along with the measurements from the individual circuits provided by metering current transformers.



### **2.2.6.1 Protection Current Transformers**

Any phase-to-phase fault on the feeder that connects the Swedish Neutral Container with the station bus (Option 1) needs to be detected and isolated from the system in coordination with the remaining protection. This is implemented with a new breaker and associated feeder protection relays.

Protection CTs must be used for this installation as the fault currents can have multiple of the load current. The actual protection of the feeder is planned to be performed with a phase overcurrent function. Also, the measured feeder current is needed by the bus differential relay so that a feeder fault would be seen as an external fault and not operate the bus protection. The CT's are integrated into the 15kV Three-Phase Siemens, Vacuum Circuit Breaker.

### **2.2.6.2 Feeder Breaker**

If the Swedish Neutral Container is connected to the station bus (Option 1), a new feeder breaker must be installed that is capable of interrupting the maximum bus fault current. For this evaluation, a 15kV Three-Phase Siemens, Vacuum Circuit Breaker, Type SDV7-SE, 15.5kV, 1200 Amps, 6-1200/5A MRBCTs that have the protective relays included is considered.

### **2.2.7 Specific Equipment for Option 2**

In Option 2, the ASC inside the Swedish Neutral container would be connected directly to the transformer neutral. The zigzag transformer would not be utilized and a high voltage connection to the 12kV bus would not be required.

#### **2.2.7.1 Station Service Transformer**

In Option 2, the station service must be provided separately. The station voltage needed for the container is 400Y/230 volts. A total of 150 kW is estimated as load. For this evaluation, three single-phase pole-type transformers for the Swedish Neutral REFCL Container Station Service are considered.

#### **2.2.7.2 Voltage Measurements**

The GFN controller needs the measurements of zero-sequence voltage  $V_0$  and the three-phase 12kV voltages. Option 2 will require that new 12kV PTs be installed on the 12kV station bus. For both voltage measurements, it is proposed to install bus PTs with three windings. (One primary and two secondary) The primary windings will be connected wye grounded. One set of secondary windings will be wired wye grounded for three-phase voltage measurement, while the other secondary windings will be wired in a broken delta to measure the zero-sequence voltage  $V_0$ .

## **2.3 Layout Evaluation and Findings**

Descanso Substation is a 69/12kV substation located at the intersection of Oak Grove and Boulder Creek Road in Descanso, California. Descanso is a small one-transformer 69/12kV substation built over 60 years ago covering 0.36 acres and approximately 512 feet of 10-foot fencing. It has three (3) 69kV transmission lines, one (1) 69kV grounding transformer, one 6.0/7.0 MVA power transformer bank, three 12kV single-phase bus voltage regulators, and three 12kV distribution feeder circuits. A new control shelter was recently installed, and an old control shelter building is to be removed.



The substation has two fenced substation yards, the upper, and lower. The upper substation yard contains the main substation key power equipment, 69kV and 12kV steel structures, a new control shelter, and a 40ft by 20-ft area reserved for an emergency portable transformer. In the 2016/2017 timeframe, the lower substation yard was built for a new Fuel Cell Generator. This lower substation yard is approximately 50 feet north of the main substation yard and occupies approximately 0.17 acres with a fenced perimeter of ~360 feet.

The upper substation yard has limited physical space for the installation of additional equipment due to the access requirements for construction, maintenance equipment, vehicles, and for the emergency installation of the mobile substation. The lower substation yard has physical space but is located an average of twice the distance of the upper substation yard – or, more than 100 feet from the substation control shelter, 69/12kV power transformer, and 12kV circuit breakers. This yard also drops about 15 feet in elevation from the main substation yard.

Based on an on-site visit, it was determined there are two alternatives for the placement of the Swedish Neutral REFCL GFN system. The first alternative is on the west side of the main power transformer where an existing 69kV zigzag grounding bank presently resides, and the second alternative is in the lower Fuel Cell Generator yard. Several other alternatives were also considered for the upper substation yard including the space vacated by the substation capacitor bank, a space in the northeast corner near the substation main entrance gate, and the lower substation yard. It was felt that the capacitor bank space did not provide adequate room for operational purposes and required fence separation, the northeast corner also had fencing issues and possible interference with the emergency installation of the mobile transformer. SDG&E was considering the removal of the 69kV grounding transformer and its location was considered a prime location. SDG&E decided the grounding transformer was no longer needed and could be removed. Its physical location was considered the best alternative for installing the new Swedish Neutral REFCL equipment. The two top alternatives considered are shown in Figure 2-6.

With the removal of BK30G and verification that electrical clearances are adequate for installing the GFN container, the BK30G's vacated physical space is the first choice or alternative for the Swedish Neutral REFCL equipment. Alternative 1 allows installation within the existing substation fence. Therefore, the substation fence or oil containment system does not need to be modified and a substation fence cost estimate is no longer required. However, a transformer firewall is required between BK30 and the GFN container and is shown in Figure 2-6.

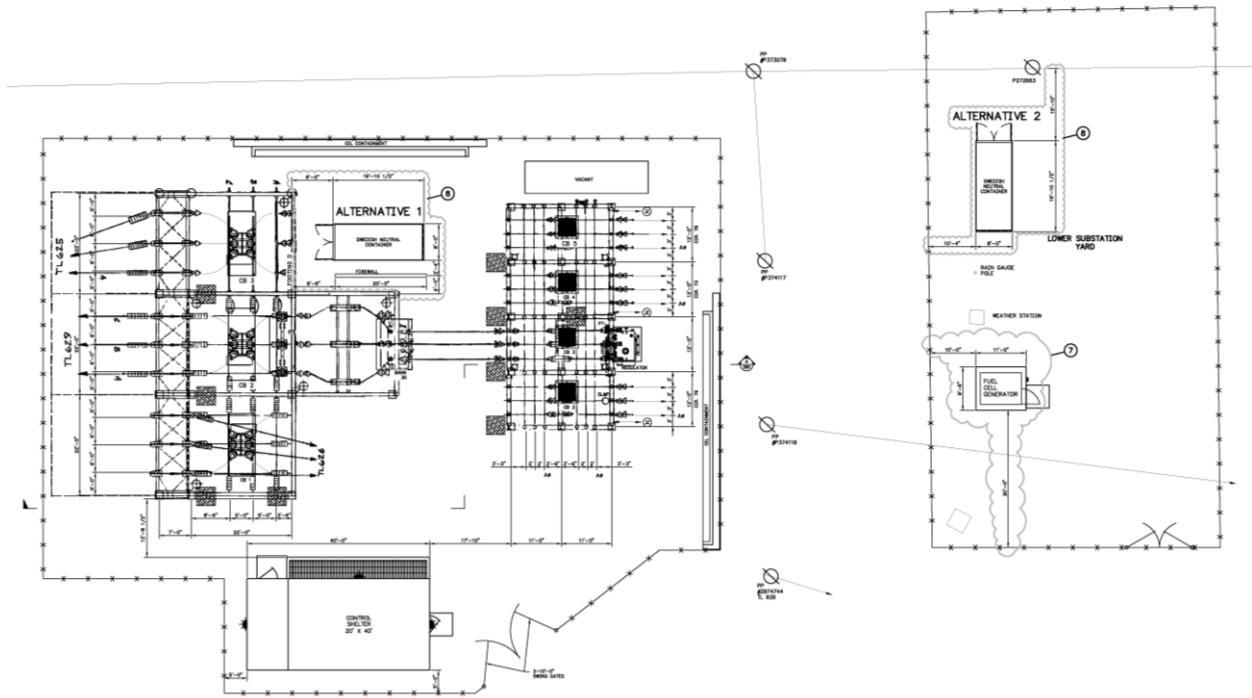


Figure 2-6. REFCL Alternative 1 & 2

## 2.4 Estimated Substation Cost Options

High-level cost options are shown in Table 2-1 detailing the primary equipment and costs associated with Option 1 and Option 2 for the Swedish Neutral container when supplied with and without the grounding transformer and MV voltage transformers, respectively.



**Table 2-1. Option 1 and Option 2 Substation Cost Estimates**

Item Description	Quantity Option 1 (incl. zigzag)	Quantity Option 2 (w/o. zigzag)	Cost Option 1	Cost Option 2
REFCL Swedish Neutral Container	1 (w grounding)	1 (w/o grounding)	\$1,150,000	\$1,115,000
15kV G&W Viper-SP Single-Pole Recloser	1	1	\$7,500	\$7,500
15kV Transformer Lightning Arresters	3	3	\$5,400	\$5,400
15kV Class 110kV BIL, 600:5, class 0.15, Bushing Type CTs	12	9	\$30,000	\$22,500
Set of 3-Phase Fused Disconnect Switches for 3-Phase SL&P Transformer and Bus VTs	0	2	\$0	\$6,800
Pad-mounted or OH Pole Transformers 12470-400Y/230V for SN REFCL Container Station Service	0	3	\$0	\$24,600
15kV Bus VTs w/3 Windings Y and Broken Delta for Swedish Neutral REFCL Zero-Sequence Voltage Sensing	0	3	\$0	\$18,000
15kV Three-Phase Siemens, Vacuum Circuit Breaker, Type SDV7-SE, 15.5kV, 1200 Amps, 6-1200/5A MRBCTs that has the protective relays included	1	0	\$26,237	\$0
New Swedish Neutral REFCL Container Foundation	1	1	\$18,400	\$18,400
Net Cost to include capacitor balancing, equipment replacements, contingency, overheads, and Owner's Work	0	0	\$2,589,895	\$2,287,007
		<b>TOTAL</b>	<b>\$3,827,432</b>	<b>\$3,505,207</b>



### 3 EXISTING RELAYING EQUIPMENT EVALUATION AND UPGRADES

The use of REFCL technology targets to eliminate the fault current resulting from phase-to-ground faults. This will impact the classical ground fault protection that relies on the detection of significant fault current to detect such faults. This chapter will discuss the challenges and changes that the deployment of the REFCL technology has for system protection.

#### 3.1 General Protection Considerations

The classical ground fault protection for grounded networks is based on the detection of ground currents. In an ideal radial distribution system, all relays in the path from the source down to the fault location will measure the same ground fault current. Based on time coordination the relay/recloser that closes to the fault location will operate and selectively clear the fault based on the relay time-current characteristics.

#### 3.2 Ground Over Current Based Fault Detection

With the use of the REFCL technology and the special treatment of the neutral grounding of the transformer, the existing ground fault protection can no longer reliably detect and clear a ground fault because the resulting ground fault current will no longer reach the pickup values set in the relays for detection. This is because the ground current magnitude measured by all relays and reclosers in the system is much lower and is determined by the capacitance of the downstream circuit. As shown in Figure 3-1, the measurement of the ground current by the devices on the system is not dependent on the fault location but based on the location of the device and the circuit components connected downstream.

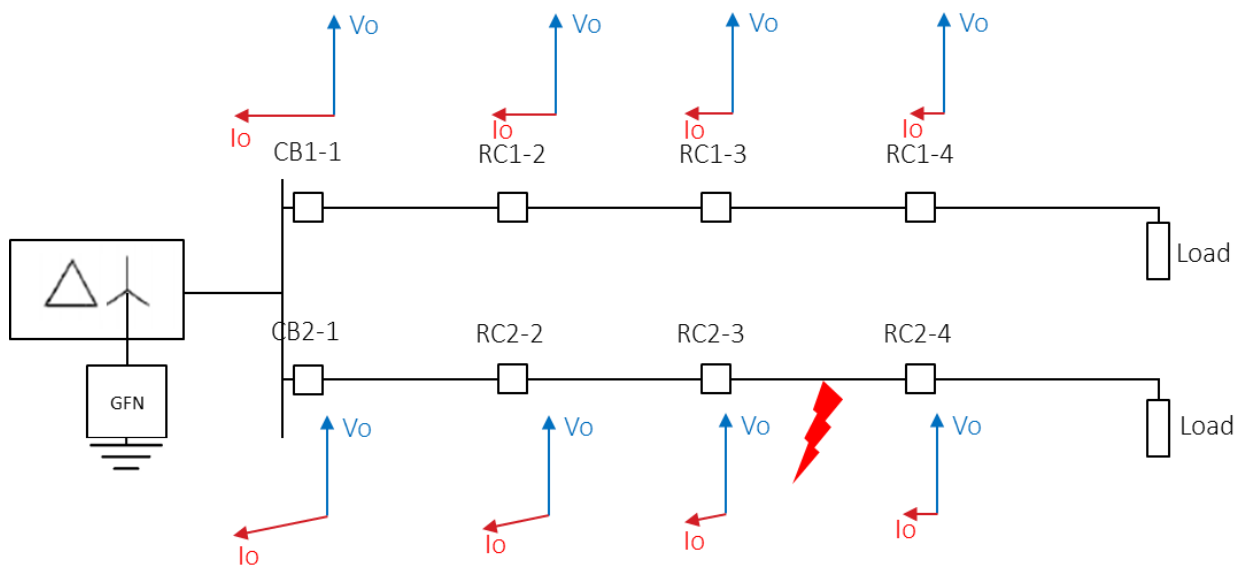


Figure 3-1. Measurements during Ground Fault in REFCL Application



As all relays in the system could respond to a ground fault, a selective time coordinated fault clearing is not possible anymore. Based on this, the existing ground protection in the substation and the feeder devices must be disabled while the system is grounded via the REFCL application.

As the selected transformer grounding method does not have any influence on phase to phase faults or 3-phase faults, the existing phase protection can be utilized independently from the grounding method.

### 3.3 Ground Fault Clearing with REFCL

The detection and selective fault clearing of ground faults on systems with REFCL neutral grounding present a challenge, as the ground current cannot easily be used for this purpose. There are different solutions used to find and remove a ground fault in such systems. All solutions are based on fault detection and fault direction determination.

#### 3.3.1 Ground Fault Detection

The detection of a ground fault on a REFCL-based system is done by monitoring the zero-sequence voltage  $V_0$ . Under the normal symmetrical operating condition, the  $V_0$  voltage is close to zero. A rise in  $V_0$  above a certain threshold is used for the detection of ground faults. The level must be selected at a value that cannot be reached based on asymmetries of the system that will cause a residual  $V_0$  voltage also during normal operations. The sensitivity of the fault detection determines the requirements on the system symmetry. Figure 3-2 shows a simplified representation of a circuit that can be used to determine the  $V_0$  voltage based on asymmetries caused by unequal capacitance in different phases ( $\Delta C$ ) or fault a resistor ( $\Delta R$ ).

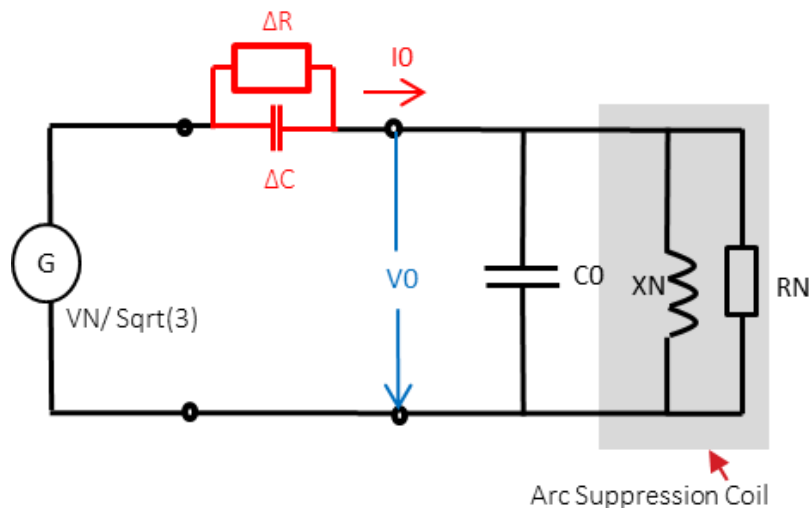


Figure 3-2. Equivalent Circuit for ASC Grounded System





If for example the voltage level to detect a ground fault should be set to 3 times the value that can be measured under normal operating conditions, then the allowed system asymmetry can be calculated as:

$$1/\omega\Delta C < 3*\Delta R \quad \text{Eq. 3-1}$$

Where:

$\Delta C$ : capacitive asymmetry in the system

$\Delta R$ : resistive asymmetry caused by fault resistor

$\omega$ : angular frequency ( $2*\pi*60$  Hz)

The Australian regulation requires that the REFCL scheme must be able to detect fault resistance up to 25.4 kOhm. Based on this requirement, the system cannot have a larger capacitive unbalance in the phases as:

$$\Delta C = \frac{1}{\omega*3*\Delta R} = 0.0348 \mu F \quad \text{Eq. 3-2}$$

The distribution system may have to be balanced for this reason. This is discussed in more detail in Section 4 of this report.

$V_0$  can be measured anywhere in the system, therefore any protection device that is called onto responding to a ground fault can use the detection of  $V_0$  as a trigger to start processing the fault values.

### 3.3.2 Ground Fault Direction

The second task is to determine the fault direction. Based on this information, the faulted circuit and even the faulted section can be identified. There are many solutions used and proposed to determine the fault direction for ungrounded or compensated networks. The evaluated solution from Swedish Neutral provides two independent methods for this purpose that will be explained further in this report.

#### 3.3.2.1 Direction Determination based on Transient Currents

A ground fault on systems that are isolated or grounded via Arc Suppression Coils (ASC) will cause a transient charging current on the healthy circuit and a transient discharging current on the faulted circuit. These transients are evaluated to detect the faulted circuit.

In Figure 3-3 there are transient charging and discharging currents shown in relation to the zero-sequence voltage  $V_0$ . All healthy circuits will show the first current transient in phase with the  $V_0$  voltage and the faulted circuit will show the current peak in phase opposition to the  $V_0$  voltage.

This method provides good results on a large circuit where the transient currents have sufficient amplitudes to be used for the detection. On short circuits and faults with high fault resistance, such as those associated with high impedance faults (HIF), the first current peaks may be too small to securely be used for this direction determination.

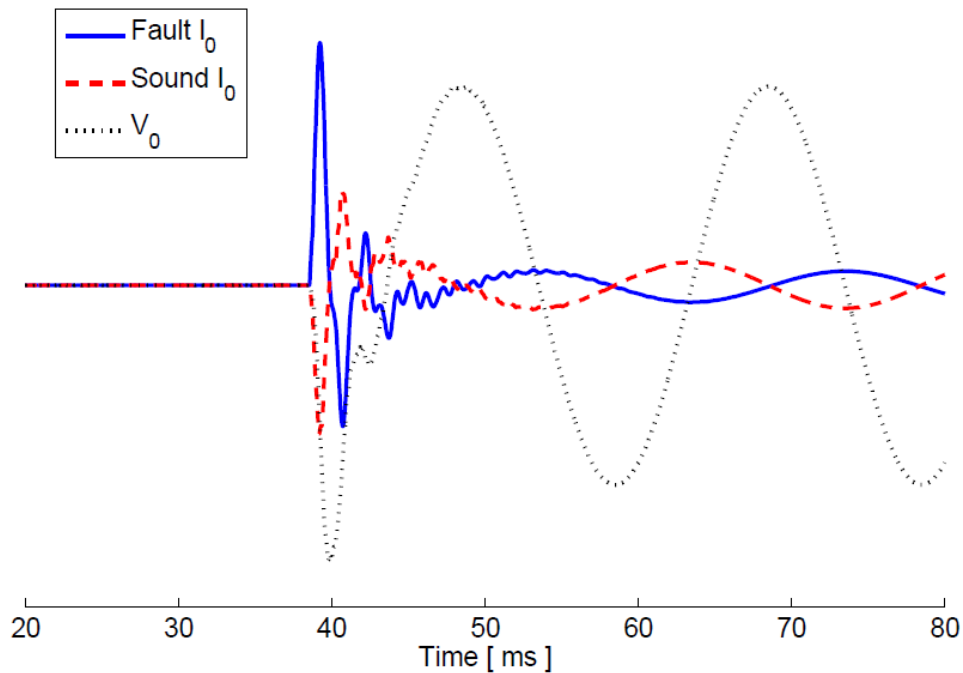


Figure 3-3. Transient Currents for Ground Fault [16]

### 3.3.2.2 Direction Determination Based on Zero-Sequence Admittance Method

The second method used by the Swedish Neutral solution is based on the measured circuit admittance during the fault. It is triggered by the detection of the  $V_0$  voltage.

This method (see Figure 3-4) is using the delta of the admittance based on the adjustment of the ASC during the fault. Only the faulted feeder will show a change in the admittance as only the faulty feeder has the ASC included in the admittance. All other circuit admittances will not change when the ASC value is changed. Swedish Neutral claims that this method has the following advantages:

- Works independently of arc suppression coil mismatch
- Differential scheme - eliminates CT and VT errors
- Highly sensitive fault detection

Swedish Neutral confirmed that the use of phase CTs connected in a Holmgren circuit to measure  $I_0$  is sufficient for this application and no special core balanced CTs are required.

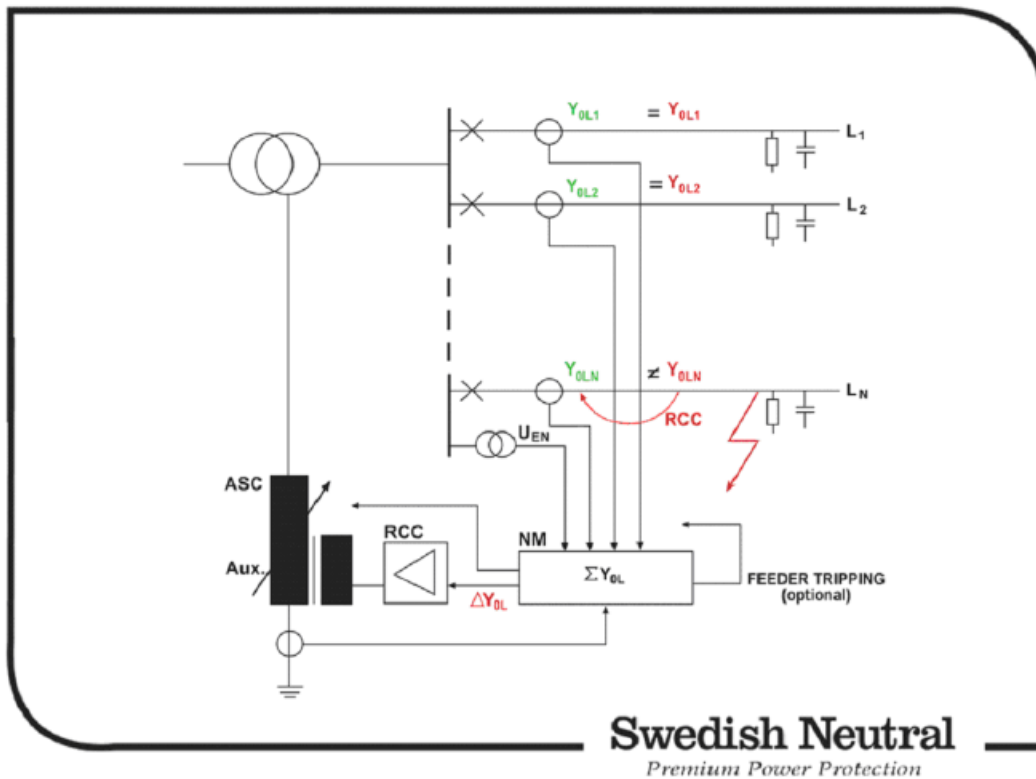


Figure 3-4. Swedish Neutral Delta Admittance Method [15]

### 3.3.3 SDG&E's Ground Fault Clearing Strategy

With the previously described tools for fault detection and direction determination, different fault clearing strategies can be developed. The different strategies differ based on the requirements for fault clearing time, selectivity, and effort to implement.

For the evaluation of this report, SDG&E proposes for fault clearing to trip the circuit breaker in the substation after the faulted circuit detection is identified. This solution utilizes the method Swedish Neutral provides to identify the faulted circuit and uses this information to operate the faulted circuit breaker. It requires transmitting the trip information from the Swedish Neutral Container into the control shelter where the circuit breaker trip logic exists and needs to be modified. The scheme can trip the circuit without intentional delay and therefore provides an advantage regarding fire mitigation as the shorter fault duration will reduce the likelihood of fire ignition.

The disadvantage of this solution is that the fault is cleared unselectively. In the example shown in Figure 3-5, it would be desirable only with respect to the selectivity to trip only recloser RC2-3 for the fault shown.

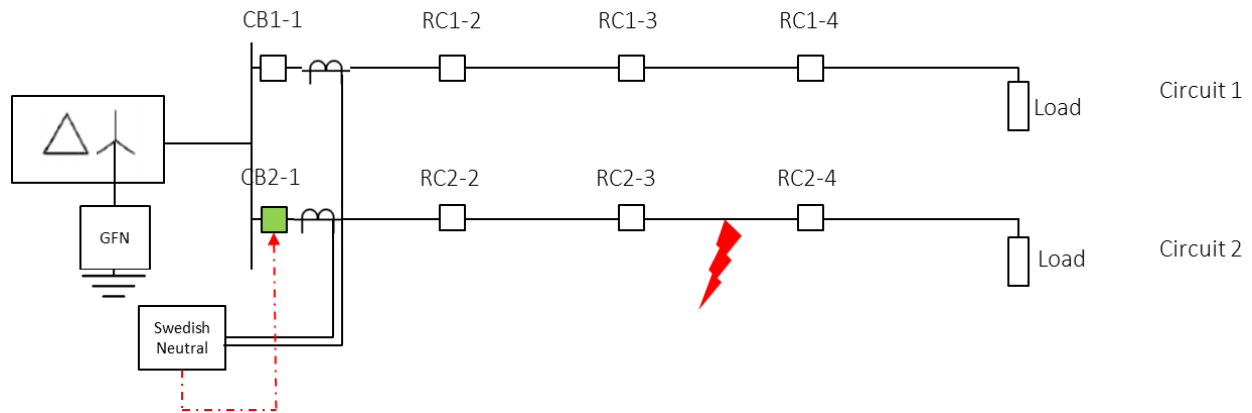


Figure 3-5. Fault Clearing Strategy

A more advanced scheme considered by SDG&E (Figure 3-6) can eliminate the disadvantage of an unselective fault clearing. In this scheme, all relays and reclosers will use  $V_0$  for the detection of a ground fault and start a coordination timer. The faulty circuit identification performed by the Swedish Neutral devices inside of the substation is used as a permission signal and send to all relays and reclosers on the faulty circuit.

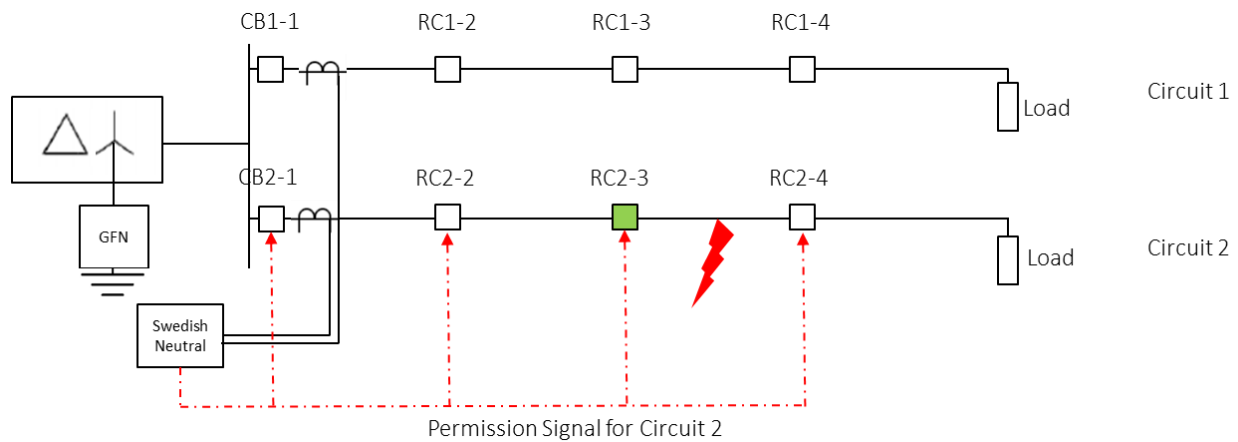


Figure 3-6. Advanced Fault Clearing Scheme

The timers in the relays are set in a way that the reclosers on the end of a circuit will time out fastest. Each recloser or relay further upstream will time out with a determined coordination time delay (typically 150-250 ms). After the timer has timed out and a permission signal from the substation is available, a trip command is issued. This scheme will allow more selective fault clearing at the cost of extended fault clearing time.



In addition to the above-described changes, the existing sensitive ground overcurrent element needs to be disabled on all reclosers and substation protection relays during REFCL operation. This is required to avoid an unselective fault clearing as all relays and reclosers will measure a ground current during a ground fault. The value of ground fault current is determined by the ground capacitance of the downstream circuit and almost independent of the fault location. This is planned by using different setting groups in the existing relays and reclosers. The activation of different settings groups in the field recloser can be performed via the communication to the substation RTAC. The substation relay settings groups can be selected via relay inputs.

No additional new devices need to be installed.

### **3.4 Communication Link Between Swedish Neutral Container and Control Shelter**

As described above, at a minimum, the trip information from the protection devices inside the Swedish Neutral Container needs to be transferred to the control shelter where it is merged into the trip logic for each feeder circuit breaker.

It is planned to hardwire the trip contact of the protection devices of the GFN to the inputs of an SEL RTAC device within the GFN container. The RTAC device will communicate via a switch inside the GFN container and a redundant fiber-optic connection to the switch in the control shelter.

The SEL RTAC offers the possibility to exchange other information between the control shelter and the GFN container. For example, it is disabled to block the REFCL scheme when the system is grounded during low fire risk conditions.

Figure 3-7 presents the different communication types that can be utilized to integrate the GFN container functionality into the Descanso Substation control architecture.

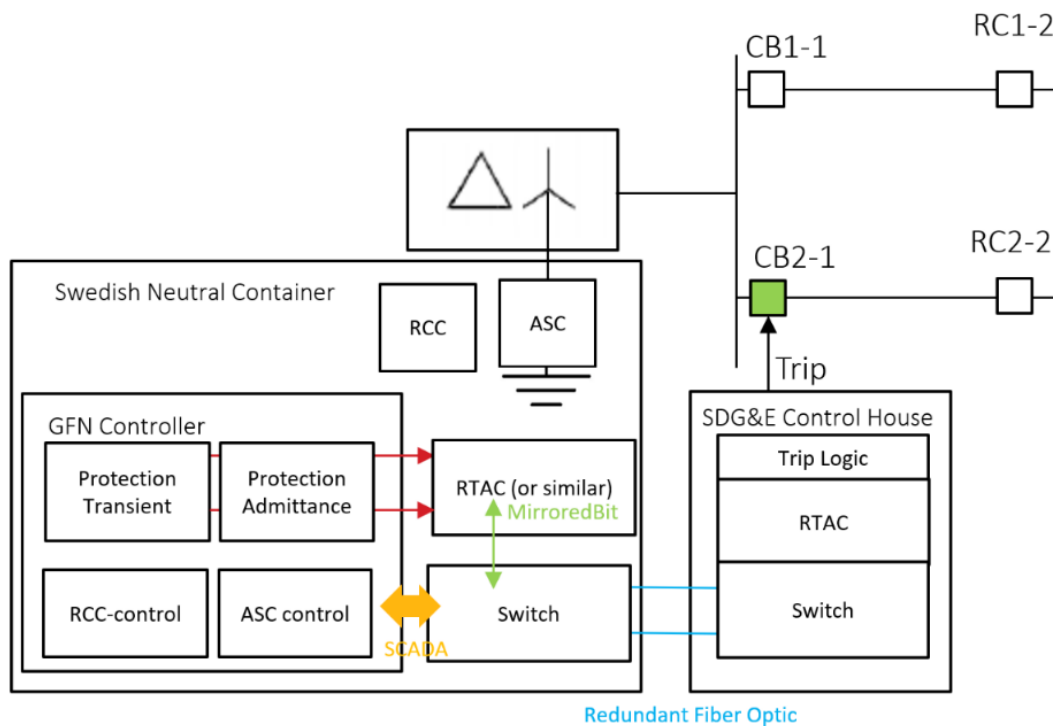


Figure 3-7. Communication Links

The fiber-optic connection between the two switches can also be utilized for SCADA communication. Swedish Neutral supports for the following protocols:

- IEC 61850
- IEC 103
- IEC 104
- Modbus
- DNP3 (via additional converter)

The SCADA link will provide monitoring and control capabilities for the GFN Controller.



## 4 12KV FEEDER CAPACITANCE BALANCING

This section discusses the capacitive balancing of Descanso Substation's distribution circuits. How the circuits are divided into sections to then be targeted for balancing is first examined. Balancing the circuits, or in part, balancing their sections, needs calculations of capacitance for each span, whether overhead or underground. The methodology of such calculation, use of the Synergi software, and verification of results are discussed as well. This knowledge would then be used to investigate how the balancing of each section of all circuits can be achieved using three alternative approaches. The result of the capacitive balancing of the circuits considers minimizing the capacitive unbalance at the substation and is presented in three solution packages. Cost estimates of capacitive balancing are discussed based on the presented solutions. Other considerations such as the importance of phase identification on the circuits are also presented. As part of this balancing effort, field measurements will be required to confirm that the required balancing has been achieved. Presently, at other utilities contacted, this measurement has only been performed at the substation rather than on feeder sections.

### 4.1 Importance of Capacitance Balancing

Fault detection during REFCL operation is based upon sensing zero-sequence voltage  $V_0$  in the substation. For the reliable performance of the REFCL fault detection, capacitive unbalance at normal (no-fault) conditions need to be as close to zero as possible, otherwise, there will be a standing residual zero-sequence voltage present at all times which will drive down the sensitivity of the system to detect faults when they occur. Balancing the phase to ground capacitance in each section of a circuit helps to reduce the asymmetry of the system and reduces the zero-sequence voltage  $V_0$  during normal operations.

The following notes are highlighted in performing the capacitance balancing of the Descanso Substation circuits:

- Capacitance balancing is performed on each section of the substation and its circuits and will be discussed in the next section; however, the final goal is to maintain the unbalance between phase to ground capacitance values as seen by the substation within the desired limit.
- Sections are defined as parts of the circuits between the circuit breaker and reclosers, between reclosers, or downstream of the farthest recloser. This selection is chosen so that balancing the sections allows for reliable operation of REFCL at the substation in no-fault conditions while reclosers are used to isolate parts of the Descanso circuits.
- Capacitance balancing is needed in any possible circuit configuration at the Descanso Substation. Different configurations will be discussed in the following text, but in brief, are achieved based on the operation of reclosers while isolating the faulted sections downstream of their location. Given any combination of operation of reclosers, the criterion of capacitance balancing as seen by the substation should hold.
- Tie switches between circuits 73 and 79 can be used to pick up the load from one to another.
- Tie switches between circuits on the Descanso Substation and circuits from other remote substations can be used to pick up the sections from the Descanso Substation. However, no section from adjacent



circuits fed by other remote substations could be picked up by the Descanso Substation and its circuits to maintain capacitance balancing within the requirements. In the latter case, the REFCL scheme at Descanso substation would need to be disabled prior to transferring other circuits from remote substations to its own circuits.

## 4.2 Feeder Sections to be Balanced

As mentioned earlier, the circuits can be partitioned in sections between reclosers and/or circuit breakers, and the capacitance balancing should be performed so any possible configuration (topology) of these circuits yields a balance capacitance seen at the substation.

As seen in Figure 4-1, the three circuits C73, C78, and C79 can be seen branching out from the center of the substation. The circular symbols on the branches represent reclosers on each of the feeders. These reclosers (a total of 15) separate the feeders and hence the substation into sections which are then considered for capacitance balancing. The 3-phase spans are shown in green and the 2-phase laterals can be seen branching out from the 3-phase lines with respective colors as shown in the picture's legend.

It is noted that Circuit 78 has single-phase underground sections with phase to neutral connected transformers. As a requirement for REFCL application, these runs need to be converted to phase to phase. Hence, prior to studying the circuits and presenting the requirements for capacitive balancing in the following sections, it is assumed that such transformation is made, i.e. the grounding bank on C78 is removed, the single phase cable is replaced with two phase cable, and phase to neutral transformers are changed with phase to phase transformers.



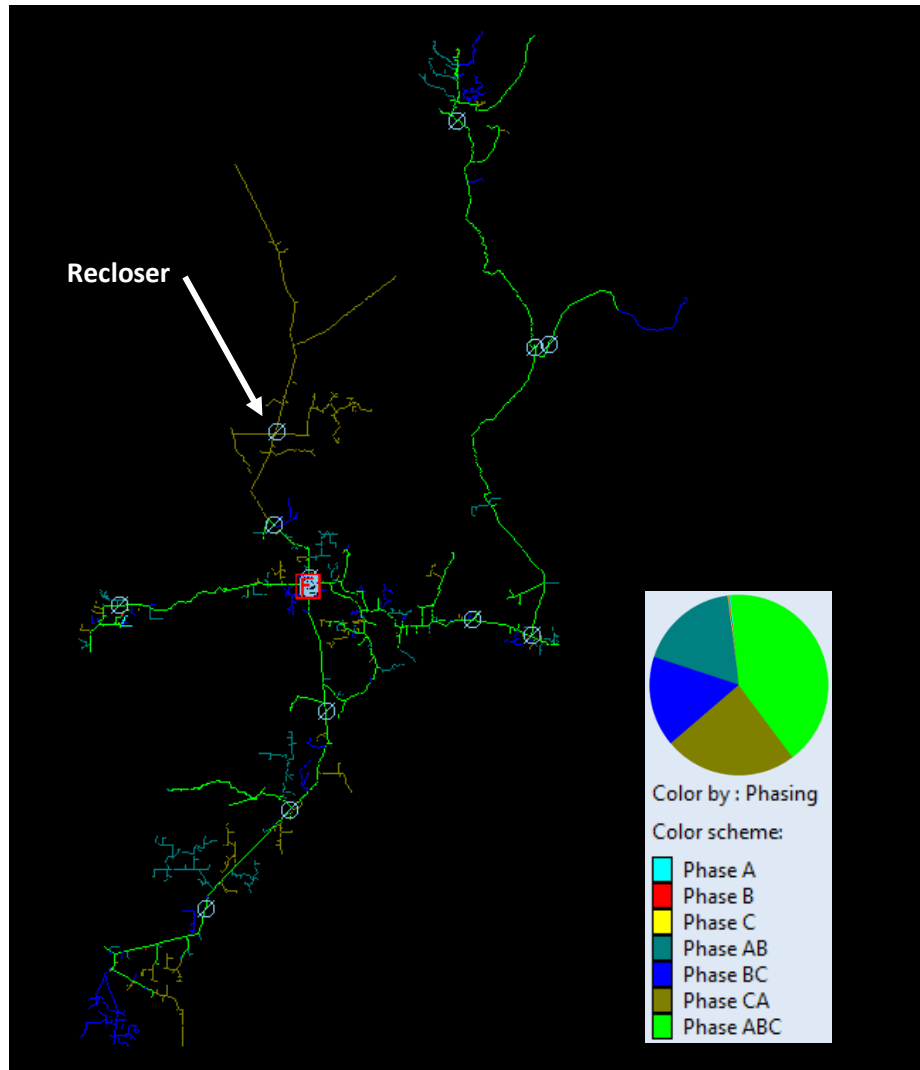


Figure 4-1. Synergi Model for Descanso Substation Displaying Circuits 73, 78 and 79

The single-line diagram for C73, C78, and C79 with their sections are shown in Figure 4-2 through Figure 4-4, respectively. The breaker along with the reclosers are shown, and coloring is also mentioned in each picture. As seen in these figures, C73 has a total of 4 sections, C78 has 2 sections, and C79 has a total of 10 sections.

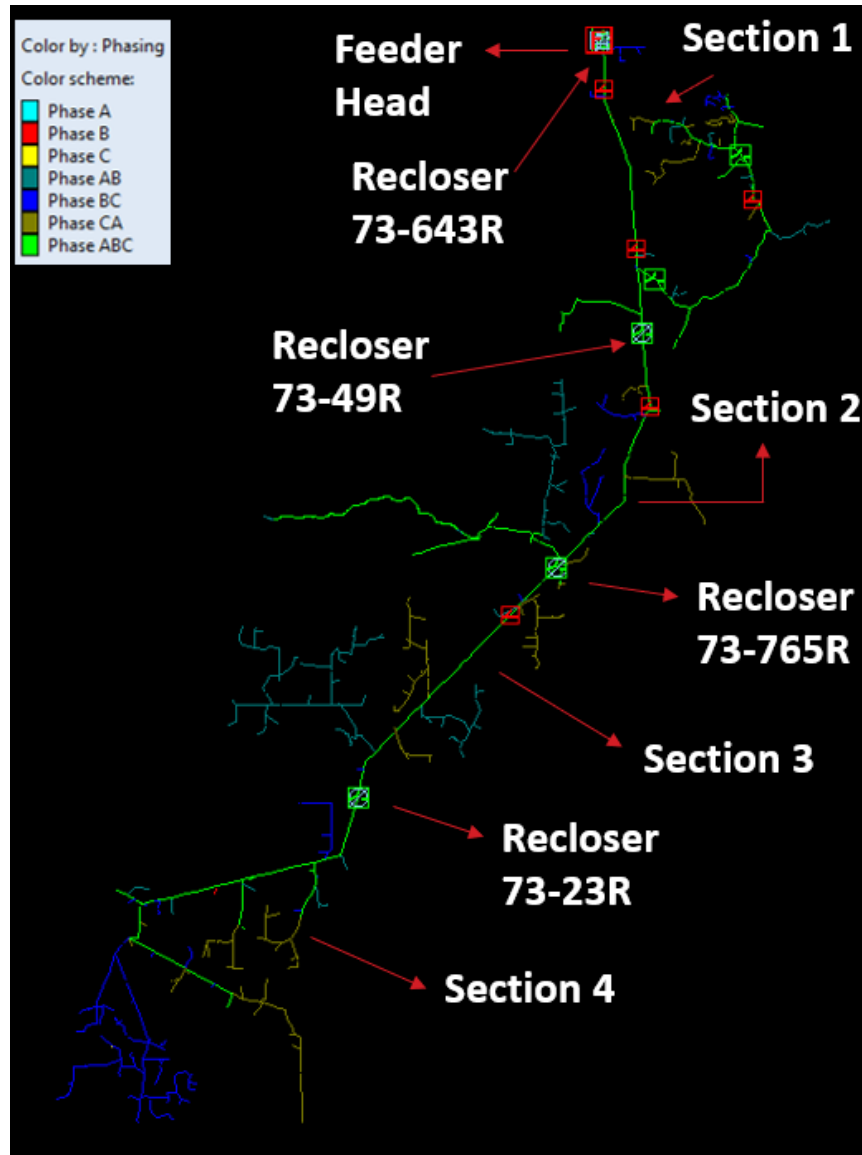


Figure 4-2. Synergi Model of Circuit 73: Individual Sections and Reclosers are Labeled Separately

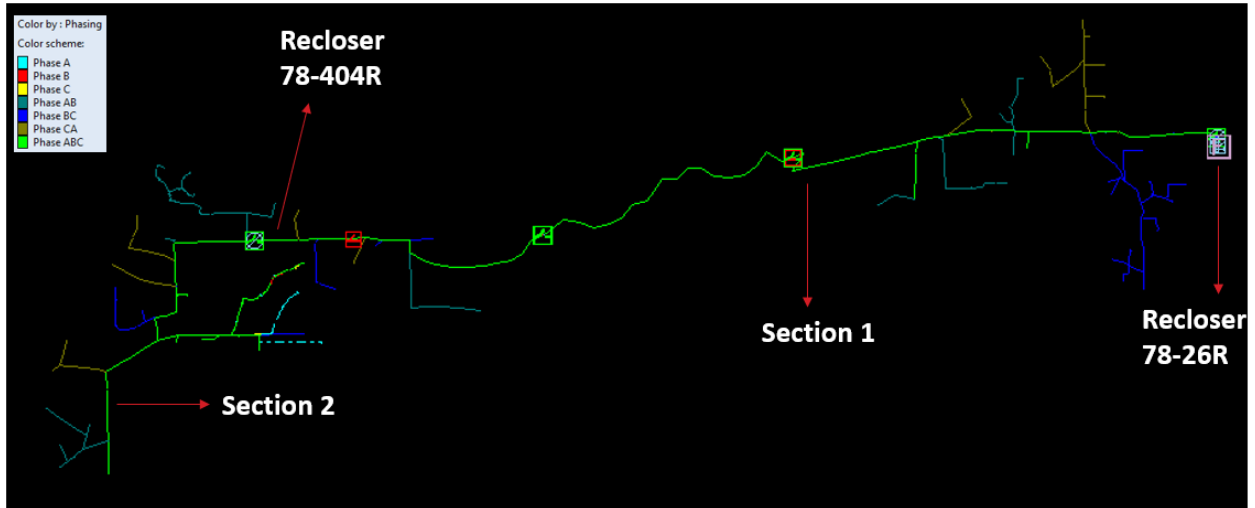


Figure 4-3. Synergi Model of Circuit 78: Individual Sections and Reclosers are Shown

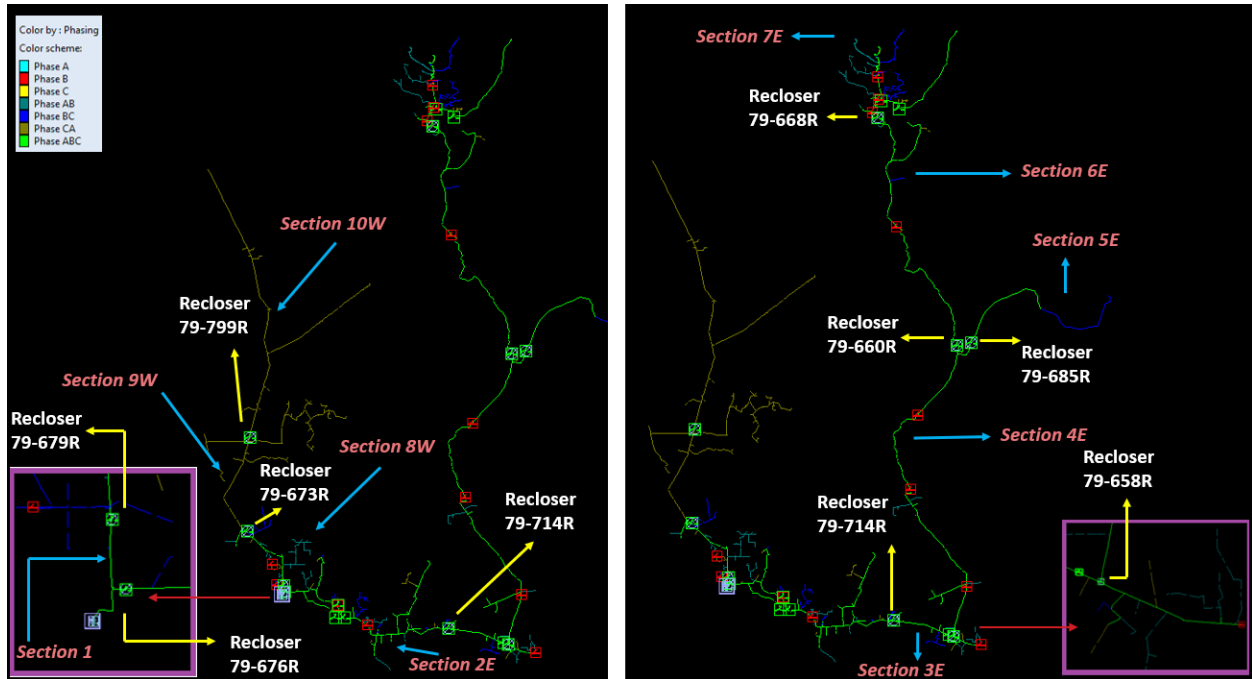


Figure 4-4. Synergi Model of Circuit 79: Sections along with Reclosers are Shown Separately



### 4.3 Synergi Methodology for Capacitance Balancing Analysis

#### 4.3.1 Using Synergi

In Synergi, the admittance and impedance values per mile of each span can be obtained for Overhead and Underground lines of each conductor type. The model has different conductor types and the circuit may have several two-phase laterals coming out and these have their impact on the total capacitance of the circuit. Clicking on “Performance tab-> Line Construction” in Synergi gives the admittance and impedance values per mile for each of the conductors in the model. The admittance values are displayed in micro Siemens ( $\mu\text{S}$ ), as shown in Figure 4-5.

Construction Summary										
Const #	Sect Cnt	Total MI	Config Id	Height Ft	Conductor Id				Z - Impedance Ohms / MI	
					A	B	C	N	Y - Admittance $\mu\text{S}$ / MI	
1	2	0	Eq. Spc. PP=0.2Ft PN=0.1Ft Multi-grnd neut	-4.0	#2 PECN PID CU		#2 PECN PID CU		***** Z *****  (1.734 +j 0.898), (0.657 +j 0.644), (0.657 +j 0.644)   (0.657 +j 0.644), (1.734 +j 0.898), (0.657 +j 0.644)   (0.657 +j 0.644), (0.657 +j 0.644), (1.734 +j 0.898)  ZO = (3.047 +j 2.186) Z1 = (1.077 +j 0.253)  ***** Y *****  (0.000 +j 101.112), (0.000 +j 0.000), (0.000 +j 0.000)   (0.000 +j 0.000), (0.000 +j 101.112), (0.000 +j 0.000)   (0.000 +j 0.000), (0.000 +j 0.000), (0.000 +j 101.112)  YO = (-0.000 +j 101.112) Y1 = (-0.000 +j 101.112)	
2	95	6	Eq. Spc. PP=0.2Ft PN=0.1Ft Multi-grnd neut	-4.0	#2 XLPECN-PEJ AL (2 ph)		#2 XLPECN-PEJ AL (2 ph)		***** Z *****  (2.447 +j 0.966), (0.683 +j 0.802), (0.683 +j 0.802)   (0.683 +j 0.802), (2.447 +j 0.966), (0.683 +j 0.802)   (0.683 +j 0.802), (0.683 +j 0.802), (2.447 +j 0.966)  ZO = (3.812 +j 2.571) Z1 = (1.764 +j 0.164)  ***** Y *****  (0.000 +j 101.112), (0.000 +j 0.000), (0.000 +j 0.000)   (0.000 +j 0.000), (0.000 +j 101.112), (0.000 +j 0.000)   (0.000 +j 0.000), (0.000 +j 0.000), (0.000 +j 101.112)  YO = (-0.000 +j 101.112) Y1 = (-0.000 +j 101.112)	

Figure 4-5. Values of Y and Z Matrices of Individual Conductors in the Synergi Model of Descanso Substation

The above matrix is of the form:

$$[Y_{Gnd}] = \begin{bmatrix} Y_{AG} + Y_{AB} + Y_{AC} & -Y_{AB} & -Y_{AC} \\ & Y_{BG} + Y_{AB} + Y_{BC} & -Y_{BC} \\ & & Y_{CG} + Y_{AC} + Y_{BC} \end{bmatrix}$$

[Eq. 4-1]

These equations can be found in any reference textbooks related to Power Systems, such as [1]. Thus, we can obtain the  $Y_{AG}$  value by summing the first-row elements of the Y matrix above, and then calculate the  $C_{AG}$  value as:

$$C_{AG} = \frac{Y_{AG}}{120 * \pi} \quad \text{[Eq. 4-2]}$$



Thus, the Capacitance to ground values  $C_{AG}$ ,  $C_{BG}$ ,  $C_{CG}$ , and phase-phase capacitances  $C_{AB}$ ,  $C_{BC}$ , and  $C_{AC}$  can be obtained anytime from the above equations.

### 4.3.2 Confirming Synergi Results

To further understand and study the results obtained from Synergi, calculating the Y matrix was also performed in MATLAB. Equations provided by [1] were used to calculate the line parameters while the pole geometry and line conductor data in Synergi were chosen as the input. A 10-mile long overhead line was modeled with no load in Synergi. This was decided to properly reflect the zero-load current flowing in the line, and that the flow would be only due to the line-charging capacitance of the conductors. Both phase and neutral conductors were modeled using the 336.4 ACSR conductor. The Y and Z matrices can now be achieved as mentioned before (shown previously in Figure 4-5).

To verify these Y and Z matrices, a MATLAB code was written, which calculates the corresponding matrices and determines the kVar flow values at the circuit head. The values obtained were cross-checked with Synergi for the 10-mile line. The code accepts certain input parameters and performs the calculations. The input parameters are diameters of phase and neutral conductors, the resistance of conductors in ohms/mile, length, nominal voltage, actual voltage, kV rated voltage, distance between phase-phase conductors, distance between phase and neutral conductors, and the height of the cross arms. The Kron reduction technique utilized in [1] is applied here to determine the capacitance values and the Y matrix.

The results obtained from the Synergi and MATLAB code are shown in Figure 4-6.

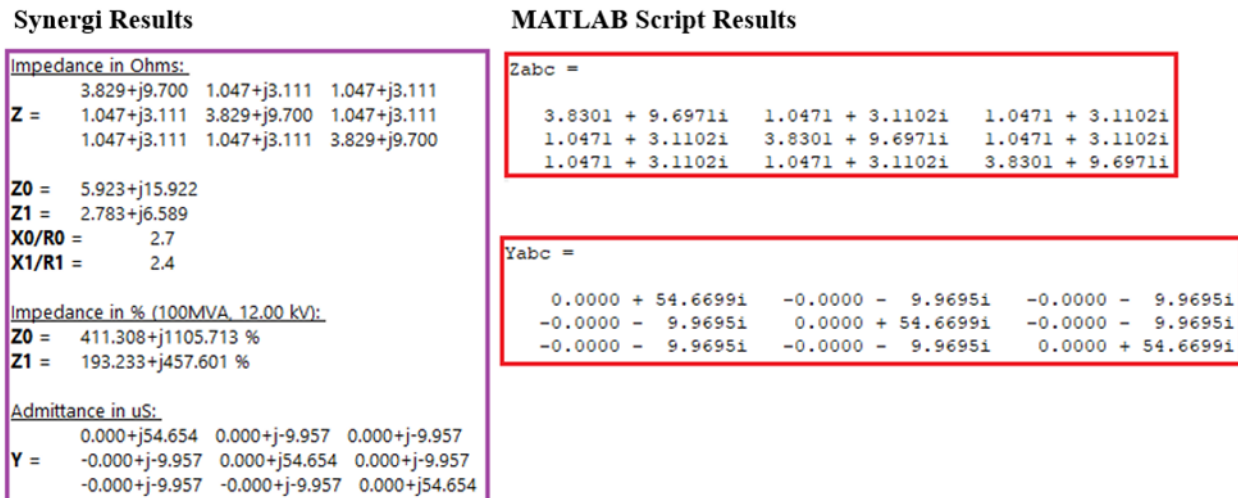


Figure 4-6. Comparison of Y and Z Matrices Obtained from Synergi and MATLAB Code

### 4.3.3 Calculating the Capacitances from Synergi Exported Values

For the Descanso Substation, the Y matrix data for each conductor type which exists in the substation was exported into an Excel sheet. The capacitance values between each phase and the ground per mile, namely,  $C_{AG}$ ,  $C_{BG}$ ,  $C_{CG}$ , as well as phase-to-phase capacitances per mile  $C_{AB}$ ,  $C_{BC}$ , and  $C_{AC}$  were calculated for



each of the conductors present in the substation and its circuits. The list of conductors in the substation was obtained through the Load Flow tab through Facilities-> Conductor.

Since the capacitance values of each conductor type are obtained per length, the total capacitance values in the model can be calculated considering the available length of each conductor type and their phasing. For example, the capacitance between phase A to ground for a specific conductor is calculated by multiplying  $C_{AG}$  per mile for that conductor with the summation of the lengths of ABCN, ABN, CAN, and AN phasing of that conductor.

Therefore, the total capacitance to ground  $C_{AG}$ ,  $C_{BG}$ , and  $C_{CG}$  for each Synergi model can be determined using the same approach. Below is an image showing the capacitance-to-ground values calculated by applying the above procedure for the Descanso Substation.

Table 4-1 presents the capacitance-to-ground values calculated for each of the conductors present in Descanso Substation.

**Table 4-1. Capacitance-to-Ground Values Calculated for Each of the Conductors Present in Descanso Substation**

Conductor	ABC (mi)	AB (mi)	AC (mi)	BC (mi)	AG $\mu$ F	BG $\mu$ F	CG $\mu$ F
636 ACSR	2.473	0.000	0.000	1.162	0.024	0.035	0.035
336.4 ACSR	3.790	0.000	0.000	0.000	0.035	0.035	0.035
3/0 ACSR	0.289	0.000	0.000	0.000	0.003	0.003	0.003
1/0 AWAC (4/3)	4.470	0.000	0.000	0.000	0.038	0.038	0.038
1/0 B.STRD CU	16.515	0.000	0.000	0.000	0.139	0.139	0.139
#1 B.STRD CU	0.088	0.000	0.000	0.000	0.001	0.001	0.001
#2 5005 AL	0.113	0.216	0.111	0.379	0.004	0.006	0.005
#2 B.STRD CU	0.017	0.000	0.460	0.000	0.004	0.000	0.004
#2 AWAC (5/2)	13.551	10.239	9.175	6.941	0.273	0.254	0.246
#2 ACSR	1.314	10.197	12.175	10.634	0.195	0.183	0.199
#2 AWAC (3/4)	0.409	0.131	8.321	0.000	0.075	0.005	0.074
#4 B.STRD CU	7.392	0.270	0.941	0.345	0.069	0.064	0.070
#4 A CUWLD	0.974	0.000	1.970	0.029	0.024	0.008	0.024
#6A CUWELD	3.234	0.285	1.066	0.572	0.036	0.032	0.039
#6 B.STRD CU	1.146	2.274	0.319	0.740	0.029	0.032	0.017
2/0 XLPECN-PEJ AL	2.848	0.000	0.000	0.000	1.027	1.027	1.027
#2 PECN-PEJ AL	0.000	0.191	0.327	0.432	0.139	0.167	0.203
#2 SOL TRXLPECN-PEJ AL PID	0.000	0.028	0.000	0.057	0.008	0.023	0.015
#2 PECN PID CU	0.000	0.000	0.034	0.000	0.009	0.000	0.009



Conductor	ABC (mi)	AB (mi)	AC (mi)	BC (mi)	AG $\mu$ F	BG $\mu$ F	CG $\mu$ F
#2 PECN PID AL	0.000	0.064	0.081	0.051	0.039	0.031	0.035
#2 PECN CU	0.000	0.000	0.099	0.000	0.027	0.000	0.027
#2 XLPECN-PEJ AL (1 ph)	0.000	0.069	0.486	0.104	0.149	0.047	0.158
#2 XLPECN-PEJ AL (2 ph)	0.000	2.671	0.550	2.712	0.864	1.444	0.875
#2 XLPECN-PEJ AL (3 ph)	0.931	0.000	0.000	0.000	0.251	0.251	0.251
3/0 15kV Spacer Cable AL	1.925	0.000	0.000	0.000	0.018	0.018	0.018
1/0 15kV Spacer Cable AL	0.155	0.240	0.000	0.162	0.004	0.005	0.003
Total	61.643	26.887	36.125	24.332	3.480	3.846	3.548

Following this approach, Synergi calculations, which match with the code developed to calculate the line parameters were extracted once for each conductor type into the database. Moving forward, Synergi was merely used to extract the length of each conductor type in the Synergi models created for each section of the substation and its circuits, which improved the efficiency and accuracy of the workflow.

## 4.4 Capacitance Balancing Method

### 4.4.1 Capacitance Values in the Base Case

Using the aforementioned approach, we have calculated the capacitance values per phase for each section of the three circuits. The following figures display each section of the three circuits separately along with bar graphs that show lengths of the individual phasing of conductors in the section.



Figure 4-7 through Figure 4-10 present sections 4 through 1 on circuit 73.

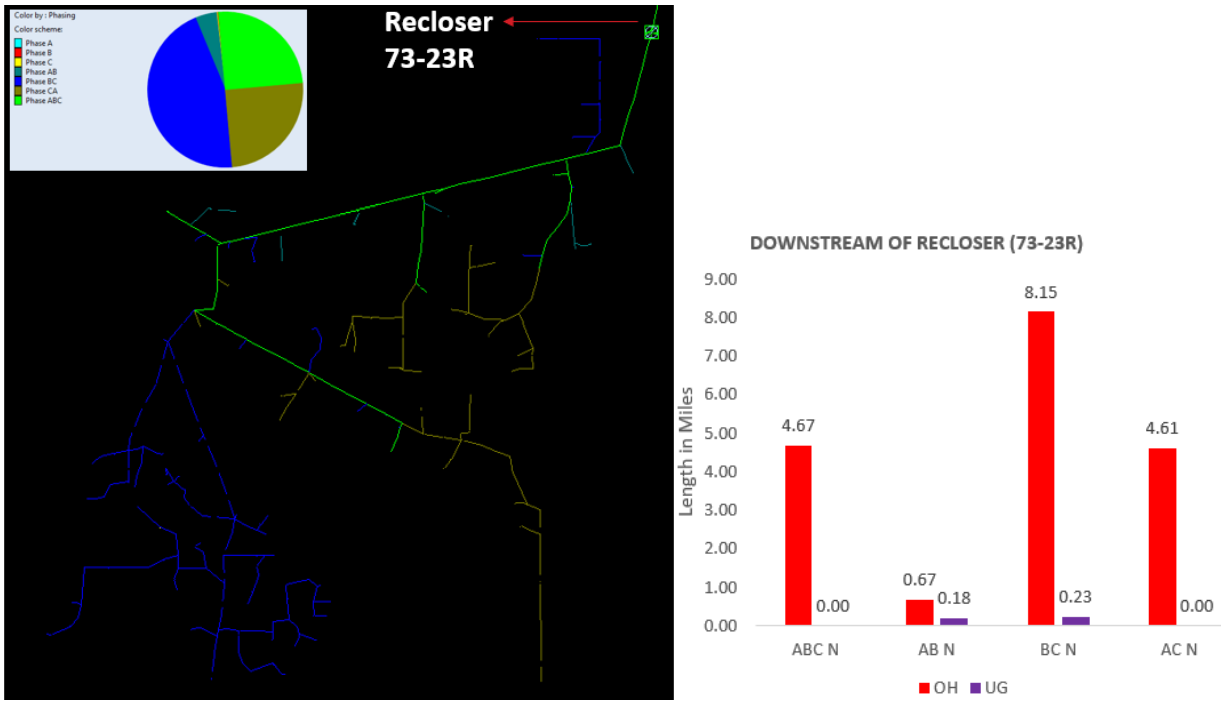


Figure 4-7. Synergi Model of Section 4 of C73 Showing Phasing of Conductors with Their Respective Length

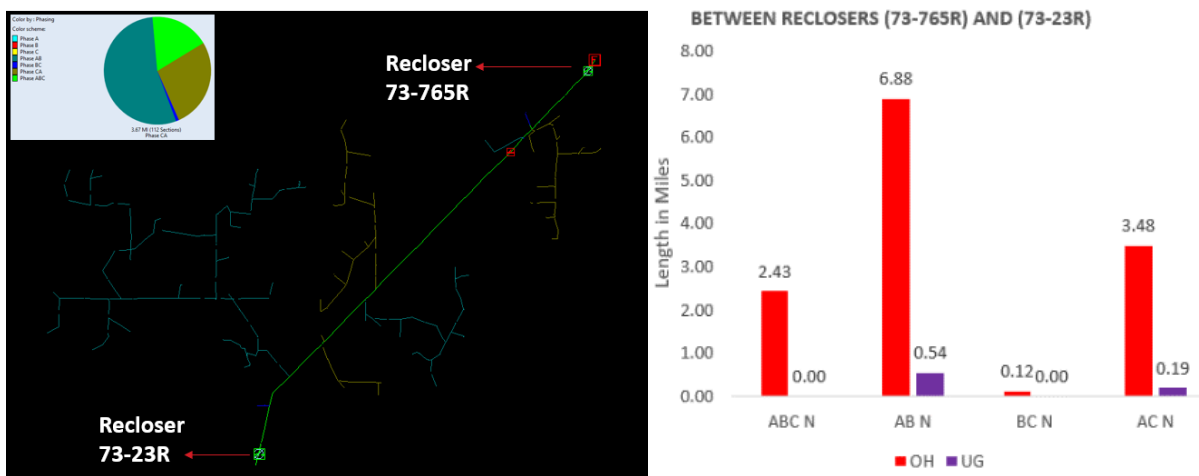


Figure 4-8. Synergi Model of Section 3 of C73 Showing Phasing of Conductors with Their Respective Length



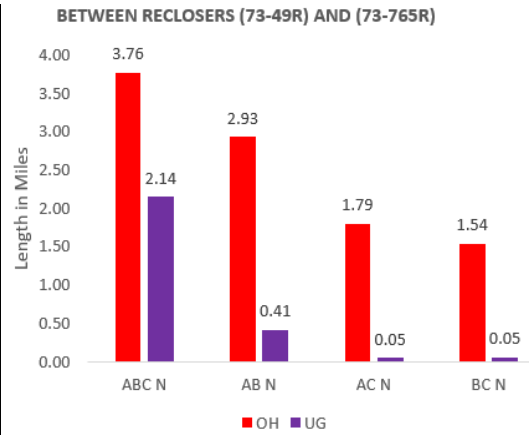
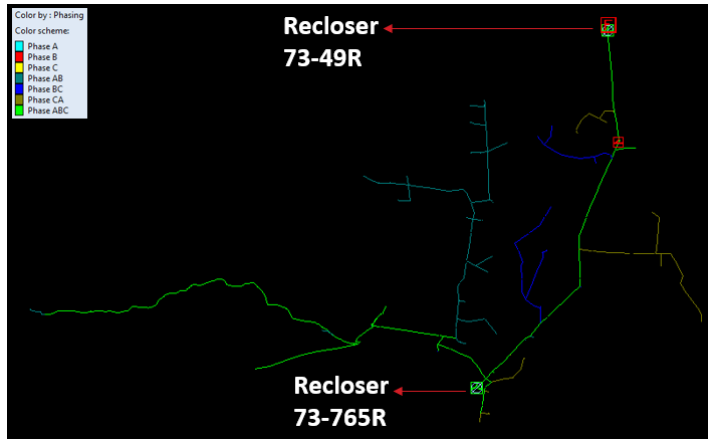


Figure 4-9. Synergi Model of Section 2 of C73 Showing Phasing of Conductors with Their Respective Length

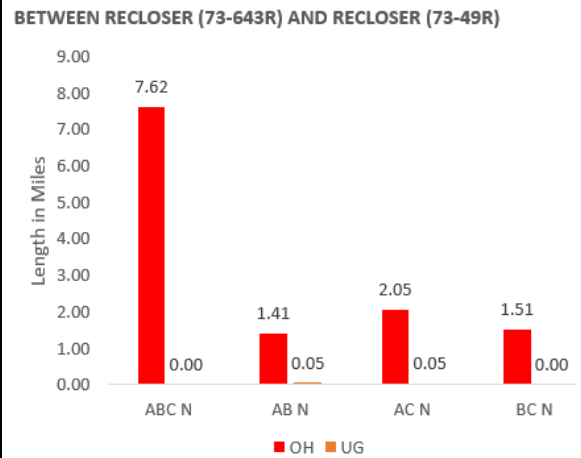
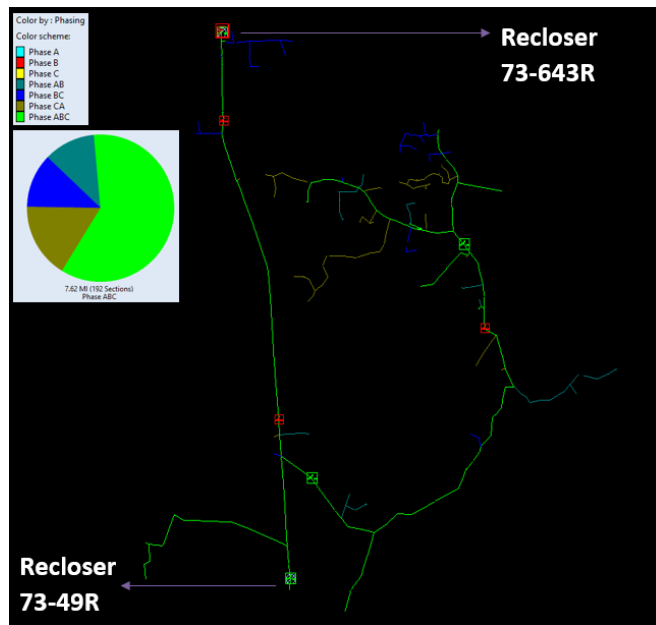


Figure 4-10. Synergi Model of Section 1 of C73 Showing Phasing of Conductors with Their Respective Length



Figure 4-11 and Figure 4-12 present sections 2 and 1 on circuit 78.

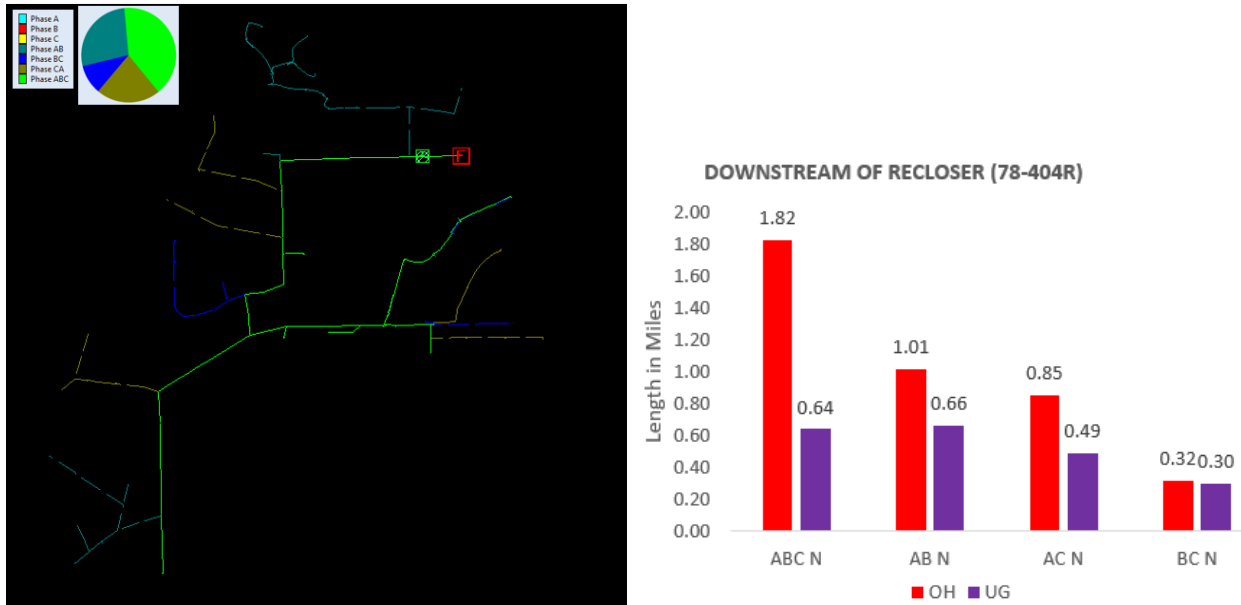


Figure 4-11. Synergi Model of Section 2 of C78 Showing Phasing of Conductors with Their Respective Length

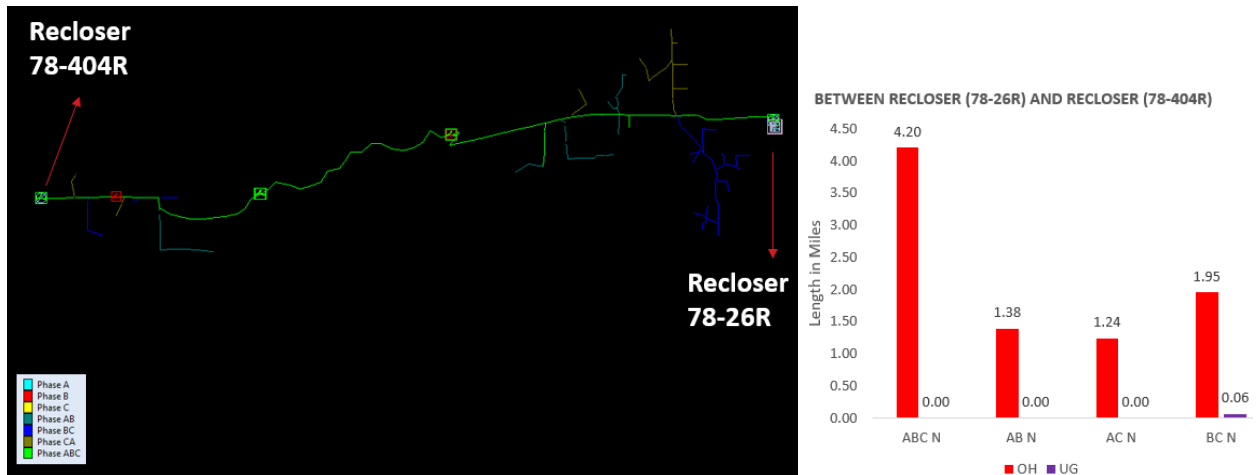


Figure 4-12. Synergi Model of Section 1 of C78 Showing Phasing of Conductors with Their Respective Length



Figure 4-13 through Figure 4-22 present multiple sections on circuit 79.

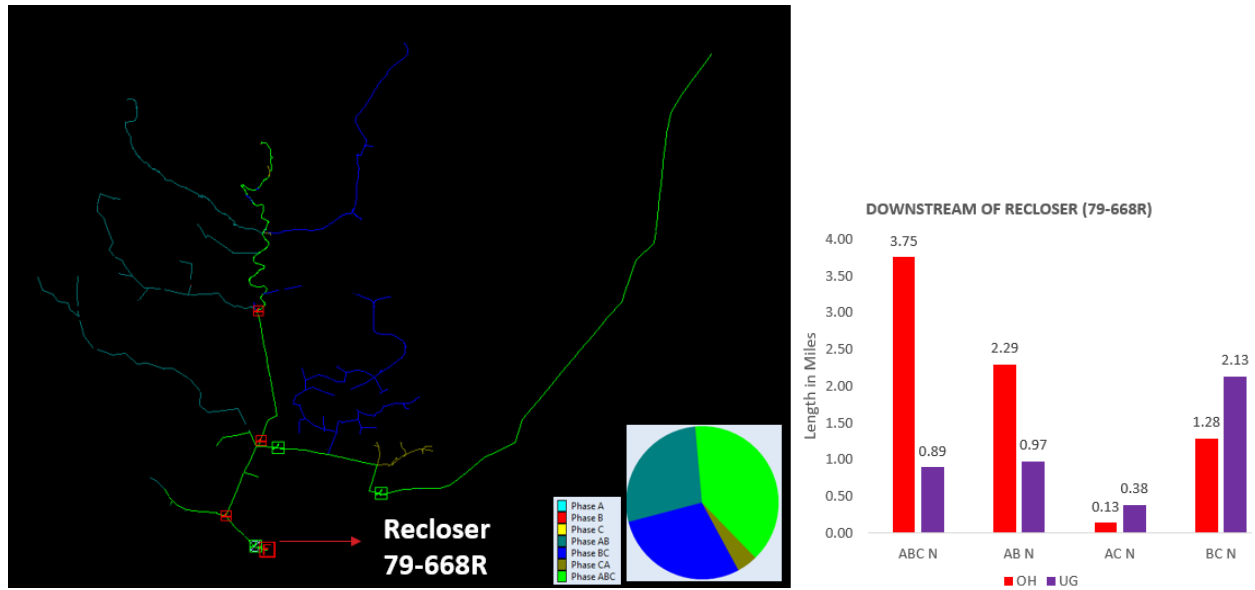


Figure 4-13. Synergi Model of Section 7E of C79 Showing Phasing of Conductors with Their Respective Length

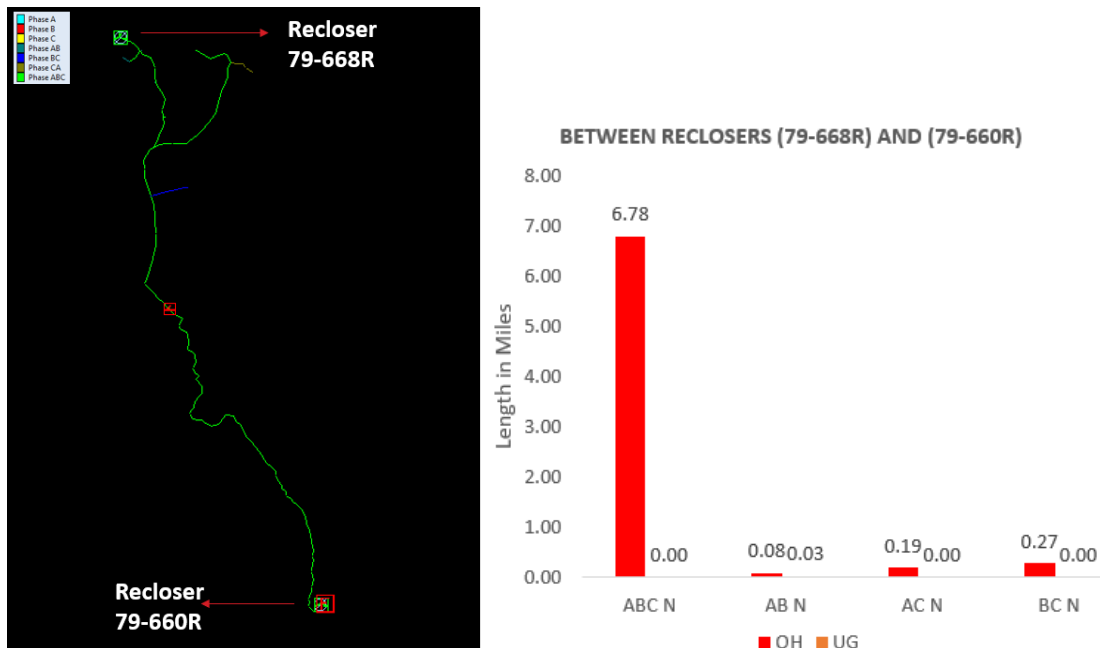


Figure 4-14. Synergi Model of Section 6E of C79 Showing Phasing of Conductors with Their Respective Length

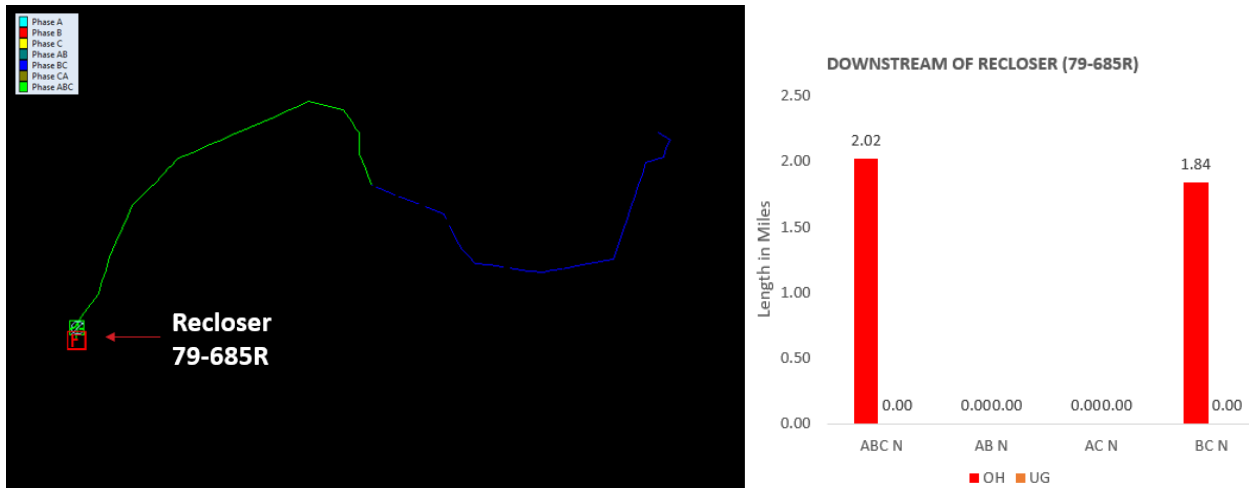


Figure 4-15. Synergi Model of Section 5E of C79 Showing Phasing of Conductors with Their Respective Length

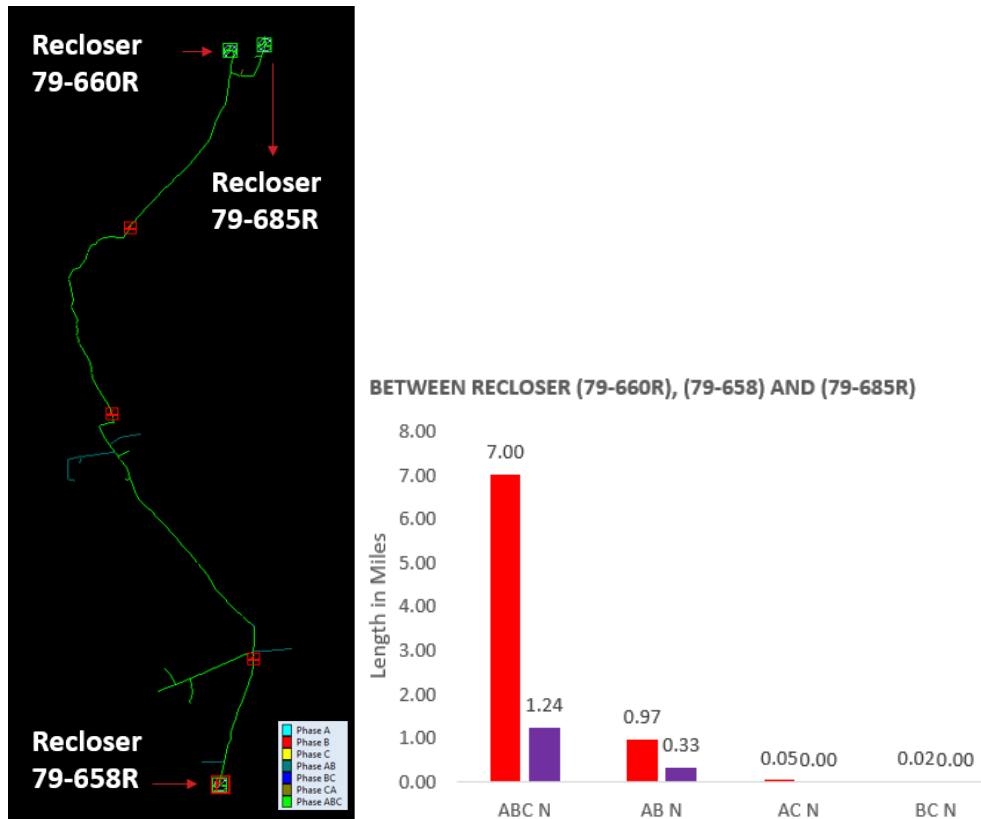


Figure 4-16. Synergi Model of Section 4E of C79 Showing Phasing of Conductors with Their Respective Length

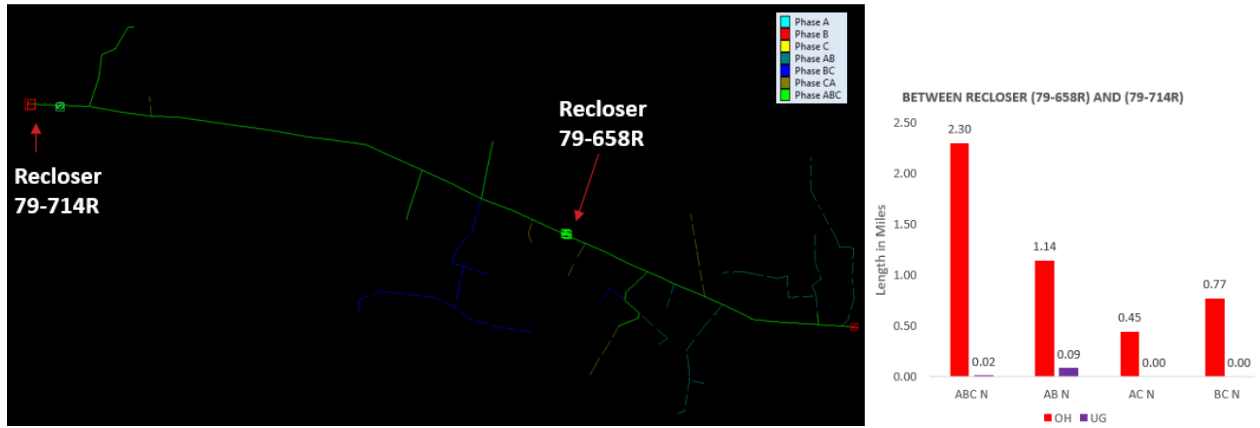


Figure 4-17. Synergi Model of Section 3E of C79 Showing Phasing of Conductors with Their Respective Length

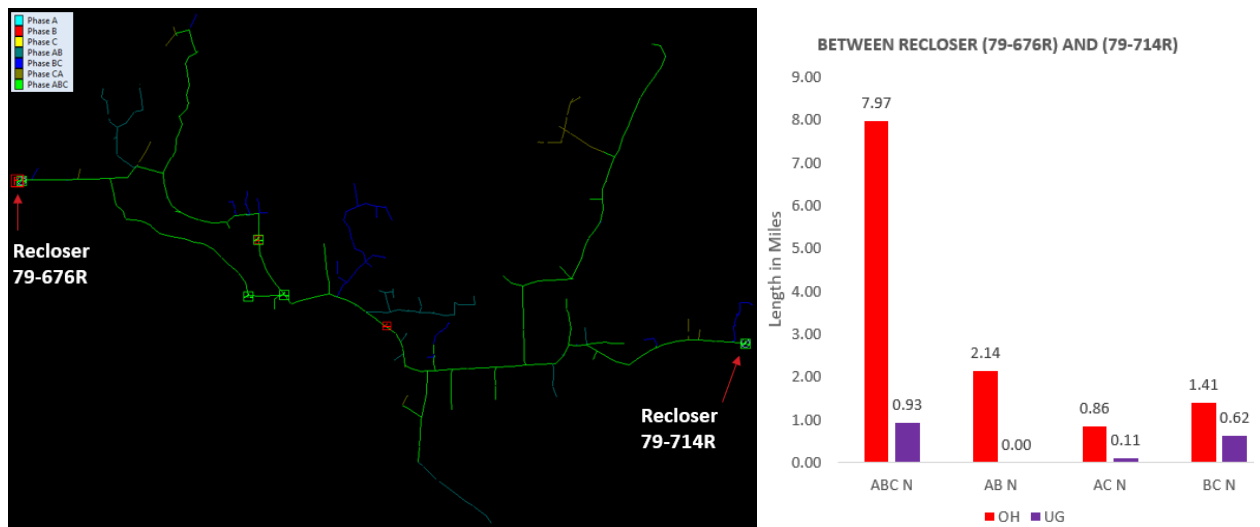


Figure 4-18. Synergi Model of Section 2E of C79 Showing Phasing of Conductors with Their Respective Length

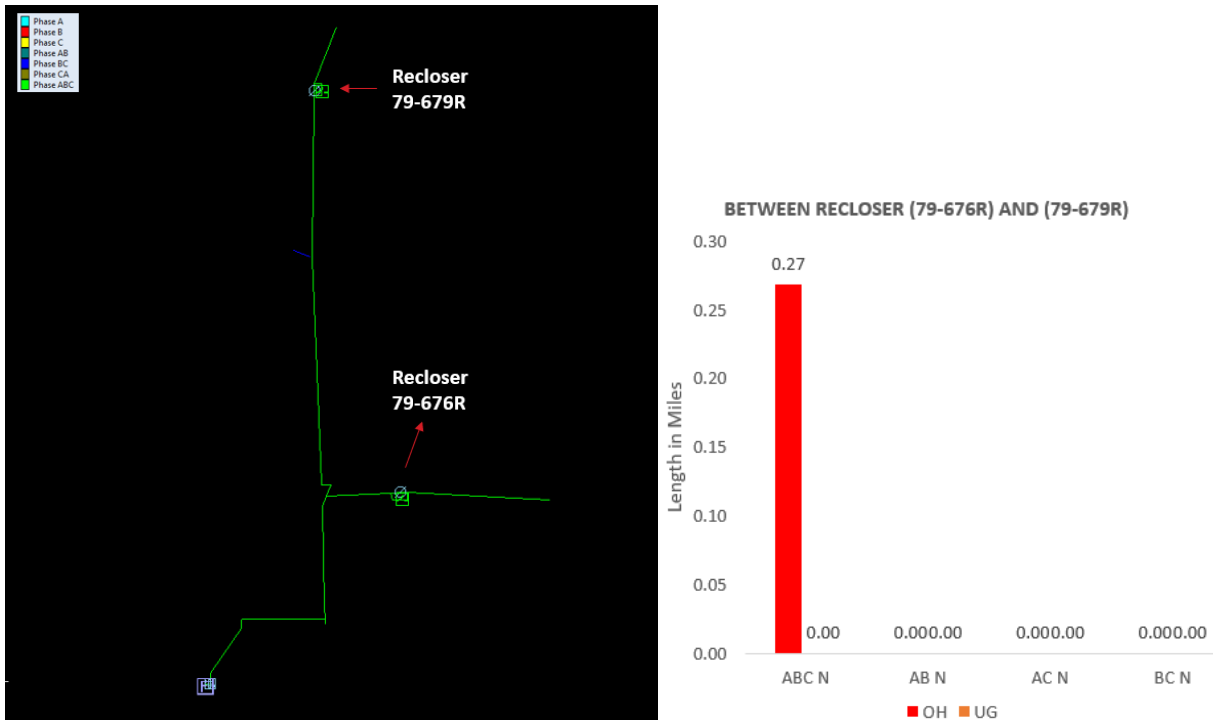


Figure 4-19. Synergi Model of Section 1 of C79 Showing Phasing of Conductors with Their Respective Length

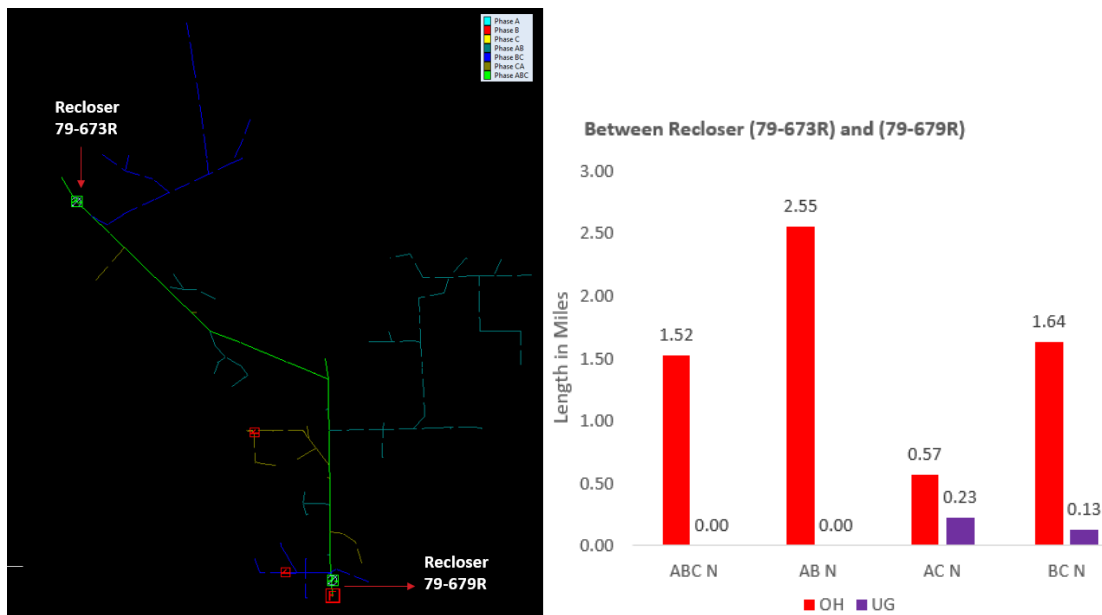


Figure 4-20. Synergi Model of Section 8W of C79 Showing Phasing of Conductors with Their Respective Length

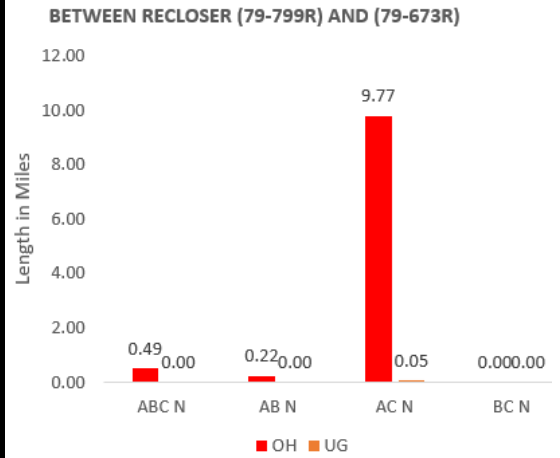
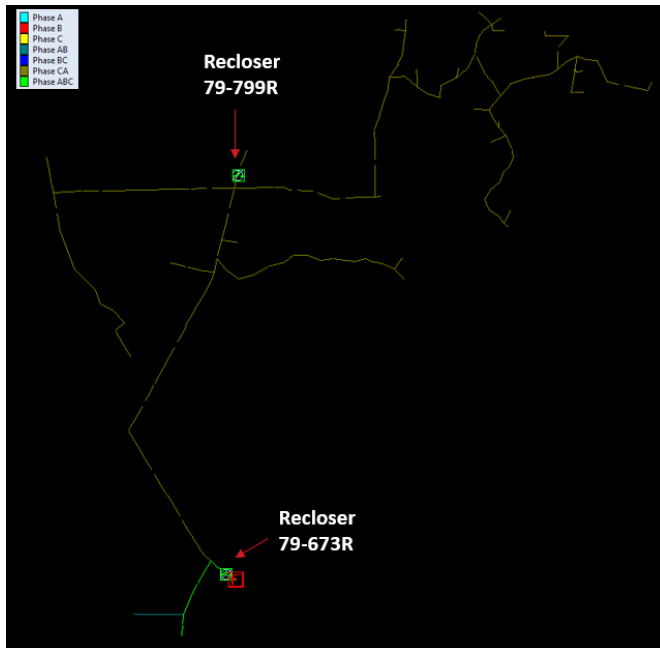


Figure 4-21. Synergi Model of Section 9W of C79 Showing Phasing of Conductors with Their Respective Length

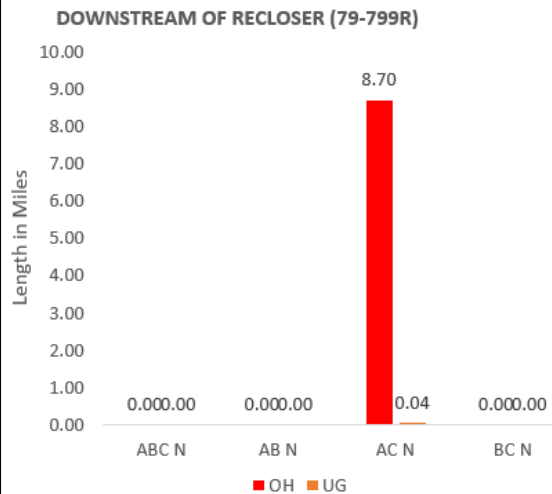
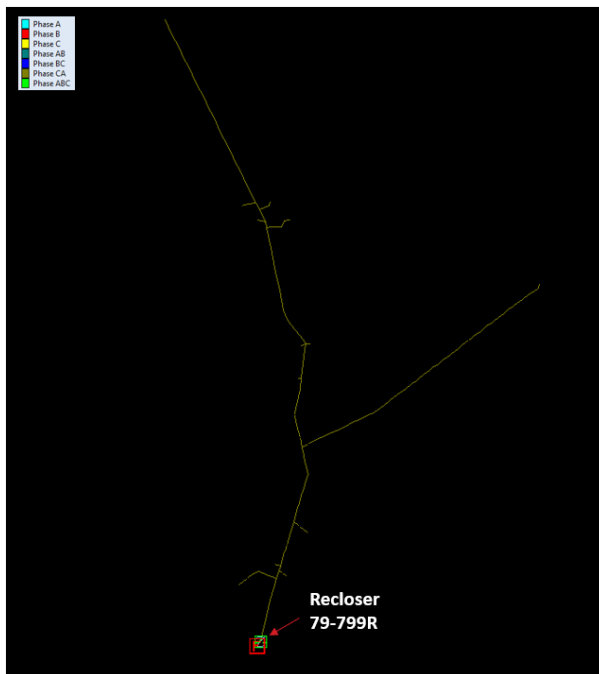


Figure 4-22. Synergi Model of Section 10W of C79 Showing Phasing of Conductors with Their Respective Length



In the base case (i.e., the current status of the circuits), the following results are achieved for capacitance values of the sections., as shown in Table 4-2. This table shows that the Base Case does not meet the capacitance balance criterion at the substation, as the magnitude of the capacitance unbalance is 963% (almost 10 times) of what is required based on the selected requirement of < 0.0348  $\mu$ F. The table also shows that some of the 16 sections show an even higher unbalance compared to other sections. Note that the unbalance seen at the substation is a vector summation of individual unbalance values of each section, and therefore some higher unbalances at individual sections are compensated by the unbalance of other sections.

**Table 4-2. Capacitance Values (in microfarads [ $\mu$ F]) for Different Sections of Descanso Substation in the Base Case**

C73	C78	C79	Substation	Phase A	Phase B	Phase C	Unbalance
Section	Section	Section	Section	$\mu$ F	$\mu$ F	$\mu$ F	% to 0.0348 $\mu$ F
4			1	0.131	0.224	0.207	245%
3			2	0.3	0.222	0.1	499%
2			3	0.949	0.948	0.84	310%
1			4	0.117	0.1	0.104	44%
	2		5	0.51	0.456	0.408	253%
	1		6	0.058	0.08	0.078	60%
		7E	7	0.735	1.189	1.013	1133%
		6E	8	0.067	0.067	0.061	17%
		5E	9	0.017	0.032	0.032	43%
		4E	10	0.133	0.133	0.094	111%
		3E	11	0.061	0.063	0.034	80%
		2E	12	0.132	0.255	0.275	383%
		1	13	0	0	0	0%
		8W	14	0.099	0.081	0.125	109%
		9W	15	0.1	0.006	0.098	266%
		10W	16	0.084	0	0.084	240%
<b>Sum (seen at the substation)</b>				<b>3.493</b>	<b>3.856</b>	<b>3.553</b>	<b>963%</b>

#### 4.4.2 Capacitance Values After Performing Phase Swaps

Two-phase laterals are derived from 3-phase spans on the circuits. Depending on the initial capacitance values between the phases and the ground, swapping the phases on laterals of the studied section can be targeted to change the capacitance values. The following comments are highlighted in Figure 4-23:





- The phase swap on an OH lateral is depicted in Figure 4-23. This suggested phase swap is targeting a change from phases AC to phases BC for the branch.
- The phase swap depicted will cause everything downstream of this pole on the branched lateral to change phases.
- Phase swaps can be wisely chosen to balance the capacitance values between the phases of each section of the Descanso Substation and its circuits. The move from phases AC to BC, as depicted in Figure 4-23, will maintain the capacitance value of phase C to the ground, reduce the capacitance value between Phase A and ground, and equally increase the capacitance value between phase B and ground.

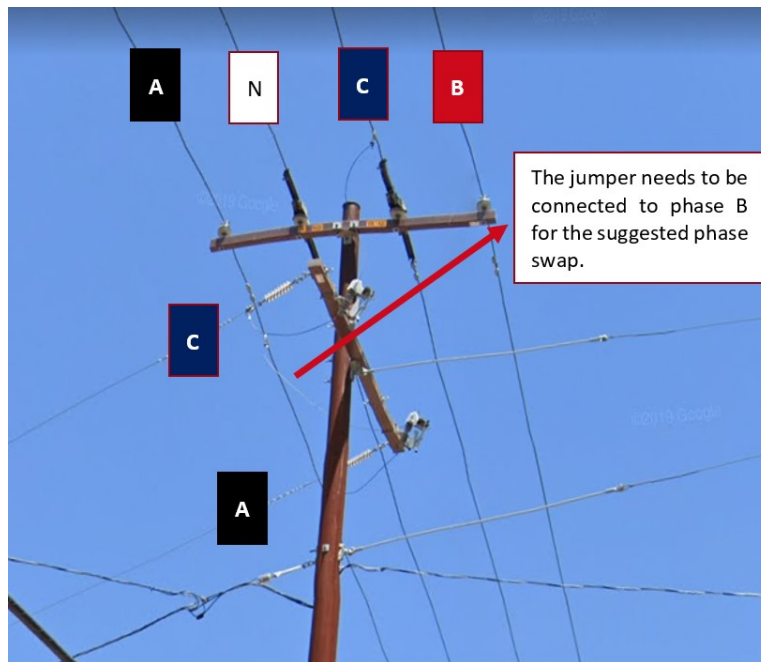


Figure 4-23 Example of Phase Swap on an OH Lateral

Circuit 73 sections are further balanced using the phase swap method for two-phase laterals as presented for each section. Phase swaps are mentioned on the Synergi model in the figures below, for instance, “BC-AC” means a phase swap changing the lateral from phases B and C, to phases A and C.



Figure 4-24 through Figure 4-27 present phase swaps on circuit 73 (sections 4 through 1).

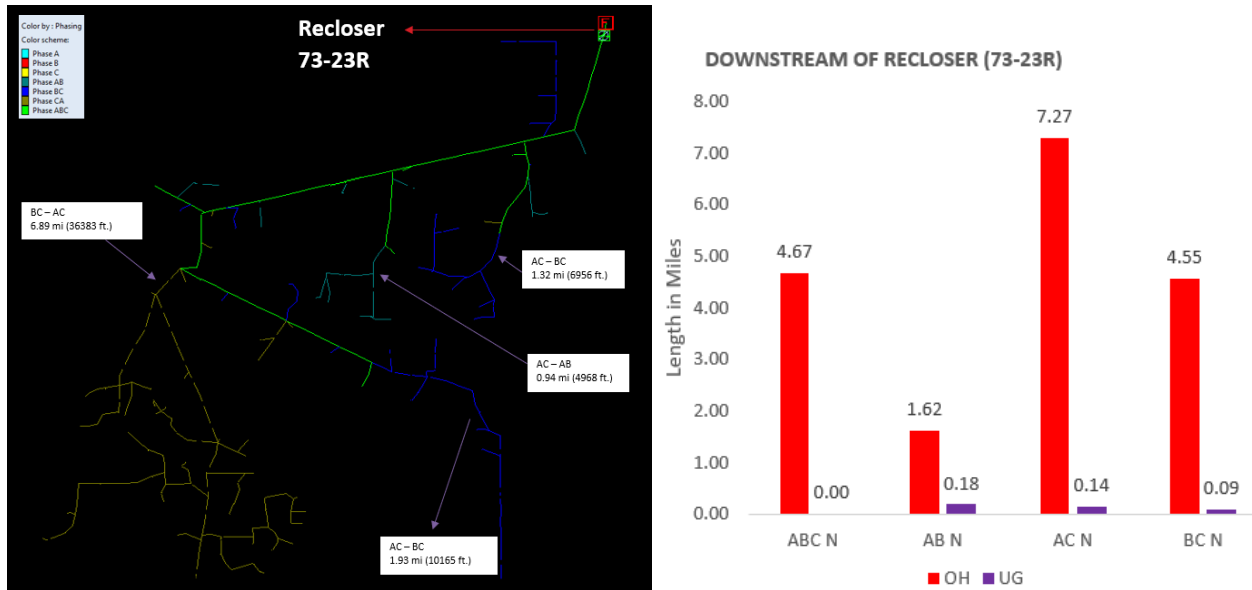


Figure 4-24. Section 4 Phase Swaps on C73

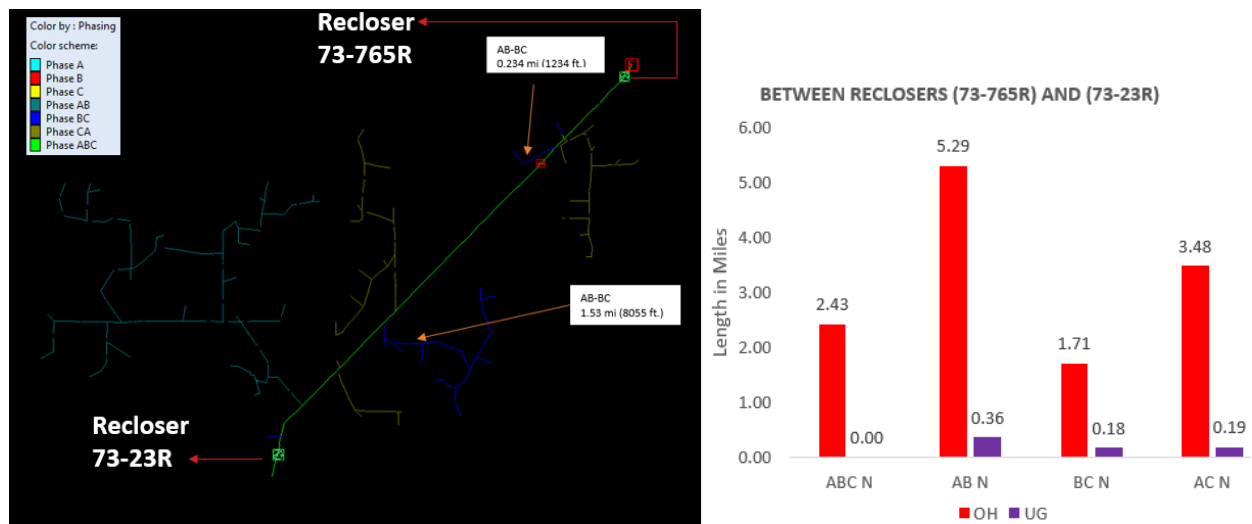


Figure 4-25. Section 3 Phase Swaps on C73

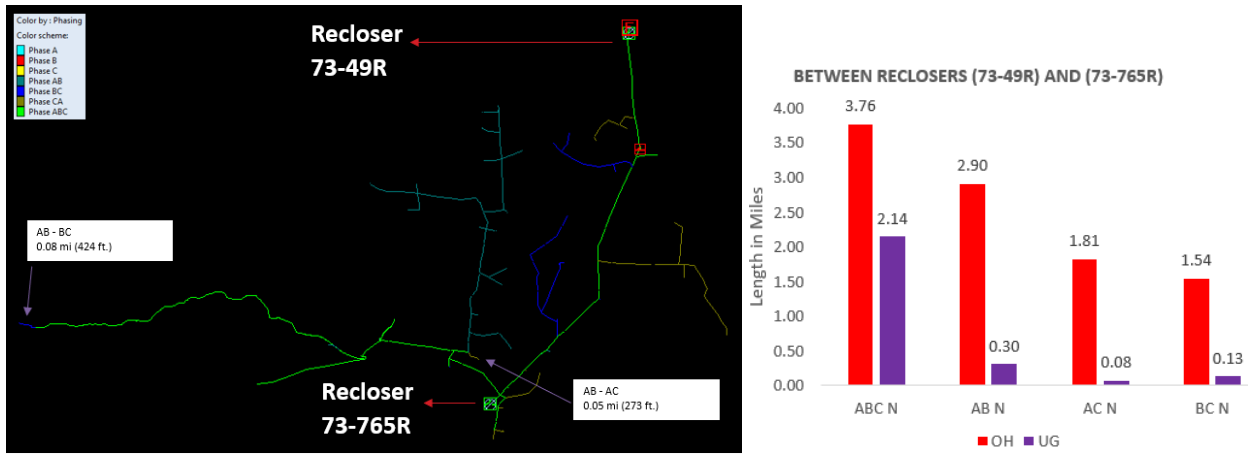


Figure 4-26. Section 2 Phase Swaps on C73

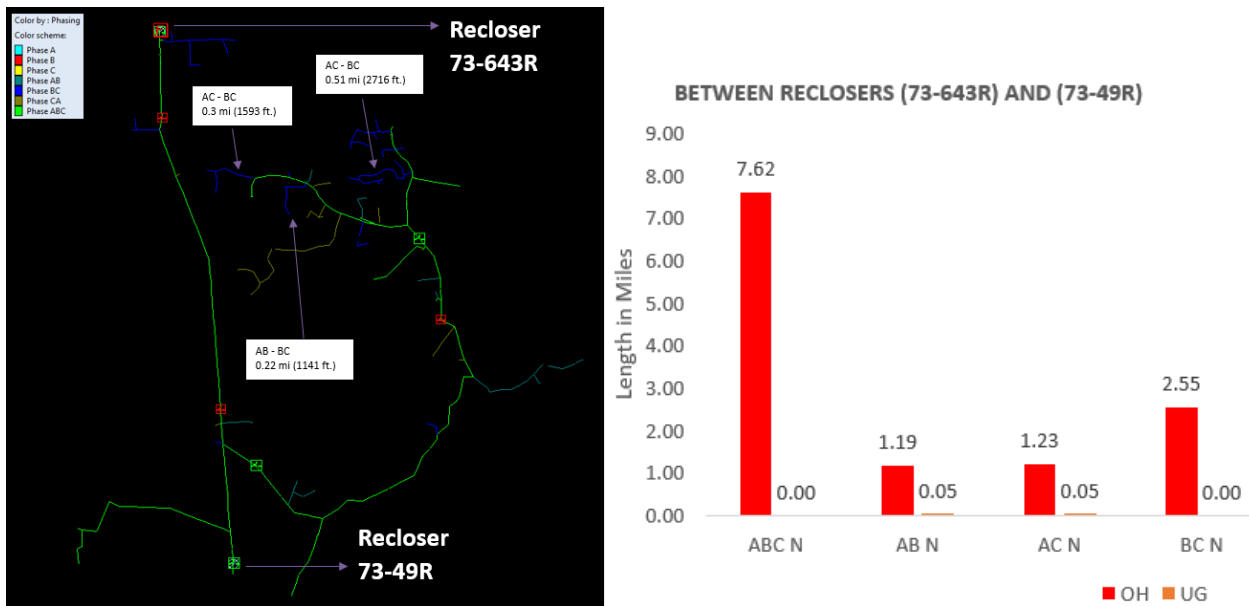


Figure 4-27. Section 1 Phase Swaps on C73



Figure 4-28 and Figure 4-29 present phase swaps on circuit 78 (sections 2 and 1).

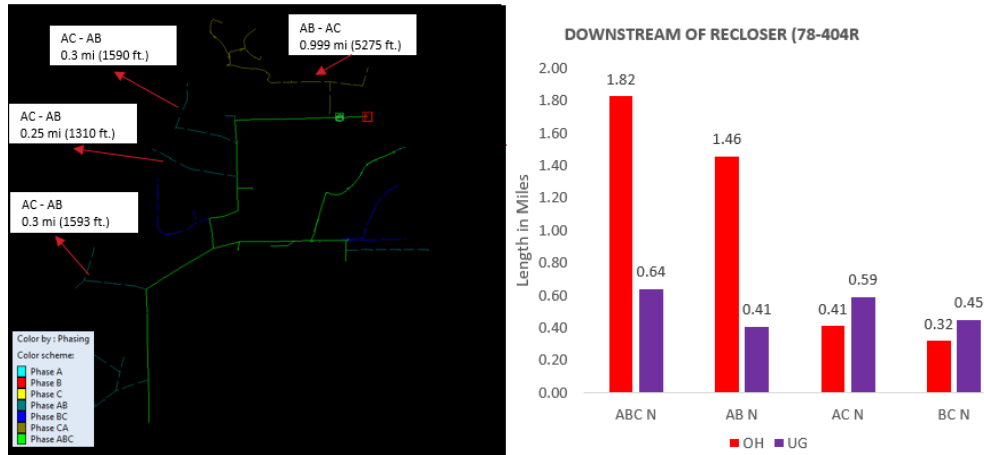


Figure 4-28. Section 2 Phase Swaps on C78

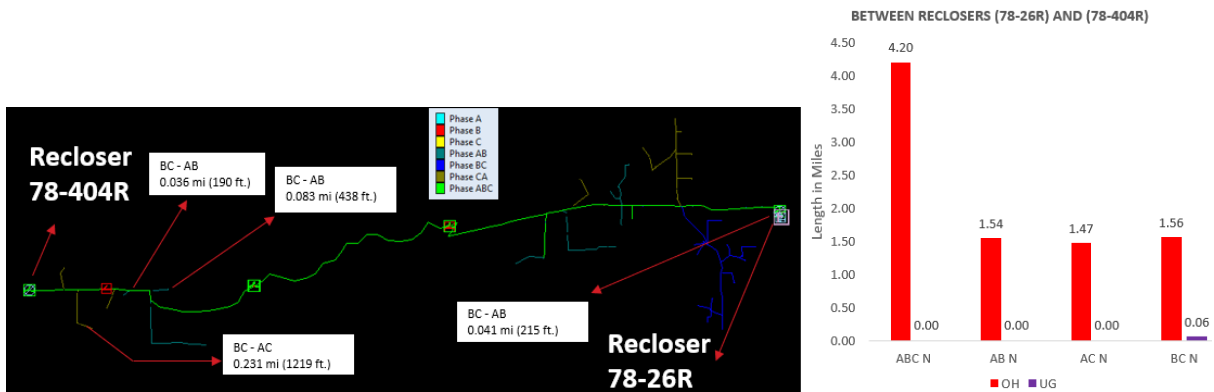


Figure 4-29. Section 1 Phase Swaps on C78

Phase swaps are also performed on sections of circuit 79. Note that this option is not available on all sections of this circuit, as some sections have long 2-phase laterals in such a way that phase swap does not help balancing the circuit.



Figure 4-30 through Figure 4-34 present phase swaps on circuit 79 (multiple sections).

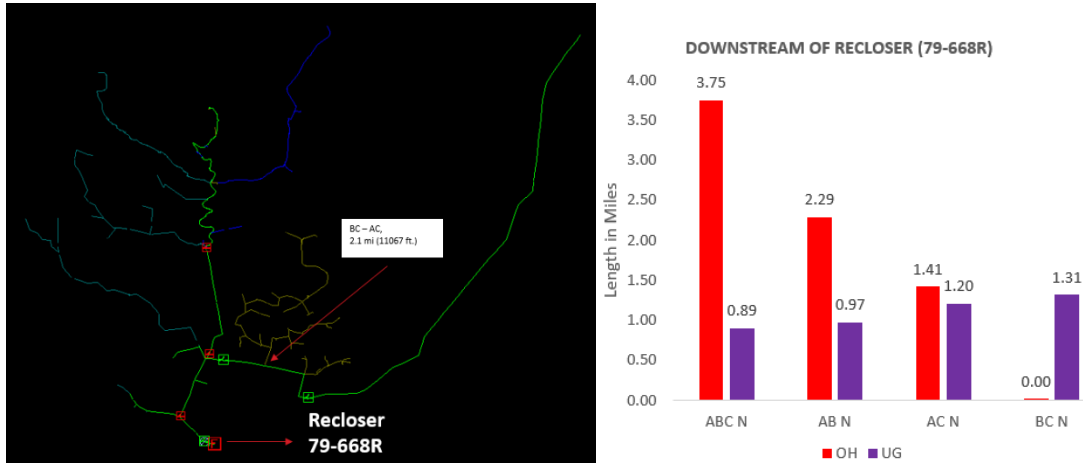


Figure 4-30. Section 7E Phase Swaps on C79

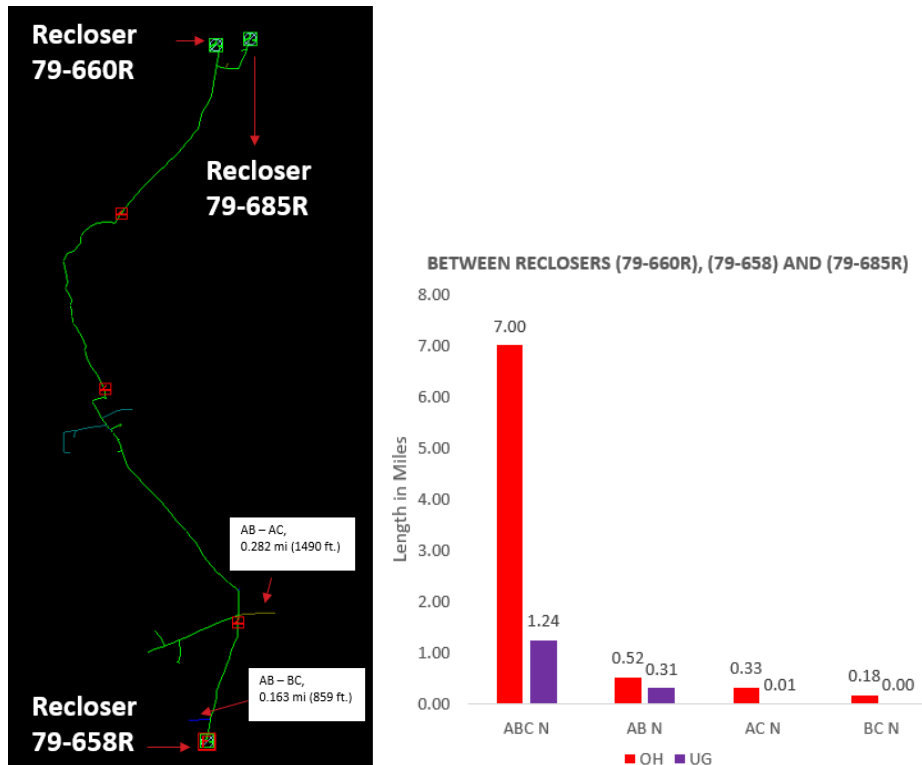


Figure 4-31. Section 4E Phase Swaps on C79

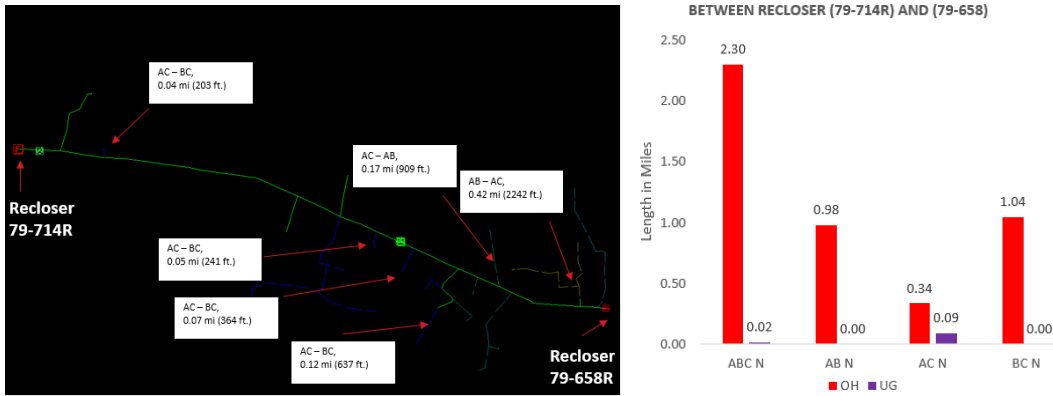


Figure 4-32. Section 3E Phase Swaps on C79

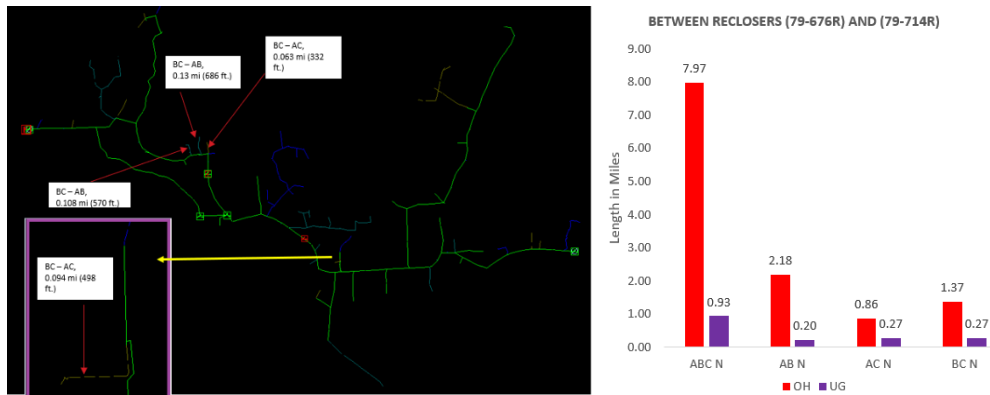


Figure 4-33. Section 2E Phase Swaps on C79

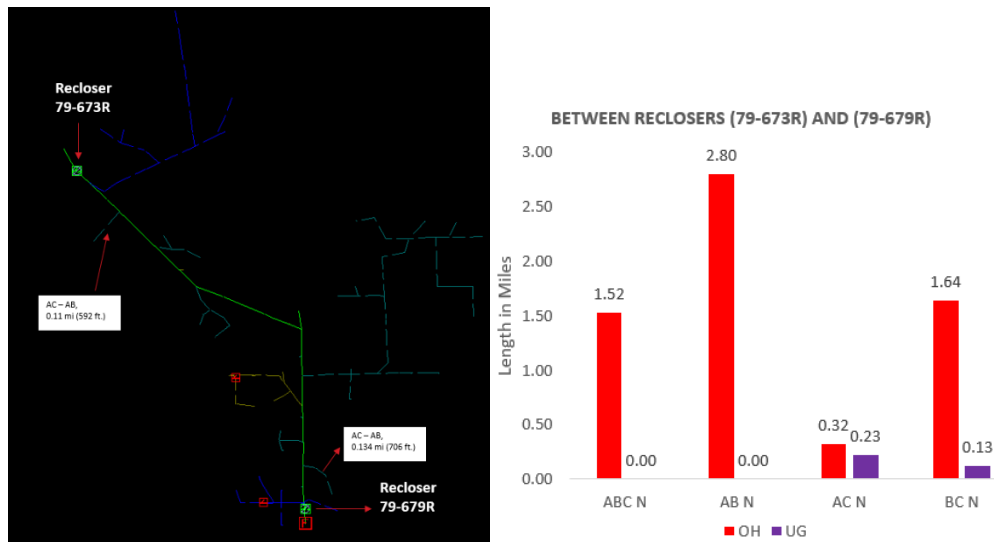


Figure 4-34. Section 8W Phase Swaps on C79



As seen in Table 4-3, applicable phase swaps have helped balance the capacitance values between phases. The total unbalance of the system has improved after performing the phase swaps; however, the unbalance seen at the substation is still 621% (6 times) the required criterion of 0.0348  $\mu\text{F}$  used as the example in this work.

**Table 4-3. Capacitance Values ( $\mu\text{F}$ ) for Different Sections of Descanso Substation After Performing Phase Swaps**

C73	C 78	C79	Substation	Phase A	Phase B	Phase C	Unbalance	Phase
Section	Section	Section	Section	$\mu\text{F}$	$\mu\text{F}$	$\mu\text{F}$	% to 0.0348 $\mu\text{F}$	Swaps
4			1	0.2	0.163	0.199	104%	4
3			2	0.24	0.222	0.16	208%	2
2			3	0.928	0.94	0.87	185%	2
1			4	0.108	0.107	0.106	5%	3
	2		5	0.47	0.431	0.472	114%	4
	1		6	0.062	0.078	0.077	44%	4
		7E	7	0.94	0.983	1.013	182%	1
		6E	8	0.067	0.067	0.061	17%	0
		5E	9	0.017	0.032	0.032	43%	0
		4E	10	0.132	0.127	0.102	80%	2
		3E	11	0.058	0.041	0.059	50%	6
		2E	12	0.228	0.213	0.221	37%	4
		1	13	0	0	0	0%	0
		8W	14	0.099	0.083	0.123	100%	2
		9W	15	0.1	0.006	0.098	266%	0
		10W	16	0.084	0	0.084	240%	0
<b>Sum (seen at the substation)</b>				<b>3.733</b>	<b>3.493</b>	<b>3.677</b>	<b>621%</b>	

#### 4.4.3 Capacitance Values After Performing Phase Swaps and Adding Conductors

Adding a third phase conductor to a 2-phase lateral can help balance the capacitance value of the section to which this lateral belongs. An effort was performed to add such conductor where applicable, and the sections which were targeted using this approach are presented below.



Two sections on circuit 73 were balanced using phase swap as well as an additional conductor as seen in Figure 4-35 and Figure 4-36. Note that this approach is followed on only two sections of C73, as sections 2 and 1 on this circuit cannot be further balanced by the addition of a conductor.

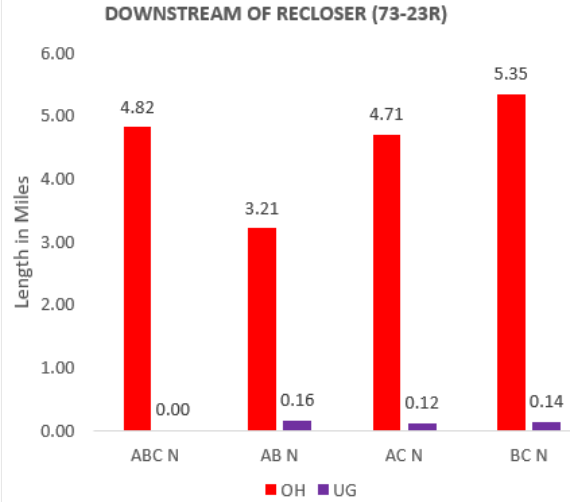
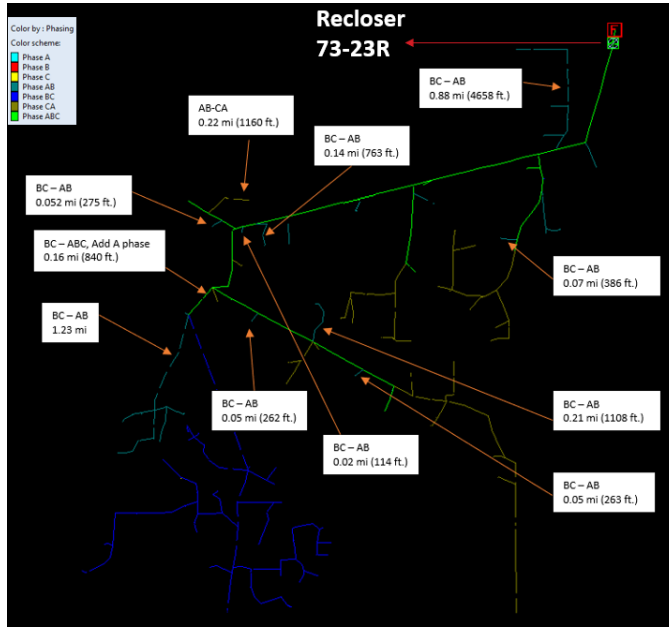


Figure 4-35. Phase Swaps and Additional Conductor on Section 4 of C73

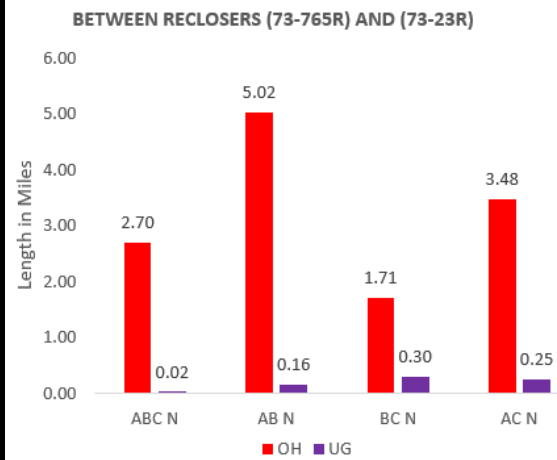
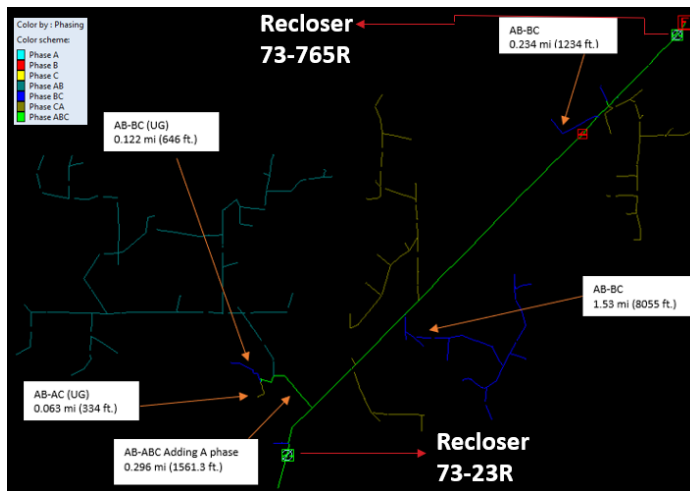


Figure 4-36. Phase Swaps and Additional Conductor on Section 3 of C73





Both sections of circuit 78 can benefit from this approach, as shown in Figure 4-37 and Figure 4-38.

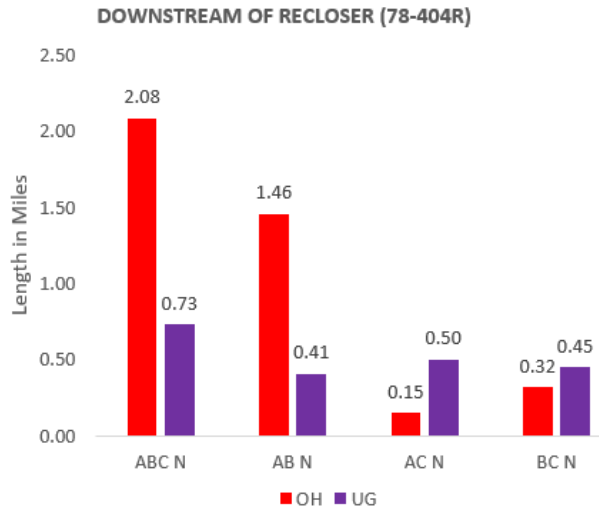
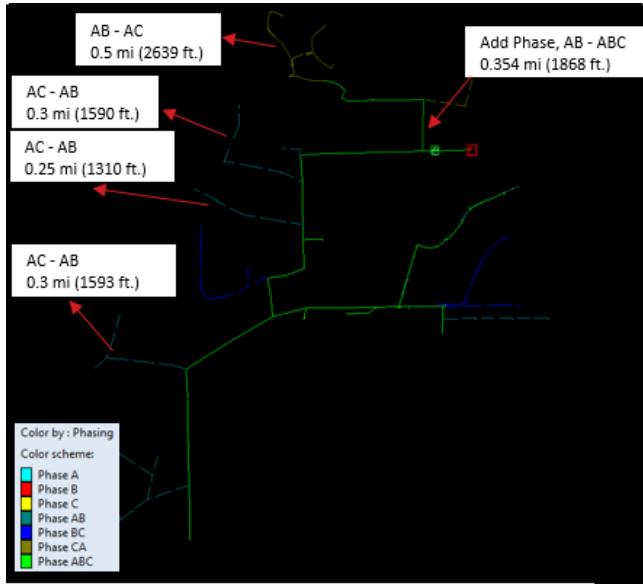


Figure 4-37. Phase Swaps and Additional Conductor on Section 2 of C78

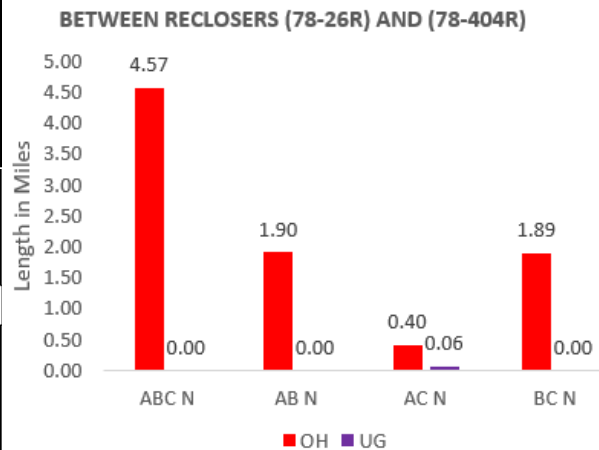
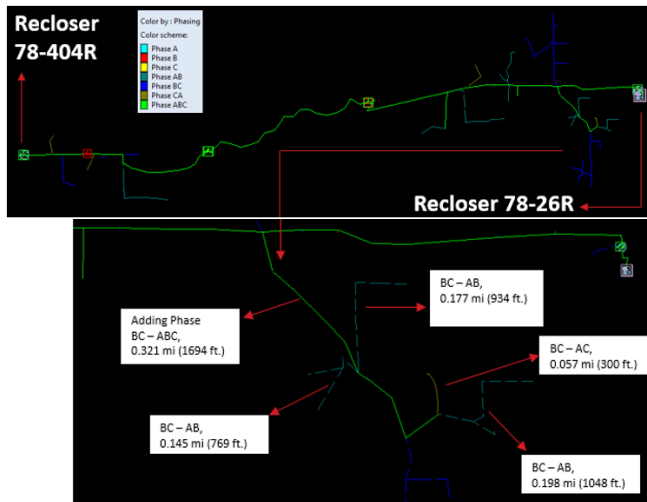


Figure 4-38. Phase Swaps and Additional Conductor on Section 1 of C78



Only two sections of circuit 79 can be further balanced by an additional conductor, as shown in Figure 4-39 and Figure 4-40.

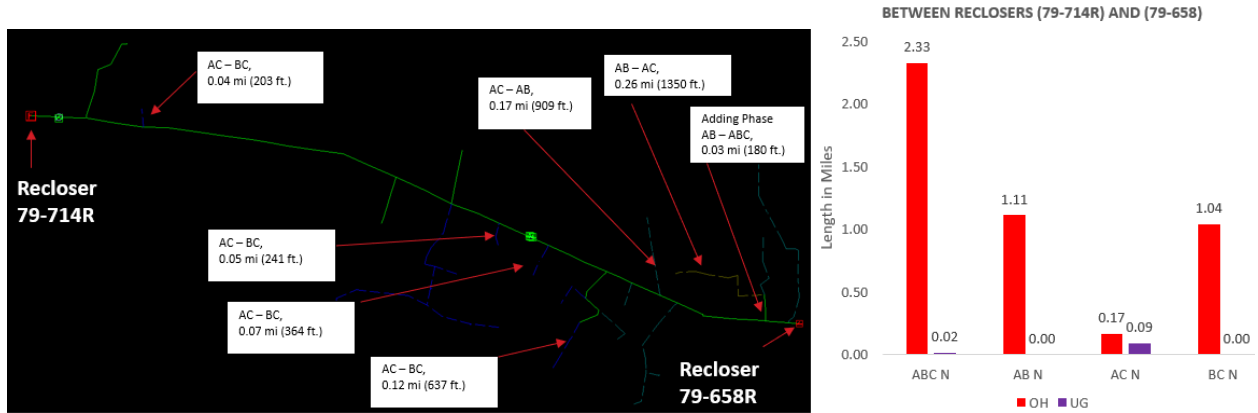


Figure 4-39. Phase Swaps and Additional Conductor on Section 3E of C79

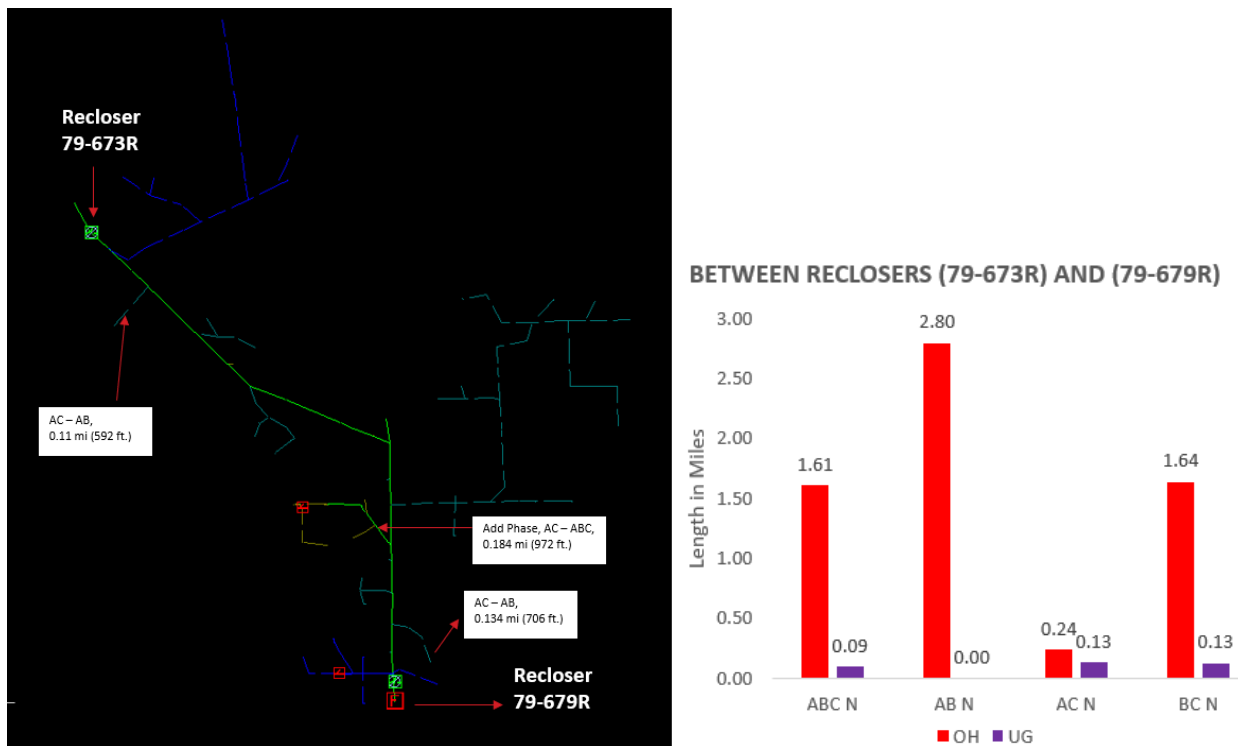


Figure 4-40. Phase Swaps and Additional Conductor on Section 8W of C79



Following the approach of phase swaps and additional conductors for the sections mentioned in Figure 4-35 through Figure 4-40, the results of the capacitance values are presented in Table 4-4.

**Table 4-4. Capacitance values ( $\mu\text{F}$ ) for Different Sections of the Descanso Substation after Performing Phase Swaps as well as the Addition of Conductors**

C73	C 78	C79	Substation	Phase A	Phase B	Phase C	Unbalance	Phase Swaps	Added Conductor Length)
Section	Section	Section	Section	$\mu\text{F}$	$\mu\text{F}$	$\mu\text{F}$	% to 0.0348 $\mu\text{F}$	No.	(ft)
4			1	0.179	0.191	0.194	39%	10	840
3			2	0.207	0.205	0.217	32%	4	1561
2			3	0.928	0.940	0.870	185%	2	0
1			4	0.108	0.107	0.106	5%	3	0
	2		5	0.470	0.459	0.472	35%	4	1868
	1		6	0.074	0.071	0.074	9%	4	1694
		7E	7	0.940	0.983	1.013	182%	1	0
		6E	8	0.067	0.067	0.061	17%	0	0
		5E	9	0.017	0.032	0.032	43%	0	0
		4E	10	0.132	0.127	0.102	80%	2	0
		3E	11	0.058	0.042	0.058	46%	6	180
		2E	12	0.228	0.213	0.221	37%	4	0
		1	13	0.000	0.000	0.000	0%	0	0
		8W	14	0.099	0.109	0.123	60%	2	972
		9W	15	0.100	0.006	0.098	266%	0	0
		10W	16	0.084	0.000	0.084	240%	0	0
<b>Sum (Seen at the substation)</b>				<b>3.691</b>	<b>3.552</b>	<b>3.725</b>	<b>454%</b>		

After performing the phase swaps and adding conductors to balance the system, the total unbalance is improved, but still more than 4 times the required value of 0.0348  $\mu\text{F}$ .



#### 4.4.4 Importance of Each Section and the Studied Configurations

As mentioned earlier, each circuit has different sections depending on the electric location of its reclosers, the circuit breaker, and the circuit end. Circuit 73 has 4 sections, circuit 78 has 2 sections, and circuit 79 has 10 sections. Depending on how these sections are in service, different configurations will take place. Table 4-5 shows the different configurations of each circuit.

Table 4-5. Different Configurations of Circuits on Descanso Substation

C73	C78	C79
Nothing disconnected	Nothing disconnected	Nothing disconnected
Section 4 disconnected	Section 2 disconnected	Section 7E disconnected
Section 4 + 3 disconnected		Section 5E disconnected
Section 4 + 3 + 2 disconnected		Sections 7E and 5E disconnected
		Sections 7E and 6E disconnected
		Sections 7E, 6E and 5E disconnected
		Sections 7E, 6E, 5E, and 4E disconnected
		Sections 7E, 6E, 5E, 4E, and 3E disconnected
		Sections 7E, 6E, 5E, 4E, 3E, and 2E disconnected
		Section 10W disconnected
		Sections 10W and 9W disconnected
		Sections 10W, 9W, and 8W disconnected

Depending on each circuit’s topology as stated in Table 4-5, the substation can see 96 total configurations. For reliable operation of REFCL, the unbalance of capacitance values of three phases (phase to ground values) at the substation in all possible configurations should be less than a specified value that is defined by the required fault detection sensitivity. In this example, a value of 0.0348  $\mu\text{F}$  is used as explained in Section 3.3.1. The methodology for achieving this condition is explained in the next section.

#### 4.4.5 Methodology for Adding Secondary Capacitor Banks

The Capacitance values for each section of the Descanso Substation (its circuits) were presented in Section 4.4 for three different cases: the base case, after considering phase swaps, and the after considering phase swaps and additional conductors. None of these cases meet the criterion of capacitance balancing at the substation. This criterion and the methodology used to verify its successful implementation in proposing solutions will be discussed later. However, the key finding to be presented in this section is that the use of secondary capacitor banks is needed to meet the capacitance balance criterion at the substation and for reliable operation of REFCL in no-fault conditions.

It is necessary to investigate adding a secondary single-phase or double-phase capacitor bank to a maximum of 16 sections on the three circuits so that the capacitance unbalance of three phases (phase



to ground values) at the substation in all possible configurations is less than the value of 0.0348  $\mu\text{F}$ , as stated in Section 3.3.1. The following remarks are to be highlighted:

- The circuits have three possible conditions before installing capacitors:
  - The original configuration of the circuit
  - Circuits after performing phase swaps
  - Circuits after performing both phase swaps and added conductors
- A section is defined as a protection zone on the circuits between reclosers or between a recloser and circuit breaker, or downstream of the farthest recloser(s).
- Capacitors are being installed on 1 or 2 phases in each section.
- We consider steps of 100 var for available capacitor sizes (i.e., we consider capacitor banks of size 100 var, 200 var, etc.).
- C73, C78, and C79 have 4, 2, and 12 configurations based on which of their reclosers are tripped. This yields a total of 96 configurations for the combination of these 3 circuits (substation).
- Tie switches between C73 and C79 can be used and do not impact the total pool of configurations.
- Other ties switches between Descanso circuits and other substations can be used only to pick up the Descanso Substation load. If needed to pick up the load from other substations through Descanso circuits, the REFCL scheme would need to be temporarily disabled.

Since we may not need to place capacitors on all sections, the problem is now defined as determining the sections that need secondary capacitor banks as well as the sizes of the capacitor banks; i.e. determining the size and location of the banks. The following steps are taken to install secondary capacitor banks on a maximum of 16 sections for the substation and its circuits:

1. Capacitance values on the phase of each of the 16 sections are available as input. These are the values before installing the secondary capacitor banks.
2. A total of 96 configurations are considered.
3. The difference between the maximum and minimum capacitance value of the phases of each section is calculated before adding the secondary capacitor banks.
4. The total configurations are checked to meet the criterion for capacitance balance at the substation.
5. The section with the most deviation (most value at step 3) is selected.
6. This section is balanced using secondary capacitor banks. This can be done by adding a capacitor bank to the phase(s) with lower capacitance value to the ground on that section.
7. The balance criterion is checked again after balancing this selected section using capacitor banks.
8. This procedure is followed until the balance criterion is met, or until balancing all sections has been considered.

The flowchart of this algorithm is presented in Figure 4-41. Providing the phase to ground capacitance values of each section of the substation as input, the method tries to balance the sections as mentioned above, to maintain the capacitance unbalance at the substation in all considered configurations below the desired limit. If placing capacitor banks are not satisfying such criterion, the output will be provided as “infeasible result”. This means that further balancing is required with either of these options: choosing



smaller secondary capacitor sizes, performing more phase swaps, or adding more conductors to 2 phase laterals to change them to 3-phase.

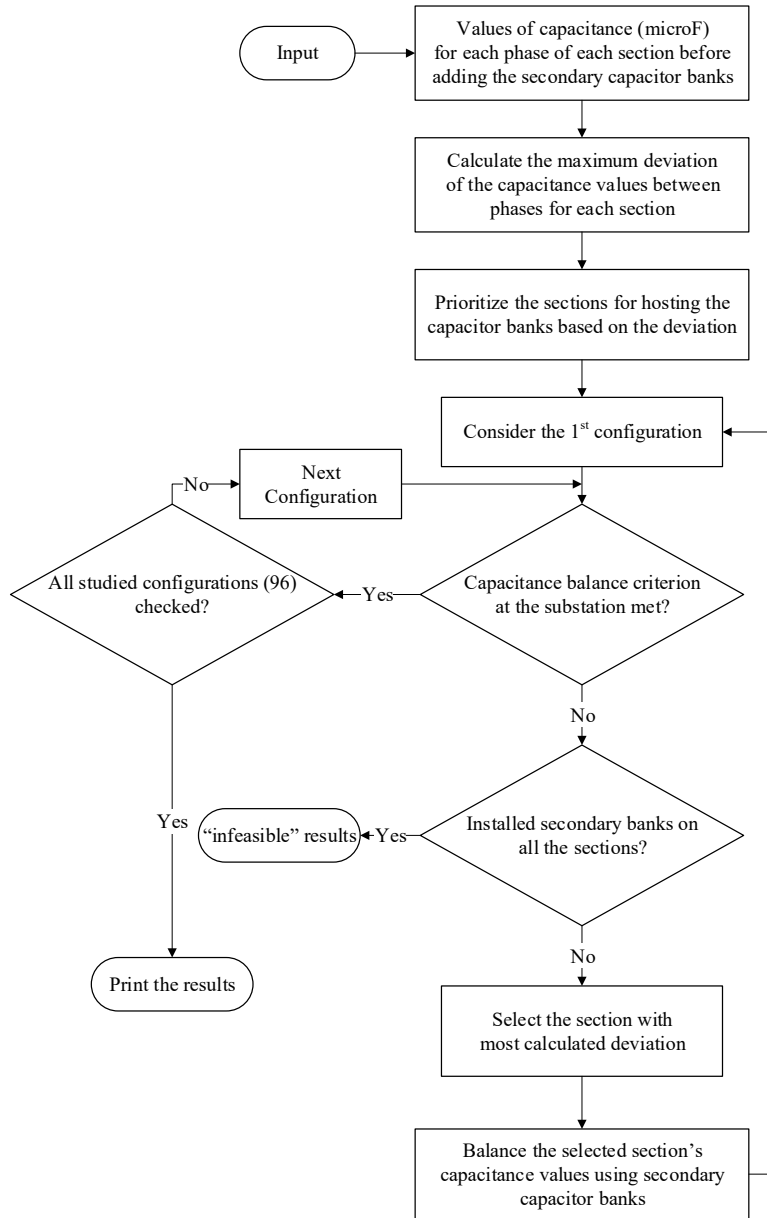


Figure 4-41. Flowchart of the Methodology to Size and Locate the Secondary Capacitor Banks

Installation of capacitor balancing units (CBUs) is performed on the secondary side of a transformer, as shown in Figure 4-42. This figure shows installation of a CBU on phase C of the span shown, through a transformer which is connected at 6.9kV phase to ground. Note that a standard 12kV transformer should be used because it would be exposed to phase to phase voltage when a different phase has a line to



ground fault. Moreover, this transformer must not be used to serve customer load; therefore, the OH pole of this transformer must be tagged accordingly. This configuration should be tested prior to implementation.

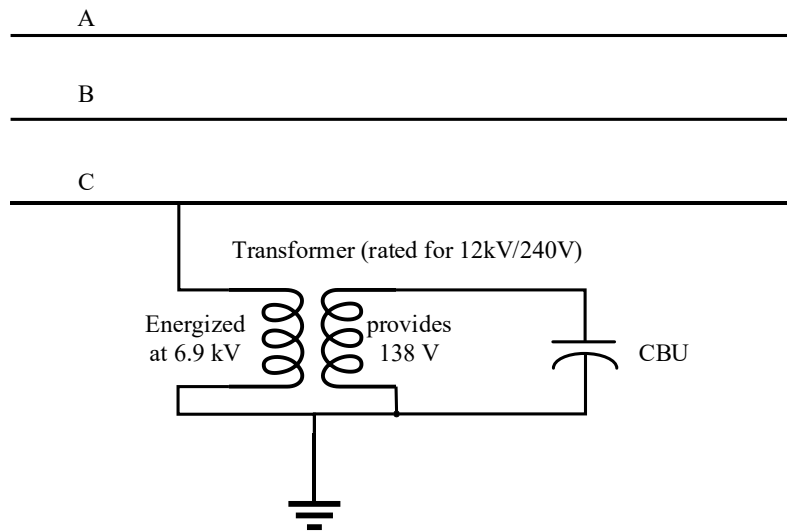


Figure 4-42. Connection of a Secondary Capacitor Bank to Phase C of an OH Span

## 4.5 Results of Capacitance Balancing

Capacitance values of each section of the Descanso Substation (its circuits) were presented in Section 4.4 for three different cases: base case, after performing suggested phase swaps, and after performing both phase swaps and additional conductors. These three different packages were selected as inputs for the algorithm presented in Figure 4-41, and the results were achieved as will be discussed in the following text. The results are hence categorized into three solution packages. All three packages satisfy the capacitance balance requirement at the substation.

### 4.5.1 Solution 1: Capacitor Banks

Table 4-6 shows the results when the base case is considered as the input for the methodology. If no phase swaps or additional conductors are considered, the capacitance values on each phase as stated previously in Table 4-2 would be used as the input for the methodology presented in Figure 4-41. These values are represented here for reference and comparison, in columns 5 to 7 of Table 4-6. The next three columns present the capacitance values of each section after utilizing secondary capacitors. These values satisfy the balance requirement at the substation. The last three columns present the size and location of the secondary banks needed on each phase of each section to achieve this satisfactory condition.



Table 4-6. Base Case Before Installing Secondary Banks and After Installing Them (Solution 1)

C73	C78	C79	Substa- tion	Capacitance Values on Each Phase BEFORE Adding the Secondary Banks (µF)			Capacitance Values on Each Phase AFTER Adding the Secondary Banks (µF)			Unbalance  % to 0.0348 µF	Size of the Secondary Banks ADDED in the Process (var)		
				A to Ground	B to Ground	C to Ground	A to Ground	B to Ground	C to Ground		A to Ground	B to Ground	C to Ground
4			1	0.131	0.224	0.207	0.219	0.224	0.224	14%	1600	0	300
3			2	0.300	0.222	0.100	0.300	0.299	0.299	3%	0	1400	3600
2			3	0.949	0.948	0.840	0.949	0.948	0.945	10%	0	0	1900
1			4	0.117	0.100	0.104	0.117	0.100	0.104	44%	0	0	0
	2		5	0.510	0.456	0.408	0.510	0.506	0.507	10%	0	900	1800
	1		6	0.058	0.080	0.078	0.058	0.080	0.078	60%	0	0	0
		7E	7	0.735	1.189	1.013	1.188	1.189	1.184	13%	8200	0	3100
		6E	8	0.067	0.067	0.061	0.067	0.067	0.061	17%	0	0	0
		5E	9	0.017	0.032	0.032	0.017	0.032	0.032	43%	0	0	0
		4E	10	0.133	0.133	0.094	0.133	0.133	0.133	0%	0	0	700
		3E	11	0.061	0.063	0.034	0.061	0.063	0.034	80%	0	0	0
		2E	12	0.132	0.255	0.275	0.270	0.272	0.275	12%	2500	300	0
		1	13	0.000	0.000	0.000	0.000	0.000	0.000	0%	0	0	0
		8W	14	0.099	0.081	0.125	0.121	0.120	0.125	13%	400	700	0
		9W	15	0.100	0.006	0.098	0.100	0.100	0.098	6%	0	1700	0
		10W	16	0.084	0.000	0.084	0.084	0.083	0.084	3%	0	1500	0
<b>Sum (Seen at the substation)</b>							<b>4.194</b>	<b>4.216</b>	<b>4.183</b>	<b>83%</b>			

With the additional installation of secondary banks, the unbalance for the base case could be reduced to a value that is enough for the specified sensitivity in this example. The total unbalance as seen by the substation in the configuration where all sections are energized is less than the selected value of 0.0348 µF (83% of such value).

#### 4.5.2 Solution 2: Phase Swaps and Capacitor Banks

When phase swaps are performed to balance out the sections, capacitance values per section are achieved as mentioned previously in Table 4-3. Providing the methodology presented in Figure 4-41 with these values as input, results in the capacitance values needed on every phase of all sections to satisfy the capacitance balance criterion at the substation. This is presented in Table 4-7, where the three last columns provide sizes and locations of the required secondary capacitor banks in VAr. With performing phase swaps and the additional installation of secondary capacitor banks, the unbalance could be even more reduced compared with the previous case: the total unbalance at the substation when all sections are energized is now 45% of the required value of 0.0348 µF.





**Table 4-7. Results of Phase Swaps Before Installing Secondary Banks and After Installing Them (Solution 2)**

C73	C78	C79	Substa- tion	Capacitance Values on Each Phase BEFORE Adding the Secondary Banks (μF)			Capacitance Values on Each Phase AFTER Adding the Secondary Banks (μF)			Unbalance  % to 0.0348 μF	Size of the Secondary Banks ADDED in the Process (var)		
				A to Ground	B to Ground	C to Ground	A to Ground	B to Ground	C to Ground		A to Ground	B to Ground	C to Ground
4			1	0.200	0.163	0.199	0.200	0.196	0.199	10%	0	600	0
3			2	0.240	0.222	0.160	0.240	0.239	0.237	8%	0	300	1400
2			3	0.928	0.940	0.870	0.939	0.940	0.936	10%	200	0	1200
1			4	0.108	0.107	0.106	0.108	0.107	0.106	5%	0	0	0
	2		5	0.470	0.431	0.472	0.470	0.470	0.472	6%	0	700	0
	1		6	0.062	0.078	0.077	0.062	0.078	0.077	44%	0	0	0
		7E	7	0.940	0.983	1.013	1.012	1.011	1.013	5%	1300	500	0
		6E	8	0.067	0.067	0.061	0.067	0.067	0.061	17%	0	0	0
		5E	9	0.017	0.032	0.032	0.017	0.032	0.032	43%	0	0	0
		4E	10	0.132	0.127	0.102	0.132	0.127	0.102	80%	0	0	0
		3E	11	0.058	0.041	0.059	0.058	0.041	0.059	50%	0	0	0
		2E	12	0.228	0.213	0.221	0.228	0.213	0.221	37%	0	0	0
		1	13	0.000	0.000	0.000	0.000	0.000	0.000	0%	0	0	0
		8W	14	0.099	0.083	0.123	0.121	0.122	0.123	5%	400	700	0
		9W	15	0.100	0.006	0.098	0.100	0.100	0.098	6%	0	1700	0
		10W	16	0.084	0.000	0.084	0.084	0.083	0.084	3%	0	1500	0
<b>Sum (Seen at the substation)</b>							<b>3.838</b>	<b>3.826</b>	<b>3.820</b>	<b>45%</b>			

### 4.5.3 Solution 3: Phase Swaps, Additional Conductors, and Capacitor Banks

If phase swaps as well as adding extra conductors are completed to balance the system before adding secondary capacitor banks, capacitance values for each section of the studied circuits would be as mentioned previously in Table 4-4. Providing the methodology presented in Figure 4-41 with these values as input, shows the values and sizes of capacitor banks which are to be added on each section in order to meet the capacitance balance criterion at the substation as mentioned in the last three columns of Table 4-8. This solution requires less kVAR contribution from the secondary capacitor banks and the total unbalance at the substation is less than the required limit of 0.0348 μF.



**Table 4-8. Results of Phase Swaps and Additional Conductors Before Installing Secondary Banks and After Installing Them (Solution 3)**

C73	C78	C79	Substa- tion	Capacitance Values on Each Phase BEFORE Adding the Secondary Banks (µF)			Capacitance Values on Each Phase AFTER Adding the Secondary Banks (µF)			Unbalance  % to 0.0348 µF	Size of the Secondary Banks ADDED in the Process (var)		
				A to Ground	B to Ground	C to Ground	A to Ground	B to Ground	C to Ground		A to Ground	B to Ground	C to Ground
4			1	0.179	0.191	0.194	0.179	0.191	0.194	39%	0	0	0
3			2	0.207	0.205	0.217	0.207	0.205	0.217	32%	0	0	0
2			3	0.928	0.940	0.870	0.939	0.940	0.936	10%	200	0	1200
1			4	0.108	0.107	0.106	0.108	0.107	0.106	5%	0	0	0
	2		5	0.470	0.459	0.472	0.470	0.459	0.472	35%	0	0	0
	1		6	0.074	0.071	0.074	0.074	0.071	0.074	9%	0	0	0
		7E	7	0.940	0.983	1.013	1.012	1.011	1.013	5%	1300	500	0
		6E	8	0.067	0.067	0.061	0.067	0.067	0.061	17%	0	0	0
		5E	9	0.017	0.032	0.032	0.028	0.032	0.032	11%	200	0	0
		4E	10	0.132	0.127	0.102	0.132	0.127	0.130	12%	0	0	500
		3E	11	0.058	0.042	0.058	0.058	0.053	0.058	14%	0	200	0
		2E	12	0.228	0.213	0.221	0.228	0.224	0.227	10%	0	200	100
		1	13	0.000	0.000	0.000	0.000	0.000	0.000	0%	0	0	0
		8W	14	0.099	0.109	0.123	0.121	0.120	0.123	8%	400	200	0
		9W	15	0.100	0.006	0.098	0.100	0.100	0.098	6%	0	1700	0
		10W	16	0.084	0.000	0.084	0.084	0.083	0.084	3%	0	1500	0
<b>Sum (Seen at the substation)</b>				<b>3.807</b>	<b>3.790</b>	<b>3.825</b>	<b>87%</b>						

#### 4.5.4 Comparison Between Solution 1, 2, and 3

Table 4-9 compares all three of the solution packages. It summarizes and compares the action items that need to be completed. The following observations are made from Table 4-9.

- A total of 16 installations of secondary capacitor banks are needed in solution 1. These installations are a total of 30.6kVAr.
- Performing phase swaps before utilizing secondary capacitor banks reduces the number of installations from 16 in solution 1 to 12 in solution 2. This helps reduce the total kVAr required from the capacitor banks, i.e. the summation of sizes of secondary capacitor banks is reduced by around 20 kVAr. Note that the 34 total phase swaps are performed in 11 sections of the substation and its circuits, as shown previously in Figure 4-24 through Figure 4-34.



- If the option of adding conductors is available, the capacitance values of the sections can be further balanced prior to utilizing the capacitor banks. This leads to a reduction in the total kVar needed from the secondary capacitor banks to a value of 8.2kVar. In this solution package, 7115 ft of the conductors are added to 6 sections of the substation and its circuits, as well as 42 phase swaps in 11 sections. The location of these phase swaps and the added conductors are shown previously in Figure 4-35 through Figure 4-40.
- At this time, SDG&E does not see installing additional overhead conductors for phase balancing as an acceptable solution because it only exacerbates the exposure of overhead equipment to potential fire ignition risk. Therefore, secondary capacitor banks with or without phase swaps will be assumed as the two selected solutions for balancing 12kV distribution capacitance and the related costs will be presented in the next section.

Table 4-9. Comparison of Three Solution Packages

Related to	Description	Solution 1	Solution 2	Solution 3
<b>Secondary Capacitor Banks</b>	Number of total capacitor banks	16	12	13
	Total kVar from capacitor banks	30.6	10.5	8.2
<b>Phase Swaps</b>	Sections having phase swaps	0	11	11
	Total phase swaps	0	34	42
<b>Additional Conductor</b>	Sections having added conductor	0	0	6
	Total conductor added (ft)	0	0	7115

#### 4.6 Estimated Cost for Capacitance Balancing

The cost estimate for presented solutions 1 and 2 are provided in this section (see Table 4-10). Solution 3 was not considered as it did not provide any additional value. The following assumptions are made:

- Daily crew rates for both phase swaps and installing secondary capacitor banks are based on SDG&E WOR-C for “OH Working Foreman Four-Man Crew”.
- Single-phase capacitor banks are used in the solution packages provided. For sections requiring the installation of secondary capacitor banks on two phases, one single-phase capacitor bank is installed per phase.
- Each secondary capacitor bank has adjustable VAr settings and each costs \$3,150.
- Each secondary capacitor bank is installed with a standard 25kVA pole-top transformer. The cost for a 25kVA transformer, 1 phase, is \$1531.
- A contingency of 30% is included for the final cost values.
- For this cost estimate, it is assumed that a maximum of 2 single-phase secondary capacitor banks can be installed per day.



**Table 4-10. Cost Estimate for Solution 1 and 2 of Capacitance Balancing**

Solution	Circuit	Number of phase swaps	Cost of phase swaps	Number of single-phase capacitor banks	Total kVar	Cost of capacitor banks	Total Cost
Solution 1	73	Not applicable	\$0	5	8.8	<b>\$73,440</b>	
	78	Not applicable	\$0	2	2.7	<b>\$29,376</b>	
	79	Not applicable	\$0	9	19.1	<b>\$132,193</b>	
<b>Total Solution 1</b>		<b>0</b>	<b>\$0</b>	<b>16</b>	<b>30.6</b>	<b>\$235,009</b>	<b>\$235,009</b>
Solution 2	73	11	\$63,092	5	3.7	<b>\$73,440</b>	
	78	8	\$45,885	1	0.7	<b>\$14,688</b>	
	79	15	\$86,033	6	6.1	<b>\$88,129</b>	
<b>Total Solution 2</b>		<b>34</b>	<b>\$195,010</b>	<b>12</b>	<b>10.5</b>	<b>\$176,257</b>	<b>\$371,267</b>

## 4.7 Other Considerations

Other considerations concerning the assumptions and use of the Synergi model are discussed in this section.

### 4.7.1 Circuits' Phase Identification

The model studied for the Descanso circuits is provided by SDG&E in the Synergi software. In all efforts to balance the capacitance between three phases, this model has been used as the reference. Prior to REFCL implementation, the capacitance balancing analysis needs to be re-done using accurate field data. One important characteristic of the circuit is how the phases are spread along the circuit which can affect the results of capacitance balance significantly. To make sure the model is accurately representing the circuit concerning the phase identification of the spans (whether OH or UG), the following comments are highlighted, which can be combined by a further investigation performed by SDG&E to verify their Synergi model.

- Phase identification can be performed at the substation and circuit head to verify phase locations on the poles and identify phases on underground spans.
- SDG&E can utilize its standard AP30 Phase Trakker Phase Identifier as needed for remote locations where phases cannot be visually identified via substation getaways.
- Certain poles at corners or dead-ends should be checked to verify whether a transposition of conductors had been done.
- How the 2-phase laterals are branched off from the 3-phase trunk or spans is important as it can specify which phases are derived from the 3-phase span. An example of this can be found at pole P172677 on C78. This branch is identified as phase CA in the Synergi model obtained from SDG&E, as shown in Figure 4-43. Having initially followed the conductor locations on previous poles starting from



the circuit head, verification is needed to confirm which phases are branched off from the 3-phase span. A street view obtained from Google shows the branch as in Figure 4-44.

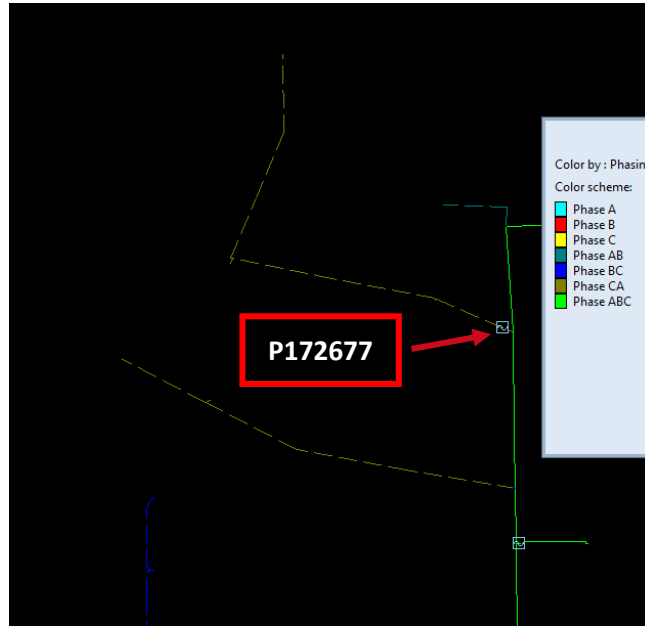


Figure 4-43. Synergi Phasing of Area Including P172677 on C78

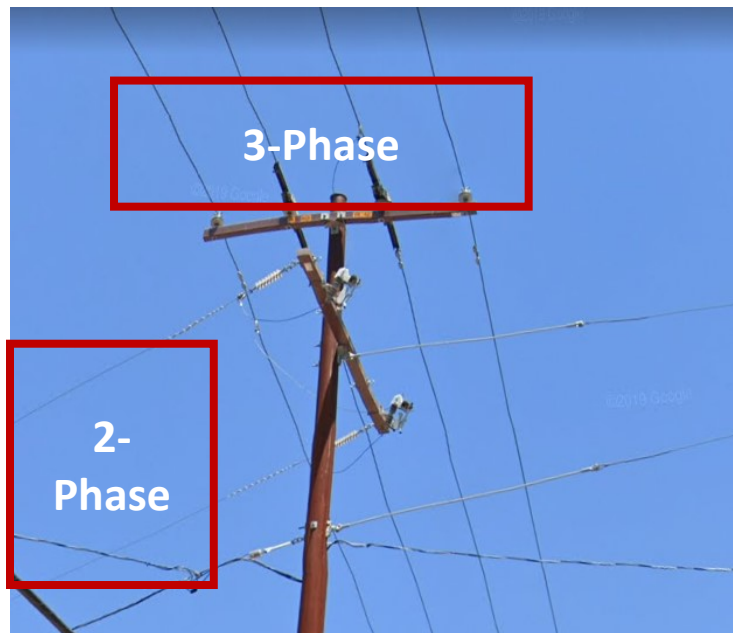


Figure 4-44. Google Street View at P172677 on C78



#### 4.7.2 Impact of Fuse Operations

The fuse operation on two-phase laterals can change the capacitance values of the section and hence the capacitance values seen at the substation. In this work, we have considered the criterion for capacitance balance at the substation to be 0.0348  $\mu\text{F}$  as an example, as discussed earlier in Section 3.3.1. Hence, the total capacitance unbalance, when the fuse is operated and the two-phase lateral is de-energized, should still be within this limit.

As an example, in the solution 1 package presented previously in Table 4-6, the capacitance unbalance at the substation is different for each of the 96 considered configurations. However, all such values are below the desired limit of 0.0348  $\mu\text{F}$  as stated in Section 3.3.1. The configuration in which all sections are energized has the capacitance unbalance of 0.028  $\mu\text{F}$ . Considering this configuration only, the capacitance values before fuse operation are different in the three phases as seen by the substation. These are shown in Table 4-11 in the first three columns. Based on which two phases are to be disconnected by fuse operation, different values are obtained for the maximum allowable length of the spans being disconnected by the fuse operation. These values are shown in the next three columns in Table 4-11. For instance, if a 2-phase lateral of phases A and C are to be disconnected by the fuse in the aforementioned solution and configuration, the length should be less than 4,715 ft for a fused OH lateral of type #4 B.STRD, or 142 ft for an underground lateral of type #2 PECN-PEJ AL.

**Table 4-11. Allowed Length of Laterals for Fuse Operation for 1 OH and 1 UG Example of a 2-Phase Lateral in Three Cases (Phase AC, AB, or BC) in Solution 1 Package When All Sections are Energized**

Total Capacitance ( $\mu\text{F}$ ) Before Fuse Operation in Solution 1, Configuration 1 (All Sections are Energized)			Allowed Capacitance Change to Maintain the Balance Criterion ( $\mu\text{F}$ )			Length of the Fused Lateral to Maintain Balance (ft)		
Phase A	Phase B	Phase C	Phase A	Phase B	Phase C	Phasing of the Lateral	#4 B.STRD	#2 PECN-PEJ AL
4.194	4.216	4.183	NA	0.025	0.025	BC	16,737	501
			0.052	0.052	NA	AB	34,425	1,029
			0.007	NA	0.007	AC	4,715	142

Therefore, prior to REFCL implementation and after restudying the capacitance balancing analysis using accurate field data and accurate phase identification, all considered configurations (for instance, the 96 considered configuration in this work) of the selected solution package should be studied with respect to the allowable fuse operations. When needed, fuses whose operation violates the capacitance balance requirement in any configuration should be considered for removal or bypass.



### 4.7.3 Capacitance Field Measurements

Specific consideration is required for accurate measurement and verification of capacitive balancing at the substation as well as the location of reclosers throughout the feeders. As stated earlier, the REFCL concept relies on the zero-sequence voltage  $V_0$  for the ground fault detection; that is, at the normal operation mode, the zero-sequence voltage  $V_0$  should be below a determined level. The required threshold for  $V_0$  can be calculated based on the required sensitivity for the fault detection (see Section 3.3.1).

For the reduction of the zero-sequence voltage during normal conditions, capacitance balancing procedure and calculations were proposed, and results were presented above. The proposed procedures and calculations were based on the circuit models in Synergi. Therefore, careful model verifications including, but not limited to, phase identification should be performed prior to implementation of circuit balancing activities, followed by field verification of the actual system unbalance of the circuits and their sections.

The measurement of the capacitive system unbalance can be performed in the substation. All load on this circuit must be connected phase to phase. In a solidly grounded system, the measurement of the current through the neutral connection can be used to determine the capacitive unbalance:

$$I_{Neutral} = \frac{V_N}{\sqrt{3} \cdot \omega \Delta C} \quad [\text{Eq. 4-3}]$$

Where:

$\Delta C$ : capacitive asymmetry in the system

$V_n$ : nominal system voltage (phase to phase)

$\omega$ : angular frequency ( $2 \cdot \pi \cdot 60$  Hz)

The value of this current is typically less than 1A and therefore the accuracy class of the CT used for this measurement must support this range. Unlike the substation where this direct measurement of neutral current is available, since the summation of three-phase CTs in a Holmgren circuit for the measurement of  $I_0$  will not be accurate enough for this purpose, measuring the neutral currents on the feeder without access to the neutral is a challenge.

If the capacitive unbalance of a section needs to be determined, the special core balanced or window CTs are required for an accurate measurement. Alternatively, the measurements in the substation can be used and the delta of unbalance measurements when the section is switched in and/or out can be used to determine the unbalance of the studied section.

A measuring system's capacitive unbalance in ungrounded or REFCL grounded systems is more complex. The measurements of  $V_0$  between the transformer neutral and ground can be used to evaluate the system unbalance; however, the value of the capacitance system unbalance  $\Delta C$  can only be calculated if the system resistive losses shown as  $R_N$  in Figure 4-45 are known. The system losses consist of resistive losses of the arc suppression coil and the surge arresters in the system.



In a system where the capacitance  $C_0$  is 100% compensated by the arc suppression coil  $X_N$ ,  $C_0$  in parallel with  $X_N$  can be assumed as an infinite impedance; therefore,  $I_0$  is calculated as  $V_0/R_N$ . Knowing that  $I_0 = 3 \cdot I_{Neutral}$ , the same formula (Eq. 4-3) as discussed for grounded systems can be applied to calculate system capacitance unbalance, denoted by  $\Delta C$ . For such calculation, the system losses value denoted by  $R_N$  in Figure 4-45 needs to first be measured or calculated based on an accurate system model.

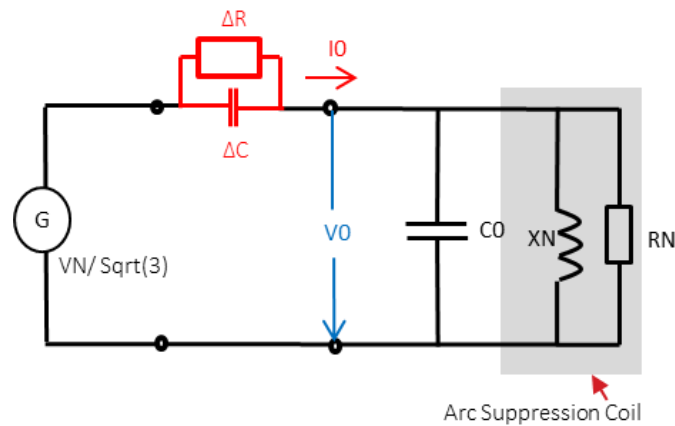


Figure 4-45. Equivalent Circuit for ASC Grounded System

In ungrounded or REFCL grounded systems, previous methods discussed in grounded systems which used special core balanced or window CTs for measurements of capacitance unbalance of only one feeder section is not feasible, and the only way to achieve such value is the measurement of  $V_0$  when switching a section in and out to calculate the delta of  $V_0$  as a metric for the unbalance of that section.





## 5 12KV FEEDERS EQUIPMENT RATING EVALUATION

Similar to previous tasks performed on the substation equipment, the distribution system equipment specifications were also closely evaluated. The equipment evaluations described in this section of the report present the existing equipment's capability to operate with the REFCL equipment. SDG&E data and industry standards were reviewed that are related to phase-to-ground and phase-to-phase voltage withstand capabilities for the following equipment inclusive to this section of the report.

Important information was obtained from Swedish Neutral during the discovery period. The SDG&E installation of the overhead neutral conductors can remain in service during REFCL operation without interfering with the REFCL algorithm in the REFCL control and monitoring unit.

Documents reviewed included SDG&E's "2019 Electric Distribution Design Manual", "2019 Overhead Construction Standards", "2019 Underground Construction Standards", and all other available data provided by SDG&E.

### 5.1 Overhead System Equipment

#### 5.1.1 12-kV Feeders Equipment Rating Evaluation

The reason for evaluating the 12kV feeder equipment voltage ratings is that whenever a ground fault occurs on the distribution system, the Swedish Neutral REFCL response creates voltage stress on any downstream distribution line equipment connected to the un-faulted phases. This voltage stress may lead to a second fault, especially if the overvoltage exceeds the voltage ratings of any downstream equipment such as equipment bushings, voltage regulators, surge arresters, reclosers, capacitor banks, underground cables, and their associated connectors. If this equipment is not rated appropriately, then the REFCL installation may further increase fire risk after the initial REFCL response.

The comparison of the equipment and ratings provide an initial assessment. High voltage testing of sample equipment can help confirm whether the equipment can withstand the overvoltages or whether they require replacement.

##### 5.1.1.1 Voltage Regulators

Identify voltage regulators (VR) and their field configuration to determine if it needs replacement – this is inclusive of the controller:

- According to Synergi, feeders C78 and C79 each have a 3-Phase Voltage Regulator unit per feeder.
- Feeder C78 has a 3 Single Phase Voltage Regulator w/Controller – Closed Delta [No Replacement Required] at pole location 78-395G1, 78-395G2, 78-395G3.
- Suggest using one VR controller to maintain balancing of the feeder circuits
- Feeder C79 has a 3 Single Phase Voltage Regulator w/Controller – [Unknown High-Side Configuration] the Voltage Regulator is at pole location 79- 793G1, 79- 793G2, 79- 793G3.



- Feeder C79 Voltage regulators are assumed to be connected line-to-ground per SDG&E OH1311.2, Sheet 2 of 2, Note II. January 2018 and newer “GH” Regulators will be tapped to the 6,930V Position with 3 Single-phase VRs and 3 independent VR controllers.
- Suggest reconfiguring of Feeder C79 VRs from Wye-Ground to Closed Delta configuration with parallel control using one VR controller to maintain balancing of the feeder circuits.

**5.1.1.2 Transformers (including 12/4kV)**

Focused on the review of feeders C73, C78, and C79 and using SDG&E company data, there are no 4kV transformers on these circuits. During the review of SDG&E company standards along with IEEE standards on transformer bushings related to phase-to-ground and phase-to-phase voltage withstand capabilities, it was determined that transformers and their bushing are capable of handling the continuous and temporary overvoltages associated with the deployment of the Swedish Neutral REFCL protection system.

An example of the insulation levels for distribution transformers used on the SDG&E system reveals that the transformers are rated at a nominal system voltage of 15kV, and the maximum system voltage these transformers can withstand is 17kV RMS. “Table 3” (Figure 5-1) presents the dielectric insulation levels for the distribution transformers [7].

**Table 3—Dielectric insulation levels for distribution and Class I power transformers, voltages in kV**

Maximum system voltage (kV rms)	Nominal system voltage <sup>a, g</sup> (kV rms)	Applied voltage test <sup>f</sup> (kV rms)			Induced voltage test <sup>b, f</sup> (phase to ground) (kV rms)	Winding line-end BIL <sup>c, f</sup> (kV crest)			Neutral BIL <sup>d, f, h</sup> (kV crest)	
		Delta or fully insulated wye	Grounded wye	Impedance grounded wye or grounded wye with higher BIL		Minimum	Alternates	Grounded wye	Impedance grounded wye or grounded wye with higher BIL	
Col 1	Col 2	Col 3	Col 4	Col 5	Col 6	Col 7	Col 8	Col 9	Col 10	Col 11
<b>Distribution transformers</b>										
1.5	1.2 <sup>e</sup>	10	—	10	1.4	<b>30</b>			30	30
3.5	2.5 <sup>e</sup>	15	—	15	2.9	<b>45</b>			45	45
6.9	5 <sup>e</sup>	19	—	19	5.8	<b>60</b>			60	60
11	8.7 <sup>e</sup>	26	—	26	10	<b>75</b>			75	75
17	15	34	—	34	17	<b>95</b>	110		75	75
26	25	40	—	40	29	<b>125</b>	<b>150</b>		75	95
36	34.5	50	—	50	40	125	<b>150</b>	<b>200</b>	75	125
48	46	95	—	70	53	200	<b>250</b>		95	150
73	69	140	—	95	80	250	<b>350</b>		95	200

**Figure 5-1. Dielectric Insulation Levels for Distribution Transformers [7]**

According to [7], the values listed as nominal system voltage in some cases apply to other lesser voltages of approximately the same value (e.g., 15kV encompasses nominal system voltages of 14.44kV, 13.8kV, 13.2kV, 13.09kV, 12.6kV, 12.47kV, 12kV, 11.95kV).



It was identified that sixteen (16) pole-mounted overhead transformers on feeder C79 may require reconfiguration from open-delta to closed-delta prior to the deployment of the Swedish Neutral REFCL system.

#### 5.1.1.3 Bushings

According to [7], the transformers are equipped with bushings with an insulation level no less than that of the winding terminal to which it is connected. This remains consistent unless otherwise specified and bushings for use in transformers have impulse and low-frequency insulation levels as listed in Table 9 of the IEEE Standard C57.19.01.

Faults produce temporary, power frequency, phase-ground overvoltages on the un-faulted phases according to [8]. Temporary overvoltages between phases or across longitudinal insulation normally do not occur. The magnitude of an overvoltage depends on system grounding and fault location.

Among effectively grounded systems, temporary overvoltage is about 1.3 per unit and the duration of the overvoltage, considering backup clearing, is generally less than 1 second. In resonant grounded systems temporary overvoltage is about 1.73 per unit (phase to phase) or greater and with fault clearing, the duration is typically less than 10 seconds.

According to “Table 9” (Figure 5-2) the “Rated frequency withstand” column identifies the maximum RMS value of the voltage that a Distribution Transformer connected to the power system can withstand permanently. For the 12kV system voltage at SDG&E, for example, the distribution transformers rated at 15kV, the rated power frequency withstand voltage, RMS value, kV for 1 minute is 35kV. This value defines the maximum level of RMS overvoltage that the SDG&E distribution transformers may withstand for 1 minute. Therefore, in the REFCL operation, the bushings on the SDG&E distribution transformers will withstand a line-to-line voltage of 12kV. This withstand voltage is what a new and clean bushing is capable of withstanding for 1 minute, but if there are older and dirty distribution transformers, then these distribution transformers may have to be removed and lab tested by vintage to verify they can withstand the rated frequency voltage as shown in “Table 9” (Figure 5-2).

- The rated maximum line-to-ground voltage, per [9] is the highest RMS rated frequency voltage between the conductor, the mounting flange and bushing, and is designed to operate continuously.
- The rated continuous current is the RMS current at the rated frequency that a bushing shall be required to carry continuously under specified conditions without exceeding the permissible temperature limitations.



**Table 9—Electrical insulation characteristics of transformer bushings (applies only to bushings 34.5 kV and below not listed in IEEE Std C57.19.01 )**

Outdoor bushing							Indoor bushings <sup>a</sup>		
Power transformers <sup>b</sup>					Distribution transformers <sup>b</sup>				
System voltage <sup>c</sup>	Minimum creepage distance	Rated frequency withstand		Impulse full wave dry withstand (kV)	Rated frequency withstand		Impulse full wave dry withstand (kV)	Rated frequency withstand 1 min dry	Impulse full wave dry withstand (kV)
		1 min dry	10 s wet		1 min dry	10 s wet			
(kV)	mm/(in)	(kV)	(kV)	(1.2/50 μs)	(kV)	(kV)	(1.2/50 μs)	(kV)	(1.2/50 μs)
1.2	—	—	—	—	10	6	30	—	—
2.5	—	21	20	60	15	13	45	20	45
5.0	—	27	24	75	21	20	60	24	60
8.7	—	—	—	—	27	24	75	30	75
8.7	178/(7)	35	30	95	—	—	—	—	—
15.0	—	—	—	—	35	30	95	50 <sup>d</sup>	110 <sup>d</sup>
18.0	—	—	—	—	42	36	125	—	—
25.0	—	—	—	—	—	—	—	60	150
34.5	—	—	—	—	—	—	—	80	200

**Figure 5-2. Electrical Insulation Characteristics of Transformer Bushings**

**5.1.1.4 Capacitor banks**

There is one 600kVar fixed capacitor bank on feeder C73. This capacitor bank is planned to be replaced with a SCADA controlled capacitor bank. The new capacitor is expected to withstand temporary overvoltages associated with REFCL equipment operation.

**5.1.1.5 Insulators**

Based on the review and using SDG&E data, the insulator ratings were identified for porcelain insulators at 15kV and polymer insulators at 25kV. After a review of SDG&E standards and industry standards on insulators related to phase-to-ground and phase-to-phase voltage withstand capabilities, it was found that insulators on the SDG&E distribution system require no modification or replacement.

IEEE C2 NESC [10] recommends line insulators should have a rated dry flashover voltage following ANSI C29.1-1988 (R2012), and not less than the voltage levels shown in “Table 273-1” (Figure 5-3). Interpolation for intermediate value to 12kV reveals rated dry flashover voltage at 51.75kV and supports line insulators within the Descanso Substation conforming to ANSI C29.1 and Section 275 of [10]. This also shows that the insulators designed were selected for the rated full load voltage of the transformer. Additionally, Section 275 of [10], single-phase insulators directly connected to three-phase circuits without an



intervening isolation transformer should have a rated insulation level not less than the three-phase circuit connection.

**Table 273-1—Insulation level requirements**

Nominal voltage (between phases) (kV)	Rated dry flashover voltage of insulators <sup>①</sup> (kV)	Nominal voltage (between phases) (kV)	Rated dry flashover voltage of insulators <sup>①</sup> (kV)
0.75	5	115	315
2.4	20	138	390
6.9	39	161	445
13.2	55	230	640
23.0	75	345	830
34.5	100	500	965
46	125	765	1145
69	175		

① Interpolate for intermediate values.

Figure 5-3. Insulator Insulation Levels [10]

**5.1.1.6 Disconnect Switches**

After a review of SDG&E data, it was revealed that line and tie-line disconnect switches deployed on feeders C73, C78, and C79 were rated at a minimum voltage rating of 14.4kV. Following an additional review of IEEE standards, guides, and recommended practices on disconnect switches related to phase-to-ground and phase-to-phase voltage withstand capabilities, it was determined that disconnect switches on SDG&E distribution system require no modification or replacement.

**5.1.1.7 Cutouts**

An additional review of SDG&E data revealed that feeders C73, C78, and C79 have porcelain cutouts rated at 15kV and polymer cutouts rated at 27kV with CMU and SMU cutouts rated at 17kV and the S&C Fault Tamer rated at 25kV. Moreover, the review of IEEE standards, guides, and recommended practices, on cutouts related to phase-to-ground and phase-to-phase voltage withstand capabilities found that cutouts on the SDG&E distribution system require no modification or replacement.

**5.1.1.8 Reclosers**

SDG&E deploys three different vendors of reclosers on Feeders C73, C78, and C79. Of these three vendor reclosers, Thomas & Betts/MVR is the only recloser rated at the lesser voltage level of 15kV which according to Table 2, Note C, from [11] this voltage level “has historically been associated with metal-clad and metal-enclosed switchgear used for applications that are primarily indoors and/or outdoors where



the insulation level is less than that required for outdoor overhead applications.” Whereas the S&C/IRPC and Cooper/Form 6 reclosers are both rated at the preferred 15.5kV maximum voltage level for overhead distribution power systems. Therefore, the Thomas & Betts/MVR is an older recloser design that works for REFCL deployment, but SDG&E may want to review compliance with [11] for their future recloser deployments.

**Rated Maximum Voltage:** The rated maximum voltage indicates the upper limit of the highest voltage of the system for which reclosers are intended to operate. [11]

The values of the rated voltage of reclosers are those shown in column 2 of “Table 2” (Figure 5-4) for reclosers applied on overhead distribution systems and “Table 3” (Figure 5-5) for reclosers applied on cable-connected or padmount underground distribution systems.

Note C in “Table 2” (Figure 5-4) provides the ideal rating for North America electric utilities stating, “For applications other than metal-clad or metal-enclosed switchgear, the 15.5kV rating is preferred.”

**Table 2 – Rated maximum voltages and rated voltage withstand values for reclosers applied on overhead line distribution circuits<sup>a</sup>**

Line No.	Rated maximum voltage	Rated lightning impulse withstand voltage <sup>b</sup>	Rated short-duration power-frequency withstand voltage
	kV, r.m.s.	kV, peak	kV, r.m.s.
Col. 1	Col. 2	Col. 3	Col. 4
1	12	75	28
2	15 <sup>c</sup>	95	36
3	15,5	110	50
4	17,5	95	38
5	24	125	50
6	27	125	60
7	36	150	70
8	36	170	70
9	38	150	70
10	38	170	70

<sup>a</sup> The test values shown in Table 2 are for type tests; refer to 11.101 for field-testing.

<sup>b</sup> These performance characteristics specified as test requirements in this document.

<sup>c</sup> The 15 kV rating is used in North America and some other countries. It has historically been associated with metal-clad and metal-enclosed switchgear used for applications that are primarily indoors and/or outdoors where the insulation level is less than that required for outdoor overhead applications. For applications other than metal-clad or metal-enclosed switchgear, the 15,5 kV rating is preferred.

Figure 5-4. Overhead Recloser Ratings [11]



**Table 3 – Rated maximum voltages and rated voltage withstand values for reclosers applied on cable connected distribution circuits <sup>a</sup>**

Line No.	Rated maximum voltage	Rated lightning impulse withstand voltage	Rated short-duration power-frequency withstand voltage <sup>b</sup>	Related DC withstand test 15 min <sup>b,c,d</sup>
	kV, r.m.s.	kV, peak	kV, r.m.s.	kV
Col. 1	Col. 2	Col. 3	Col. 4	Col. 5
1	12	60	28	42
3	15,5	95	35	53
4	17,5	95	38	57
5	24	95	50	78
6	27	125	40	78
7	36	150	70	103
8	36	170	70	103
9	38	150	50	103
10	38	170	70	103

<sup>a</sup> The test values shown in Table 3 are for type tests; refer to 11.101 for field-testing.

<sup>b</sup> These are performance characteristics specified as test requirements in this document.

<sup>c</sup> DC withstand tests are required for pad-mounted, dry vault and submersible gear since this type of equipment is interfaced to the power system via separable connectors. The test requirements of separable connectors are specified IEEE Std 386 [6] and these values are reproduced here in column 5. The DC withstand test requirement on the recloser demonstrates its capability to withstand either DC withstand or the peak value of very low frequency (VLF) testing of connected cables.

<sup>d</sup> DC withstand testing of 36/38 kV cables is not a recommended practice. Very low frequency (VLF) testing is used as an alternative to the DC withstand test. Reference IEEE Std 400.2 [7].

Figure 5-5. Padmount Recloser Ratings [11]

**Rated Insulation Level:** The rated insulation level for reclosers applied to overhead distribution systems is identified in column 3 of “Table 2” (Figure 5-4). For 15kV the BIL is 95kV and 15.5kV the BIL is 110kV, where 15.5kV is the preferred equipment rating. Padmount reclosers applied on an underground cable connected distribution system, do not have a 15kV rating, only a 15.5kV rating with a BIL of 95kV.

**Rated Short-Duration Power Frequency Withstand Voltage:** According to “Table 2” (Figure 5-4) the “Rated short-duration power frequency withstand voltage” column identifies the maximum RMS value of the voltage that an overhead recloser connected to the distribution power system can withstand permanently.

For the SDG&E 12kV system voltage, for example, with reclosers rated at 15kV and 15.5kV, the rated power frequency withstands voltage, RMS value, kV for 1 minute, and is respectively 36kV and 50kV. These values define the maximum level of RMS overvoltage that the SDG&E reclosers may withstand for



1 minute. Therefore, in REFCL operation the recloser bushings on the SDG&E distribution power system will be capable of withstanding line-to-line voltages of 12kV.

This withstand voltage is what a new and clean recloser bushing is capable of withstanding for 1 minute, but if there are old and dirty recloser bushings on the SDG&E distribution power system then these reclosers may have to be tested to verify if it can withstand the rated frequency, and withstand voltage as shown in “Table 2” (Figure 5-4).

A listing of the reclosers used on feeders C73, C78, and C79 with vendor, model, assigned pole number, and maximum rated voltage are outlined below.

- Feeder C73
  - Thomas&Betts/MVR, 73-643R; 15kV
  - S&C/IRPC, 73-49R; 15.5kV
  - S&C/IRPC, 73-765R; 15.5kV
  - S&C/IRPC, 73-23R; 15.5kV
- Feeder C78
  - S&C/IRPC, 78-26R; 15.5kV
  - Cooper/Form 6, 78-404R; 15.5kV
- Feeder C79
  - S&C/IRPC, 79-679R; 15.5kV
  - S&C/IRPC, 79-676R; 15.5kV
  - S&C/IRPC, 79-673R; 15.5kV
  - S&C/IRPC, 79-658R; 15.5kV
  - S&C/IRPC, 79-685R; 15.5kV
  - S&C/IRPC, 79-660R; 15.5kV
  - S&C/IRPC, 79-668R; 15.5kV
  - Cooper/Form 6, 79-658R; 15.5kV
  - Cooper/Form 6, 79-799R; 15.5kV

Based on the review of [11], the reclosers used on the SDG&E overhead distribution power system have an adequate voltage rating for use with the Swedish Neutral REFCL ground fault network in the following application. When a phase-to-earth fault occurs on an ungrounded 3-phase distribution system, the phase voltage of the faulted phase is reduced to the ground potential. As the capacitance of the faulted line is discharged at the fault location, the phase-to-ground voltage of the other two phases rises by a  $\sqrt{3}$  times factor.

#### 5.1.1.9 Arresters

Based on a review of SDG&E standards and SDG&E data, the quantity of each arrester type requiring modification and/or replacement was identified. Power systems according to [12] is to be protected by distribution arresters and are either a three-wire wye or delta, high or low impedance grounded at the source or a four-wire multi-grounded wye. Proper application of metal-oxide surge arresters on





distribution systems requires knowledge of the maximum normal operating voltage of the power system and the magnitude and duration of TOV's during abnormal operating conditions.

The maximum continuous operating voltage (MCOV) is defined in [13] as the maximum designated root-mean-square (RMS) value of power-frequency voltage that may be applied continuously between the terminals of the arrester. Duty-cycle voltage rating and maximum system voltage are also defined in [13]. Maximum system voltage is generally considered to be the maximum system voltage as prescribed in ANSI Standard C84.1

Section 6.4.3 of [11], three-wire, high-impedance ground connected power systems suggests that an arrester MCOV rating should be equal, or exceed, the MCOV applied to the arrester. This implies that during a single line-to-ground fault, the worst-case line-to-line voltage seen from the faulted circuit is at 1.73pu line-to-ground voltage.

Since fault current values may be somewhat lower in a high impedance grounded system, protective relaying schemes may allow this type of fault to exist for a considerable amount of time. An arrester should have the capability to withstand line-to-line voltage for the maximum time required by the protection scheme to clear the fault. General practice is to choose an arrester with an MCOV rating greater than the maximum system line-to-line voltage.

According to [14] there are service conditions, and certain standards a surge arrester must conform to and successfully operate under various system service conditions. The identified various system service conditions are listed in Figure 5-6.

System line-to-line voltages (kV rms)		Recommended arrester ratings (MCOV) kV rms		
Nominal	Assumed maximum	Four-wire wye multi-grounded neutral	Three-wire or four-wire wye solidly grounded neutral @ source	Delta and ungrounded wye
12.0	12.6	9 (7.65)	9 (7.65) or 10 (8.40)	12 (10.2) or 15 (12.7)
12.47	13.1	9 (7.65)	9 (7.65) or 10 (8.40)	15 (12.7) or 18 (15.3)

Figure 5-6. "Table 2" (Figure 5-4) Arrester Rating Selection

Existing SDG&E arresters on the distribution power system are rated 10kV with MCOV 8.4kV. Arresters on feeders C73, C78, and C79 may require replacement to either the 12kV (10.2kV) or 15kV (12.7kV) arresters due to an anticipated rise in line-to-line voltage levels on un-faulted phases as noted in "Table 8" (Figure 5-7) [12].



**Table 8—Commonly applied voltage ratings of metal-oxide arresters on distribution systems**

System RMS voltage (V)		Commonly applied arrester duty-cycle (MCOV) voltage rating (kV) on distribution systems		
Nominal voltage	Maximum voltage range B	Four-wire multigrounded neutral wye	Three-wire low impedance grounded	Three-wire high impedance grounded
2400	2540			3 (2.55)
4160Y/2400	4400Y/2540	3 (2.55)	6 (5.1)	6 (5.1)
4160	4400			6 (5.1)
4800	5080			6 (5.1)
6900	7260			9 (7.65)
8320Y/4800	8800Y/5080	6 (5.1)	9 (7.65)	
12 000Y/6930	12 700Y/7330	9 (7.65)	12 (10.2)	
12 470Y/7200	13 200Y/7620	9 (7.65) or 10 (8.4)	15 (12.7)	
13 200Y/7620	13 970Y/8070	10 (8.4)	15 (12.7)	
13 800Y/7970	14 520Y/8380	10 (8.4) and 12 (10.2)	15 (12.7)	
13 800	14 520			18 (15.3)
20 780Y/12 000	22 000Y/12 700	15 (12.7)	21 (17.0)	
22 860Y/13 200	24 200Y/13 970	18 (15.3)	24 (19.5)	
23 000	24 340			30 (24.4)
24 940Y/14 400	26 400Y/15 240	18 (15.3)	27 (22.0)	
27 600Y/15 935	29 255Y/16 890	21 (17.0)	30 (24.4)	
34 500Y/19 920	36 510Y/21 080	27 (22.0)	36 (29.0)	

Figure 5-7. “Table 8” [12]

SDG&E has installed arresters on their distribution network according to 12,000Y/6,930 nominal voltage and column ‘Three-wire low impedance grounded’ with a 10kV (8.4kV MCOV) rating. This application conforms with [12] and protects with the lowest-rated surge arrester. It maintains adequate overall protection of the equipment insulation and has a satisfactory service life while connected to the distribution power system.

However, with the introduction of the Swedish Neutral ground fault network the distribution power system will change from a low impedance grounded system to a high impedance grounded system. High resistance and low resistance power systems are considered ungrounded for the selection of the appropriate surge arrester. Within a line-to-ground fault, the un-faulted phases and their respective arresters may experience line-to-line maximum voltage levels.

[12] “Table 8” (Figure 5-7), column ‘Three-wire high impedance grounded’ above, has blank cell arresters for these voltage levels and requires an MCOV equivalent to at least 100% of the maximum operating voltage on the distribution power system. Testing may be necessary to validate whether the present design 10kV (8.4kV MCOV) arresters on Feeders C73, C78, and C79 can be replaced with 12kV (10.2kV) or 15kV (12.7kV) arresters.

Based on the results above and the SDG&E data the following quantity of each equipment type based on the feeder circuit that requires modification and/or replacement was identified. Discussions with SDG&E revealed that type HJ transformers have 10kV MCOV 8.4kV surge arresters attached to the transformer



case and are difficult to replace. Due to this surge arrester configuration 605 single-phase 25kVA and 23 single-phase 50kVA HJ transformers require replacement.

Feeder C73:

- 60: 2-Phase Cable Pole Surge Arresters
- 66: 3-Phase Cable Pole Surge Arresters
- 9: Capacitor Bank Surge Arresters
- 24: Recloser Surge Arresters
- 464: 1-Phase OH Transformer Surge Arresters
- 78: 3-Phase OH Transformer Surge Arresters
- 306: 1-Phase 25kVA OH HJ Transformers
- 12: 1-Phase 50kVA OH HJ Transformers

Feeder C78:

- 60: 2-Phase Cable Pole Surge Arresters
- 27: 3-Phase Cable Pole Surge Arresters
- 6: Recloser Surge Arresters
- 9: Voltage Regulator Surge Arresters
- 153: 1-Phase OH Transformer Surge Arresters
- 21: 3-Phase OH Transformer Surge Arresters
- 63: 1-Phase 25kVA OH HJ Transformers
- 2: 1-Phase 50kVA OH HJ Transformers

Feeder C79:

- 152: 2-Phase Cable Pole Surge Arresters
- 66: 3-Phase Cable Pole Surge Arresters
- 54: Recloser Surge Arresters
- 9: Voltage Regulator Surge Arresters
- 646: 1-Phase OH Transformer Surge Arresters
- 111: 3-Phase OH Transformer Surge Arresters
- 236: 1-Phase 25kVA OH HJ Transformers
- 9: 1-Phase 50kVA OH HJ Transformers

## 5.2 Estimated Costs for Overhead System Upgrades

Table 5-1 provides a list of each item, quantity, and cost for the overhead system upgrades necessary for the feeder distribution circuits to operate properly whenever the Swedish Neutral REFCL equipment is energized during high-risk fire season. The total for these overhead system upgrades amounts to \$7,187,111 for the Overhead Transformer cost and \$4,173,149 for the Surge Arrester cost that includes labor and materials, and removal of the existing transformers and overhead surge arresters and terminations.



**Table 5-1. Estimated Costs for Overhead System Upgrades (includes 30% Contingency)**

Circuit   Rating	Units Replaced	Item	Cost
C73	701	Surge Arrester	\$1,588,153
C78	276	Surge Arrester	\$625,293
C79	865	Surge Arrester	\$1,959,703
<b>Surge Arrester Upgrade Total</b>			<b>\$4,173,149</b>
25kVA	605	OH Transformer	\$6,905,925
50kVA	23	OH Transformer	\$281,186
<b>OH Transformer Upgrade Total</b>			<b>\$7,187,111</b>

### 5.3 Underground System Equipment

Underground system equipment is best suited to withstand a variety of climatic disturbances more so than overhead system equipment, but the electrical properties of underground cables are quite different from overhead conductors. Shunt capacitance is higher while series inductance is smaller than overhead conductors. This capacitance can be effectively compensated as previously described in Section 4 in conjunction with Sections 2 and 3 describing installation and protection coordination with new Swedish Neutral REFCL equipment. Any ground-fault current that is not compensated is residual current that the REFCL equipment may detect. This detection can be visualized during normal operating conditions on a three-phase distribution system where loading and line impedances in all three phases are relatively equal and symmetrical. When a ground fault occurs, this will cause the faulted phase voltage to decrease as current increases and the un-faulted phase(s) will increase nearly to the level of a symmetrically balanced line-to-line voltage. The following evaluations of underground equipment are to verify that this equipment can withstand the level of a symmetrically balanced line-to-line voltage.

The comparison of the equipment and ratings provide an initial assessment. High voltage testing of sample equipment can help confirm whether the equipment can withstand the overvoltages or requires replacement.

#### 5.3.1 3-Phase and 2-Phase Underground System Equipment

Three-phase and two-phase underground systems were reviewed in parallel to the overhead systems. It was inclusive of an assessment review of the distribution of underground cables. The assigned task was to ascertain if any underground systems that use a neutral conductor for phase-to-neutral connected load should be converted to a phase-to-phase system.

- SDG&E currently installs underground 15kV rated distribution cables with concentric neutral.
- Any 15kV rated distribution cables installed without a concentric neutral still in operation would be an exception due to age and older standards not currently utilized.
- Information from Swedish Neutral was obtained during discovery and found that two-phase and three-phase primary underground 15kV conductors with concentric neutral may remain in service



during REFCL operation without interfering with the REFCL algorithm in the REFCL controller and monitoring unit.

- However, our assessment on the 15kV underground cables revealed that the insulation levels and voltage ratings are needed for further analysis.

### 5.3.2 Medium Voltage Underground Cables

The SDG&E underground cable voltage ratings are #2AWG AL and 2/0 AWG AL while the extruded connectors have a voltage rating of 15kV. The SDG&E stock numbers for each underground cable type (one-conductor, two-conductor, and three-conductor) for conductor sizes #2AL and 2/0 are listed below:

- Stock # 197600 – 1/C # 2 AL
- Stock # 197602 – 2/C # 2 AL – this is a parallel configuration – cables are not wrapped together
- Stock # 197622 – 3/C # 2 AL – the cables are in a triplex configuration
- Stock # 197606 – 3/C 2/0 AL – the cables are in a triplex configuration

The primary focus of the 3-phase and 2-phase underground cables installed by SDG&E determined that the jacketed underground distribution cables, installed in conduit, could not withstand a 12kV line-to-ground overvoltage when the Swedish Neutral REFCL equipment was energized.

According to [2] the selection of the cable insulation (voltage) rating is made based on the phase-to-phase voltage of the system the cable is applied, whether the system is grounded or ungrounded, and the time in which a ground fault on the system is cleared by protective equipment. It is possible to operate cables on ungrounded systems for long periods with one phase grounded due to a fault. This results in line-to-line voltage stress across the insulation of the two ungrounded conductors. Therefore, a cable must have a greater insulation thickness than a cable used on a grounded system. Note that it is impossible to impose full line-to-line potential on the other two un-faulted phases for an extended period.

[2] further defines the insulation level for cables classified by 100%, 133%, and 173%.

100% insulation level cables apply to a grounded system where the protection devices will clear any ground faults within 1 minute. On an ungrounded system where clearing time is in the 100% level category cannot be met and there is adequate assurance that the faulted section will be cleared within 1 hour 133% insulation level cables are used. On grounded or ungrounded systems where the time required to de-energize a grounded section is indefinite, a 173% insulation level is used.

Correspondingly, [3] provides a definition for the cable voltage rating: “The voltage rating of a cable is based, in part, on the thickness of the insulation and the type of the electrical system to which it is connected. General system categories are as defined by the Association of Edison Illuminating Companies (AEIC).”

[3] and [4] also define the insulation level for cables classified by 100%, 133%, and 173%, by providing additional applications and recommendations for each cable type.

Table 5-2 below from [5] provides cable insulation levels and voltage ratings based on various expected voltages for multiple insulation levels as previously defined by [2], [3], and [4].



Table 5-2. Cable Insulation Levels

Cable Rate Voltage L-L kV	100% Insulation Level L-G kV	133% Insulation Level L-G kV	173% Insulation Level L-G kV
5	2.4	3.2	4.16
8	4.6	6.2	8.0
15	8.7	12.0	15.0
25	15.0	19.0	25.0
35	20.0	27.0	35.0
46	27.0	35.0	46.0

Based on the previously stated information ([2], [3], [4], and [5]) it appears that SDG&E may have to replace its 100% insulated underground cables with a minimum of 133% insulation cables to operate with the Swedish Neutral REFCL system.

### 5.3.3 Medium Voltage Cable Terminations Rated 2.5kV to 46kV

Discussions with SDG&E revealed that [6] is referenced when choosing cable terminations for overhead and underground equipment. Extruded cable terminations have been used on numerous occasions, which is outlined in “Table 1” (Figure 5-8) from [6]. Laminated cable terminations are shown in “Table 3” (Figure 5-9 and Figure 5-10) from [6] and were installed up until the 1960s for underground copper cables.



**Table 1—Standard dielectric test values for medium-voltage extruded dielectric cable terminations rated 2.5 kV to 46 kV**

Insulation class (kV) (NOTE 12)	Nominal voltage-to-ground (kV rms) (NOTE 13)	Minimum partial discharge voltage level (kV rms) (NOTE 11)	AC voltage 1 min dry withstand (kV rms)	AC voltage 10 s wet withstand (kV rms) (NOTE 3)	Lightning impulse (BIL) voltage withstand (kV crest) (NOTE 4)	Cyclic aging (kV rms)	AC voltage 5 min withstand (kV rms)	AC voltage 5 h dry withstand (kV rms)	AC voltage 1 min dry withstand (terminations and joints) (kV rms)	DC voltage 15 min dry withstand (kV avg) (NOTE 9)	Wet (dry) switching impulse (BSL) voltage withstand (kV crest) (NOTES 3 & 4)
Column 1	Column 2	Column 3	Column 4	Column 5	Column 6	Column 7	Column 8	Column 9	Column 10	Column 11	Column 12
2.5	1.4	2	20	20	60	4	6	5	9	30	NA
5	2.9	5	25	25	75	9	13	10	18	35	NA
8	4.6	7	35	30	95	14	21	16	23	45	NA
15	8.7	13	50	45	110	26	39	31	35	75	NA
25	14.4	22	65	60	150	43	65	50	52	105	NA
35	20.2	30	90	80	200	61	91	71	69	140	NA
46	26.6	40	120	100	250	67	100	80	80	172	NA

NOTE 1—Power frequency includes any frequency from 48 Hz to 62 Hz.  
 NOTE 2—All withstand values are test voltages without negative tolerance but may include an atmospheric correction factor.  
 NOTE 3—Indoor cable terminations are not subjected to the ac voltage 10 s wet withstand test and the wet (dry) switching impulse (BSL) voltage withstand test. Indoor cable terminations shall be tested at three times phase-to-ground voltage.  
 NOTE 4—The required lightning and switching impulse values shall be met with both positive and negative polarity tests.  
 NOTE 5—On assembled multiple conductor cable terminations, the tests shall be made between each conductor and ground with the terminals on adjacent conductors grounded.  
 NOTE 6—The values in this table are for general use. It is recognized that cable terminations of higher or lower insulation class or BIL may be used where conditions warrant and when specified and agreed upon.  
 NOTE 7—When the dielectric strength of the cable termination is dependent upon taping or the use of auxiliary insulation, such insulation shall be used for any design tests.  
 NOTE 8—When a termination is assembled with cable for its dielectric test in the equipment or in the apparatus in which it will operate, the applied test voltage shall be determined by the tests required for the equipment or apparatus if these voltages are lower than the values listed in the table.  
 NOTE 9—The dc voltage 15 min dry withstand test shall be made with negative polarity on the conductor. Refer to 7.3 of this standard for comments regarding the direct voltage field test values.  
 NOTE 10— Certain types of resistance or capacitance graded cable terminations are sensitive to prolonged overvoltage testing and may not be able to withstand some of the power frequency and direct voltage tests, although they are perfectly satisfactory for service. In such cases, the manufacturer shall so specify and shall perform such other special tests as agreed upon by the user.  
 NOTE 11— The minimum detector sensitivity shall be 5.0 pC.  
 NOTE 12— For use with 100% insulation level. Use cables with the thinnest insulation as defined in AEIC CS8-07 [B5]. To obtain test values for voltage classes that are not listed, use linear interpolation between the two closest listed values and round off to the nearest whole kilovolt.  
 NOTE 13— For grounded systems.

**Figure 5-8. Extruded Dielectric Cable Terminations**



**Table 3—Standard dielectric tests for high-voltage laminated dielectric cable terminations assembled and ready for service**

Insulation class (kV) (NOTE 11)	Nominal voltage-to-ground (kV rms) (NOTE 12)	AC voltage 1 min dry withstand (kV rms)	AC voltage 10 s wet withstand (kV rms) (NOTE 3)	AC voltage 6 h dry withstand (kV rms)	Cyclic aging (kV rms)	Radio influence voltage (RIV) (µV)	Ionization factor (all voltage classes) (%)	Lightning impulse (BIL) voltage withstand (kV crest)	Wet (dry) switching impulse (BSL) voltage withstand (kV crest) (NOTE 3)	DC voltage 15 min dry withstand (kV avg) (NOTE 9)
Column 1	Column 2	Column 3	Column 4	Column 5	Column 6	Column 7	Column 8	Column 9	Column 10	Column 11
2.5	1.4	20	20	10	3	50	See Table 6, Table 8, and 8.4.1.9.	60		30
5	2.9	25	25	15	6	50		75		38
8.7	5.0	35	30	25	10	50		95		48
15	8.7	50	45	35	17	50		110		55
25	14.4	65	60	55	29	100		150		75
35	20.2	90	80	75	40	150		200		100
46	26.6	120	100	100	53	200		250		125
69	39.8	175	145	120	80	300		350		175
92.5	53.4	205	190	160	133	400		450		225
115	66.4	230	230	190	140	450		550		275
138	79.7	310	275	210	160	500		650		325
161	93.0	365	315	250	186	500		750		375
230	132.8	390	380	320	265	500		900		450
230	132.8	460	445	320	265	500		1050		525
345	199.2	520		440	300	500		1175	(900)	588
345	199.2	575		440	300	500		1300	825	650
345	199.2	575		440	300	500		1300	900	650
500	288.7	575		440	435	500		1300	(1100)	650
500	288.7	690		440	435	500		1550	1050	775
500	288.7	750		575	435	500		1675	1110	838
500	288.7	750		575	435	500		1675	1175	838
765	441.7	1300		755	663	500	2075	1435	1038	
765	441.7	1300		755	663	500	2175	1505	1038	

**Figure 5-9. Laminated Dielectric Cable Terminations (1 of 2)**





**Table 3—Standard dielectric tests for high-voltage laminated dielectric cable terminations assembled and ready for service (continued)**

<p>NOTE 1—Power frequency includes any frequency from 48 Hz to 62 Hz.</p> <p>NOTE 2—All withstand values are test voltages without negative tolerance but may include an atmospheric correction factor.</p> <p>NOTE 3—Indoor cable terminations are not subjected to the ac voltage 10 s ac and BSL wet tests. Indoor terminations, 230 kV and less, to be tested at three times phase-to-ground voltage. Indoor terminations rated 345 kV and higher shall withstand dry switching impulse voltage (column 10). Outdoor terminations rated 345 kV and higher shall withstand wet switching impulse voltage (column 10). The BSL voltage test for outdoor terminations 345 kV and higher are performed in lieu of 10s ac voltage withstand test.</p> <p>NOTE 4—The required lightning and switching impulse values shall be met with both positive and negative polarity tests.</p> <p>NOTE 5—On assembled multiple conductor cable terminations, the tests shall be made between each conductor and ground with the terminals on adjacent conductors grounded.</p> <p>NOTE 6—The values in this table are for general use. It is recognized that cable terminations of higher or lower insulation class or BIL may be used where conditions warrant and when specified and agreed upon.</p> <p>NOTE 7—When the dielectric strength of the cable termination is dependent upon taping or the use of auxiliary insulation, such insulation shall be used for any design tests.</p> <p>NOTE 8—When a cable termination is assembled with cable for its dielectric test in the equipment or in the apparatus in which it will operate, the applied test voltage shall be determined by the tests required for the equipment or apparatus if these voltages are lower than the values listed in the table.</p> <p>NOTE 9—The dc voltage 15 min dry withstand test shall be made with negative polarity on the conductor. Refer to 7.3 of this standard for comments regarding the direct voltage test values.</p> <p>NOTE 10—Certain types of resistance or capacitance graded cable terminations are sensitive to prolonged overvoltage testing and may not be able to withstand some of the power frequency and direct voltage tests, although they are perfectly satisfactory for service. In such cases, the manufacturer shall so specify and shall perform such other special tests as agreed upon by the user.</p> <p>NOTE 11—For use with 100% insulation cable as defined in AEIC CS1-90 [B1]. To obtain test values for voltage classes that are not listed, use linear interpolation between the two closest listed values and round off to the nearest whole kilovolt.</p> <p>NOTE 12—For grounded systems.</p>
---

**Figure 5-10. Laminated Dielectric Cable Terminations (2 of 2)**

As previously noted, the voltage ratings on medium voltage cables are defined by insulation levels. SDG&E uses 100% insulation levels for its underground cable along with cable terminations as described in [6].

Based on the previously stated information from SDG&E and IEEE it seems that SDG&E may have to replace their 15kV rated extruded terminations with 25kV voltage rated terminations. By installing 25kV rated terminations, these terminations will be able to withstand 14.4kV line-to-ground voltages, a 20% more voltage level than the normal operating 12kV system voltage during operation with the Swedish Neutral REFCL system.

### 5.4 Estimated Costs for Underground System Upgrades

Table 5-3 provides a list of each item, quantity, and cost for the underground system upgrades necessary for the feeder distribution circuits to operate properly whenever the Swedish Neutral REFCL equipment is energized during high-risk fire season. The total for these underground distribution system upgrades amounts to \$10,742,922 and includes labor, material, and removal of the existing underground padmount transformers, cables and terminations.



**Table 5-3. Estimated Costs for Underground System Upgrades (includes 30% Contingency)**

Item Description	Units Replaced	Item	Cost
12kV Underground System Upgrades	See Table A-7*	Underground Cables & Terminations	\$10,582,682
25kVA Padmount Transformer	11	C78 Padmount Transformer	\$146,912
50kVA Padmount Transformer	1	C73 Padmount Transformer	\$13,328

\* in Appendix A of this document

## 5.5 Primary System Customers

After a review of feeders C73, C78, and C79 and using SDG&E company data, it was revealed that there were no primary system customers on these circuits connected via overhead or underground.



## 6 REFCL OPERATIONS OPTIONS AND IMPACTS

The REFCL activation periods may be based on the Fire Potential Index (FPI) used by SDG&E, with the highest risk set at Extreme. Additional REFCL activation options exist and are provided below.

The implementation of REFCL will bring new operational challenges and requirements to SDG&E. Additionally, the restoration process will have restrictions due to capacitance balancing, which is further discussed below.

### 6.1 Option 1: REFCL Activated During Extreme FPI

Circuit breakers' and field reclosers' automatic reclosing is disabled year-round for the Descanso circuits. If a circuit or field recloser trips open, re-energizing can only occur after a strong belief that there is no longer a fault, either due to patrolling, repairs, or other confirmed information.

When the GFN protection system detects a line-to-ground fault, the entire circuit will be de-energized. The GFN protection system detects the circuit with the line-to-ground fault and without intentional delay, would signal for that circuit's breaker to open. The field reclosers are unable to detect the downstream line-to-ground fault within the GFN parameters and will not operate. As a result, more customers may have an outage for line-to-ground faults downstream of reclosers. New technology is under consideration in Australia that would potentially detect beyond where the recloser line-to-ground fault occurred. This needs further evaluation and testing to confirm success.

For phase to phase faults, the protection system within the substation and beyond field reclosers will operate normally without being impacted by the REFCL activation.

Capacitance balancing for each circuit must be routinely maintained, otherwise the GFN system may operate and result in de-energizing the circuit. Switching operations must also be within the parameters that maintain balancing at the feeder head. This means that the isolation of the faulted section may be required per balanced sections, which also means that switches in between reclosers could not be operated or they may cause an imbalance. Also, the Descanso circuits are unable to restore load from other substations' circuits which may result in a possible unbalance. The Descanso circuits could be restored via ties from other substations, although parallels between the substations cannot occur.

### 6.2 Option 2: REFCL Activated with Different Settings

REFCL would still be activated with the same protection system impacts like those of high fire risk periods. Following line-to-ground fault detection, the entire faulted circuit would still be de-energized automatically, not allowing downstream reclosers to automatically detect and sectionalize. Additional options exist if the FPI is not extreme. For example, to determine the faulted section beyond reclosers, remote fault testing is an option depending on SDG&E practices. Capacitance balancing would still be required.



### 6.3 Option 3- REFCL Not Activated

REFCL can be fully disabled while utilizing conventional protection systems and operations practices. Circuit breakers’ and field reclosers’ automatic reclosing could be enabled in normal mode based on SDG&E practices. Sensitive ground fault settings could be enabled, and circuit ties between different substations could be used based on normal practices. In this operational mode, the substation transformer 12kV neutral would again be directly grounded per SDG&E standards. The substation transformer midpoint wye would be reconnected directly to the ground grid via an installed single-phase recloser.

### 6.4 REFCL Activation Substation Grounding

Section 2.2 provides the Swedish Neutral GFN implementation options. The main difference being that option 1 uses a grounding transformer provided in the GFN container. Option 2 uses the existing substation’s grounding transformer. Table 6-1 provides the substation bank grounding requirements for the multiple operations options. As indicated, there is no operational difference between the two options.

Table 6-1. REFCL Activation Substation Bank Grounding Requirements

REFCL Activation Options	Substation Layout Option 1	Substation Layout Option 2
Option 1- Activated: High FPI	GFN Activated, Substation Bank Wye Neutral Disconnected from Ground Grid	GFN Activated, Substation Bank Wye Neutral Disconnected from Ground Grid
Option 2- Activated: Lower FPI	GFN Activated, Substation Bank Wye Neutral Disconnected from Ground Grid	GFN Activated, Substation Bank Wye Neutral Disconnected from Ground Grid
Option 3- Deactivated	Substation Bank Wye Neutral Connected to Ground Grid by Closing Recloser	Substation Bank Wye Neutral Connected to Ground Grid by Closing Recloser



## 7 REFCL BENEFITS AND EVALUATION

### 7.1 Earth Fault Current Management

Earth fault current management is a topic of interest when it comes to REFCL operation. The driving principle of REFCL technology is to reduce the earth fault current to virtually zero to reduce risks of potential fire ignition.

There are operational challenges associated with the REFCL technology which may make increasing the earth fault current desirable under certain scenarios. The main challenges are due to the P&C fundamentals paradigm shift transitioning from current to voltage-based relaying and new types of sensitive fault detection algorithms (Admittance, Harmonics, etc.).

One of the first core challenges with a REFCL grounded system is fault detection itself. The lack of practical experiences and level of confidence with those novel ground relaying algorithms and relays are a reality that utilities migrating towards REFCL technology have to deal with. Ground relaying redundancy could also prove to be a challenge, at least short term until more proven technologies are available from utility approved relay manufacturers. As an example, utilities located in the state of Victoria, Australia are currently using REFCL solution manufacturer, IED, as a primary ground relay and the secondary ground protection scheme is relying on existing substation equipment (i.e. bus VTs and IEDs) to measure the neutral voltage measurement at the local bus. This secondary relaying scheme, upon earth fault detection, decides to ground the distribution network through the local transformer grounding resistance and thus, allowing conventional ground relaying to detect the fault and operate. This secondary relaying approach is assumed to be temporary until the relay manufacturers approved by this Australian utility come up with robust and well-tested fault detection algorithms that can be retrofitted in their existing feeder IEDs.

Even with qualifying redundant protection relaying, fault location processing could still prove to be more challenging than with conventional effectively grounded distribution systems. The selectivity of the distribution protection schemes when operating with REFCL is a criterion that will require thorough evaluation under multiple operating conditions, and therefore might not be considered as reliable as conventional ground relaying, at least, during pilot station projects and the early deployment stage. Allowing to “test” the earth’s fault by bringing back the system normal grounding mode and reclosing the tripped breakers can be done to facilitate fault location through conventional ground relaying algorithms.

Switching the system grounding from the Petersen Coil to effectively grounded is defeating the main purposes of REFCL technology, that being fault suppression. It is still important to highlight that this possibility does exist, and under which circumstances it has been done elsewhere. Overall, this is not an ideal practice, especially during Red Flag season, as the risk of ignition significantly increases as fault current rises.

It is understood that this practice is currently utilized as a temporary measure until REFCL and associated protection relaying technologies mature enough so that complete and reliable faults detection and identification solutions are deemed compliant with the utility’s standard practices.



## 7.2 Comparison with SDG&E Current Practices

SDG&E already uses different technologies and means to reduce the risk of fire ignition following an earth fault. These techniques are utilized during the Red Flag period and also during normal operation when ignition risk is lower. These technologies and practices all have their pros and cons all of which will be evaluated in this section.

The existing SDG&E ignition mitigation techniques to be contrasted with REFCL technology in this section include the following: Ground Relaying Philosophy (SGF and Profile 3), Distribution Falling Conductor Protection (DFCP), and Public Safety Power Shutoff (PSPS). Reclosing practice will also be discussed as part of this evaluation.

### 7.2.1 SDG&E Ground Relaying Philosophy

SDG&E has a wide array of ground relaying strategies and algorithms deployed during normal and Red Flag operating conditions.

The main line of defense against high impedance and intermittent ground faults are currently the following:

- Profile 3 Settings (Sensitive profile)
- Sensitive Ground Fault protection (SGF)
- IED manufacturers proprietary algorithms (Spike counting, adaptive setpoints, etc.)

#### 7.2.1.1 Profile 3 Settings

A Profile 3 settings group can be enabled remotely through SCADA and is made of a more sensitive flat delay phase and ground element. This profile is enabled on an as-needed basis built on meteorological forecasting from SDG&E's meteorologist. As of today, the Profile 3 setting group is only deployed on reclosers. Substation distribution feeder relays are not equipped with this profile due to the high volume of electromechanical relays still in service.

In terms of settings, the pickup of these elements is typically set at 120% of the peak one-year historical standing neutral current or load current for the ground and phase characteristics respectively. The typical flat delay of these elements is 1 cycle. Reclosing is automatically disabled with the enabling of the Profile 3 settings group.

When deployed, fault selectivity along the feeder will be compromised, but better sensitivity will be achieved which in concept reduces the risk of ignition. Fault location accuracy should be adequate as it will rely on existing well-known algorithms and principles.

The main limitation of this element from a fire ignition prevention perspective is the sensitivity of the element being restricted by the system parameters (phase balancing and peak loading) which will ultimately limit the usefulness of Profile 3 relaying elements for higher impedance faults ( $I < 5A$ ).

Table 7-1 presents the key benefits and limitations for SDG&E Profile 3 relaying practice.



Table 7-1. Key Benefits and Limitations of SDG&E Profile 3 Relaying Practice

Benefits	Limitations
<b>Intuitive:</b> Rely on well-understood protection engineering principles.	<b>Sensitivity:</b> Limited by historical system parameters: <u>Ground element:</u> Standing load unbalance. <u>Phase element:</u> Peak load.
<b>Availability:</b> Required equipment/technology already mostly deployed on reclosers and feeder IEDs.	<b>Coordination/Selectivity:</b> Compromised for feeder relaying. Risk of larger customer outages.
<b>Fast:</b> 1 cycle intentional flat delay + interrupting device opening time.	<b>Ignition:</b> Risks not completely mitigated.
<b>Ignition:</b> Risks will be reduced for earth faults.	

### 7.2.1.2 Sensitive Ground Fault (SGF) Settings

Sensitive Ground Fault (SGF) elements rely on similar principles as Profile 3 ground overcurrent in the sense that it is a flat delay element and that its sensitivity limitation will come from the protected circuit historical peak standing neutral current. Similar to Profile 3 group settings, it is only enabled in recloser IEDs, can be enabled or disabled remotely through SCADA, and will drive reclosing to lockout following a trip condition.

The main differences with Profile 3 ground elements are the SGF longer operating time and the coordination margin retention between reclosers which allows SGF to remain enabled outside of Red Flag condition and still maintain proper selectivity and reduced outage sizes.

Typical SDG&E pickup settings for this element is in the range of 5 to 90A primary and it has a flat time delay of a minimum of 3 seconds for the device located the furthest away from the substation. The time delay is increased by an increment of 0.5 seconds for each device located upstream to allow for proper scheme coordination.

This methodology has a few limitations when it comes to mitigating ignition risks. To maintain scheme security, the pickup of this element will be maintained in a range where sensitivity may not be sufficient to cover a very high impedance ground fault scenario that could potentially cause ignitions. Another disadvantage of this technique is the longer operating time which falls in a time range that is long enough to cause ignition. Long feeders with several reclosers along their length require multiple steps of IED-to-IED grading of SGF time settings. The longer time delay also reduces the capacity of detecting intermittent ground faults.

Table 7-2 presents the key benefits and limitations for SDG&E SGF relaying practice.



Table 7-2. Key Benefits and Limitations of SDG&E SGF Relaying Practice

Benefits	Limitations
<b>Intuitive:</b> Rely on well-understood protection engineering principles.	<b>Sensitivity:</b> Limited by historical system parameters: <u>Ground element:</u> Standing load unbalance. Typical SDG&E settings in 5 to 90A range.
<b>Availability:</b> Required equipment/technology already mostly deployed on reclosers and feeder IEDs.	<b>Speed:</b> Minimum operating time is 3 seconds. Intermittent ground fault detection is challenging to detect.
<b>Coordination/Selectivity:</b> Maintained for feeder relaying. Smaller customer outages.	<b>Ignition:</b> Risks not completely mitigated.
<b>Ignition:</b> Risks will be reduced for earth faults.	

### 7.2.1.3 IEDs Manufacturer Proprietary Algorithms

Over the recent years, IED manufacturers have started to pay greater attention to distribution system high impedance fault detection challenges. Many of these manufacturers have come up with proprietary algorithms relying on different principles such as spike counting and earth current trend adaptive pickup. These algorithms rely mainly on filtered AC signals, but some manufacturers offer protection elements based on unfiltered AC signals (raw).

Based on the *SPS-2101 SDG&E Distribution Settings Methodology* document provided by SDG&E, there are currently 3 IEDs with enhanced HIF functionalities used on SDG&E’s distribution network:

- S&C IntelliRupter (Spike counting)
- Cooper Form 6 (Spike counting and adaptive ground pickup)
- SEL-651R (Spike counting and the sum of difference current)

These different algorithms do offer benefits over the ubiquitous conventional ground relaying elements based on static pickup and a combination of time delays (IOC, TOC, or DTOC).

With the right sensitivity, the spike counting elements do offer the advantage of tracking intermittent faults efficiently and will allow the detection of a ground fault based on a combination of spikes counted and frequency over a moving time window. This represents an appreciable gain in high impedance fault (HIF) detection scheme capability. A gain in sensitivity can also be attained using adaptive ground pickup elements such as the one programmed in Cooper Form 6 relays. The main benefit of this element is that rather than being static and based on the 1-year peak circuit unbalance, this element is dynamically changing its pickup following the last-minute on-line circuit unbalance continuously recorded in the IED buffer. The sensitivity improvement compared to conventional static ground overcurrent (i.e. Profile 3 and SGF) increases as the circuit load shrinks and the standing unbalance becomes less prominent.

These proprietary manufacturer ground relaying elements do constitute an advancement in the detection of high impedance faults but are still coming with their share of challenges and shortcomings. Since its initial deployment, SDG&E has experienced spurious tripping events caused by the spike counting





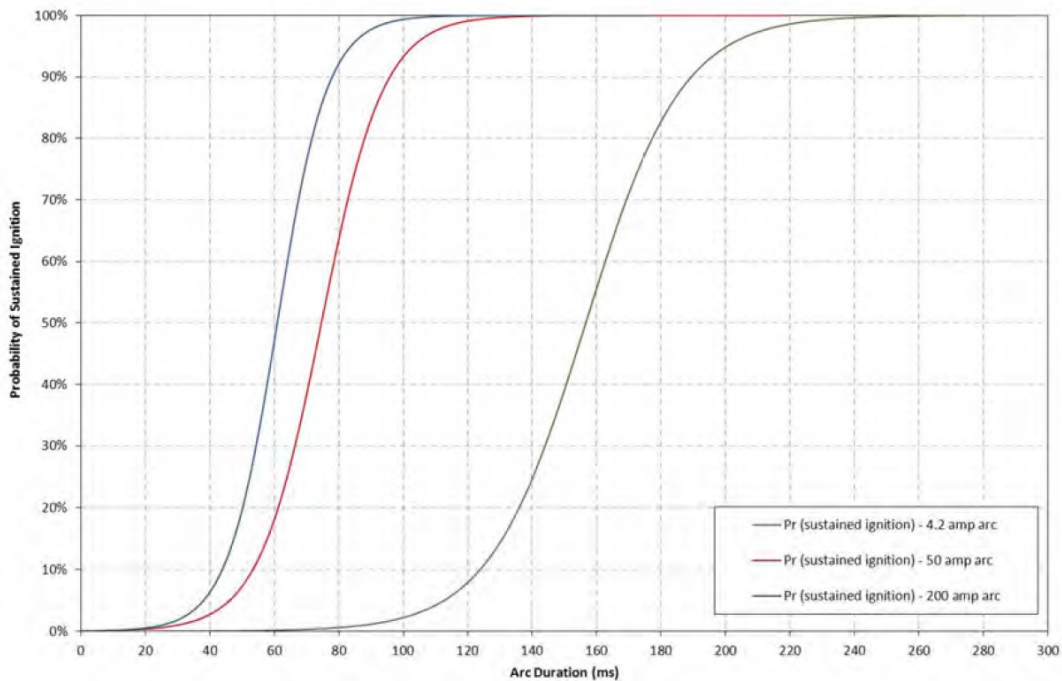
function, especially when unfiltered (raw) data is used for the protection algorithm processing. SDG&E is currently disabling the raw signals spike counting algorithm on Cooper Form 6 devices to ensure scheme security.

In terms of ignition deterrence, the two main limitations from these advanced ground protection algorithms lie in the fact that the sensitivity and speed of operation are still not to a level where fire ignition mitigation can be confirmed with a high degree of confidence, especially considering that with the “right” meteorological conditions, ignition can occur for current well below 5 A, even if sustained for a very short time, i.e. 500 ms or less.

Figure 7-1, *Probability of Bushfire Ignition from Electric Arc Faults*, is from a technical report in Australia written by consultant HRL Technology and illustrates the probability of sustained ignition in the function of arcing time for currents of 4.2 A, 50 A, and 200 A.

The testing was performed under realistic worst-case conditions by Australian standards such as those during the infamous Black Saturday Victorian bushfire event. Testing parameters were as follow:

- Air temperature: 115 °F
- Windspeed: 6.21 mph
- Contact surface: Hay/straw
- Moisture: 5%



**Figure 7-1. Probability of Sustained Ignition in Function of Time and Fault Current**  
*Reprinted from Probability of Bushfire Ignition from Electric Arc Faults (p. 10),  
 by HLR Technology, December 2011, Victoria, Australia.*

Figure 7-1 shows how current based ground relaying practice is challenged when it comes to fire ignition mitigation, particularly for high impedance faults yielding very low current. The combination of sensitivity and speed required to mitigate those types of events is not practicable in a ground overcurrent relay without jeopardizing the security of the scheme and ultimately, continuity of system operation.

Table 7-3 presents the key benefits and limitations for SDG&E “advanced” ground relaying practice.

**Table 7-3. Key Benefits and Limitations of SDG&E “Advanced” Ground Relaying Practice**

Benefits	Limitations
<b>Intermittent Faults Coverage:</b> Intermittent ground faults should be covered with the spike counting algorithms.	<b>Sensitivity:</b> Still limited by system parameters: <u>Ground element:</u> 1-minute average load unbalances.
<b>Availability:</b> Required equipment/technology already mostly deployed on reclosers and feeder IEDs.	<b>Speed:</b> Spike counting algorithms could be relatively slow depending on the spike’s frequency and count. Adaptive Ground Element is currently set to operate at the same speed as SGF which is not ideal for ignition risk mitigation.



**Sensitivity:** Improvement over Profile 3 and SGF pickups. Self-learning adaptive ground element pickup based on IED buffer 1-minute unbalance average.

**Security:**  
SDG&E has experienced cases of spurious tripping due to spike counting functions.  
Raw spike counting function is currently disabled to prevent sympathetic tripping.

**Ignition:** Risks will be reduced for earth faults.

**Ignition:** Risks not completely mitigated.

### 7.2.2 Distribution Falling Conductor Protection (DFCP)

Over the last few years, SDG&E has started to deploy a novel fire ignition prevention tool for its distribution system. The distribution falling conductor protection (DFCP) core principle relies on the detection of an event – in this case, a broken conductor – prior to it striking the ground and causing a fault and risk of ignition and further safety hazards. The affected circuit section is therefore de-energized while the conductor is still falling following its break.

The scheme utilizes IEDs with PMU streaming following IEEE C37.118 standard and ethernet capability along the distribution feeder main trunk, major laterals, and substation breaker relay that are reporting synchrophasor packets (analog and binary values) back to the substation dedicated DFCP controller. The DFCP controller, which has embedded phasor data concentrator (PDC) capability, is taking care of the protection processing logic, the IEC 61850 GOOSE messages publication and subscription, and SCADA data alignment for the distribution control center (DCC). Communication between the DFCP controller and feeder deployed IEDs is done either through direct fiber optic for easily accessible areas or through wideband Ethernet radio for rural areas. Private LTE is also being deployed throughout SDG&E’s HFTD territory to bolster communication for DFCP. Interrupting devices along the feeder are tripped upon reception of GOOSE messages generated by the scheme controller.

As mentioned in the previous sections detailing SDG&E ground relaying practice, one of the main constraints for HIF detection is the ground overcurrent pickup element sensitivity being restrained by the standing unbalance of the circuit it is protecting. DFCP protection philosophy avoids altogether moving into a HIF scenario for faults involving a broken conductor.

The DFCP protection algorithm is current measurement independent and depends on patterns of changes in voltage synchrophasors to detect falling conductor conditions within milliseconds following a break. The scheme uses the following three methods to declare a broken conductor on the circuit:

1.  $dV/dt$
2.  $V_0$  and  $V_2$  magnitude
3.  $V_0$  and  $V_2$  angles

The main benefit of this fault detection principle is its ability to detect a potentially hazardous event before it occurs. This represents a valuable tool to add to a protection-based fire ignition mitigation program. Besides ignition risks, broken conductor situations pose a serious threat to public safety and, thus, being able to detect this scenario beforehand constitutes a significant benefit of the DFCP scheme.



One of the main considerations in deploying the DFCP scheme is the communication requirements. The DFCP principle relies primarily on highly granular voltage measurements from all interrupting devices located on the feeder’s main trunk, laterals and termination points of all distribution circuit branches. Complete “visibility” of distribution feeders is not economically feasible. Given the economical constraints, broken conductor events can only be detected on the feeder main trunk and major 3-phase laterals longer than 0.5 miles. It must also be stressed that the conductor needs to be broken for a fault to be detected. Downed conductors without a break need to be handled by other HIF detection algorithms listed previously in Section 7.2.1.3. Consequently, it is fair to say that the DFCP scheme, while excellent at what it does, is not necessarily the most versatile tool as it can only detect conductor breaks located on specific sections of the distribution circuit.

It is also important to note that while DFCP relies heavily on the availability of high speed and large bandwidth communication equipment, it is somewhat of a double-edged sword as the additional equipment utilized for DFCP can also be utilized to meet additional business objectives such as wide-area situational awareness (WASA) used for disturbance monitoring, system model validation, DER monitoring, load flow, and other applications.

Table 7-4 presents the key benefits and limitations for SDG&E DFCP relaying practice.

Table 7-4. Key Benefits and Limitations of SDG&E DFCP Relaying Practice

Benefits	Limitations
<b>Public safety benefits:</b> When tripping is enabled, it can isolate the conductor before evolving in challenging HIF and hazardous situations.	<b>Versatility:</b> Fault detection limitation. Open conductor fault types only. Faults can only be detected if located on the main feeder branch or a major lateral where equipment is installed.
<b>WASA friendly:</b> Requirements for additional IEDs/meters with PMU capability also support WASA numerous applications.	<b>Communication requirements:</b> Heavy (High speed, Large bandwidth).
<b>Ignition:</b> Risks mostly mitigated for falling conductor scenarios.	<b>Ignition:</b> Risks not completely mitigated.

### 7.2.3 Public Safety Power Shutoff (PSPS)

PSPS refers to the practice of shutting off specific sections of the distribution system when meteorological conditions are pointing towards high ignition risk probabilities. As the name implies, this practice aims at protecting the public from any hazardous situations such as fire ignition caused by the utility.

While this practice is more of a “workaround” and temporary solution to ignition risk mitigation, it does have the benefit of drastically reducing the chance of ignitions on the de-energized circuit provided that there are no sparks or other ignition threats prior to a PSPS event. With that said, this practice does not address the root causes at stake and can only be sustained during a limited time window (Red Flag period) as a safety measure. Additionally, this practice is also localized and circuits that are not de-energized will



still be prone to fire ignition. Outages have to be limited and planned carefully as they may also limit the ability of local communities to deal with fires and other potentially hazardous situations.

Lastly, PSPS outages are logistically and labor-intensive and can be very challenging for the utility and its staff involved. Before reenergizing any circuits, it must all be thoroughly patrolled either aerially or on the ground by qualified personnel.

Table 7-5 presents the key benefits and limitations for SDG&E PSPS practice.

Table 7-5. Key benefits and limitations of SDG&E PSPS practice

Benefits	Limitations
<b>Ignition:</b> Distribution system shutdown therefore ignition risks should be mostly mitigated for the de-energized sections.	<b>Logistics:</b> Extensive outages and can be logistically challenging.
	<b>Labor intensive:</b> Before reenergizing the circuits under PSPS, extensive ground and aerial patrolling of each circuit is required.
	<b>Adverse effect:</b> Outage might limit affected community capability to fight fires and manage emergencies.

#### 7.2.4 Restricted Earth Fault Current Limiter (REFCL)

REFCL protected distribution systems handle permanent and transient earth faults by displacing the network voltages, thereby quenching the fault current almost completely so that most faults will vanish as the arcs self-extinguish. With the synergy of the ASC and RCC, the current magnitude for an earth fault can be reduced to a level that will reduce the probability of fire ignition under most types of physical environments and meteorological conditions.

It must be stressed that for geographical areas going through long rain drought and heatwaves such as California and Australia, even small residual self-extinguishing currents can be an ignition hazard if sustained for long enough. Hence the need to be on the precautionary side and de-energize any faulted circuits even when REFCL equipment is enabled at the station. Reclosing should also be driven to lockout upon a fault’s detection.

As previously mentioned, earth fault management is crucial in ignition risk mitigation. The main gain obtained with REFCL technology over other conventional ground relaying solutions is the ability to perform in low fault current ranges that overcurrent-based protection can’t detect due to security constraints. REFCL technology addresses both root causes controllable by the utility, i.e. fault current magnitude and sustained time. The probability of fire ignition caused by earth faults will be reduced significantly if the REFCL equipment is properly calibrated and phase balancing is accomplished. Refer to Section 4 for more details on the phase balancing requirement for REFCL technology.



Existing sensitive phase protection used in SDG&E Profile 3 setting group deployed during a Red Flag condition can be operated in conjunction with the REFCL equipment when enabled to provide a supplemental line of defense targeting phase faults of lesser magnitude.

Ground relaying practices presented in Section 7.2.1 are not compatible with the REFCL protection philosophy, and specific operational practices will need to be developed to ensure that the two different ground relaying principles are not operated simultaneously while REFCL equipment is enabled. This does not represent a significant drawback but something to be mindful about that may add an extra layer of control logic.

Most downsides associated with the deployment of REFCL equipment are related to the drastic change in ground relaying fundamental principles and the recentness of the technology. Moving from a current-based protection scheme towards a voltage based one represents a paradigm shift that utility engineers will have to manage on the fast track. This grounding system methodology change also entails the implementation of novel fault detection and location principles, including harmonics and admittance-based protection algorithms. The concurrent introduction of considerably new technologies on the SDG&E distribution system would make it challenging to see the short-term benefits. This technological change comes with a steep learning curve and payback may only be achieved several years after the initial deployment.

With an almost complete suppression of current for earth faults, the existing SDG&E fault location process based on analysis of faulted feeder IED event reports will no longer be possible and will hence remove a valuable tool to the already challenging process of fault location on distribution circuits.

Another aspect to be considered is the lack of suppliers offering the REFCL technology as described in this document (ASC and RCC combined). As of now, this market is a monopoly owned by Swedish Neutral and technological advancement is seldom associated with this type of equipment. The current lack of manufacturer diversity is likely to cause procurement challenges as well, notably in terms of equipment manufacturing lead time, pricing, replacement parts availability, training, and after-sales services. This represents a considerable business risk that needs to be carefully analyzed before moving ahead with this new fire ignition mitigation strategy.

Finally, while REFCL is a promising technology available to electric utilities for fire ignition prevention, its overall cost can be a deterring factor. As estimated in this report, the cost associated with the new REFCL equipment, the existing equipment hardening or replacement, the feeder phase balancing, and all other costs associated with this change (engineering, labor, standardization, training, operational procedures and overhead costs) will be significant. Judicious identification of prospective deployment sites will help to get the maximum benefits of this technology and justify its associated cost.

Table 7-6 presents the key benefits and limitations of REFCL technology.



Table 7-6. Key Benefits and Limitations of REFCL Technology

Benefits	Limitations
<p><b>Reduces ignition risk for phase-to-ground faults:</b> Ground fault current suppression and fast operating time.</p>	<p><b>Does not cover all fault types:</b> Any fault involving multiple phases cannot be mitigated by REFCL. Wire slaps, multi-phase vegetation or other debris contacts, etc. will result in high fault current regardless of whether REFCL is installed on the system.</p>
<p><b>Compatibility:</b> Existing and more intuitive ground relaying practice can be kept when REFCL not enabled.</p>	<p><b>For some utilities like SDG&amp;E, the distribution system would need to be rebuilt just to accommodate REFCL due to issues such as incompatible voltage ratings, phase-to-neutral connected loads, and imbalanced capacitance across three phase systems.</b></p>
<p><b>Ignition:</b> Risks will be reduced for phase-to-ground faults.</p>	<p><b>Ignition:</b> Risks not completely mitigated.</p>
	<p><b>Paradigm shift:</b> Distribution protection based on voltage vs current. Steep learning curve and a long time before achieving full benefits.</p>
	<p><b>New technology/Limited lessons learned:</b> The market is a monopoly for now with very few competing vendors. Not a fully mature technology. Requires thorough testing and a lot of knowledge exchanges with limited existing users.</p>
	<p><b>Costs:</b> Procurement, engineering, and training costs are high.</p>

### 7.3 SDG&E Wire Down and Other Fire Ignition Causes Evaluation

There are several types of events that can lead to fire ignition on a distribution system. One of the most important ones that utilities must deal with is wire down events. Overhead conductors can be broken or have their support poles knocked down by acts of nature or accidents, bringing the conductors to ground level and causing a hazardous situation.

Distribution lines are exposed to many conditions that can lead to premature aging and mechanical strength diminution. The main aging mechanism can be attributed to conductor corrosion, galvanic corrosion or fatigue, and fretting from aeolian vibration. Conductors can also be weakened or break abruptly due to lightning strikes, power arcs, gunshots, fires, tree strikes, car hits, etc. If the conductor breaks, depending on where the break happens, it may remain suspended in the air, fall to the ground or get in contact with its supporting structure or any other surfaces above ground level. In all these cases, an



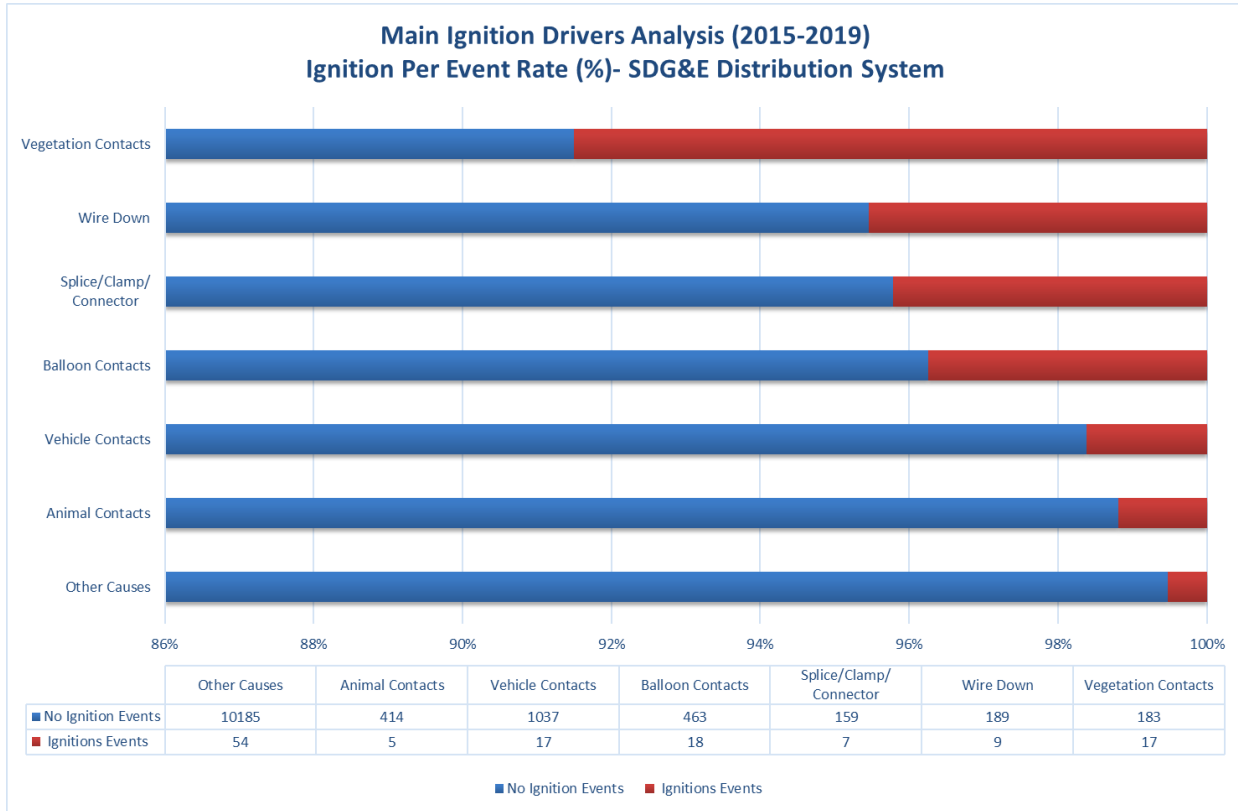
ignition threat exists if the conductor gets in contact with any form of flammable surfaces (tree, hay, straw, brushes, etc.). If a good quality contact is established with a reasonably conducting surface, there's hope that HIF relaying could detect that type of faults. The worst-case scenario for the detection of such events is if the conductor bounces on the ground causing an intermittent fault situation or if it remains hanging in the air. Section 7.2.1.3 of this report describes how these different types of faults can be mitigated using different protection relaying algorithms available at SDG&E.

The second type of wire down event occurs when a conductor falls, makes contact with the ground, and remains unbroken. This type of situation can arise for reasons that are similar to those highlighted in the previous paragraph and will pose similar treats of fire ignition and public safety as well.

Based on statistics from 2015 to 2019 provided by SDG&E, at distribution level voltages, SDG&E has experienced a total of 198 wire down events for an average of 39.6 per year. From that total of wire down events, fire ignition was initiated 9 times for an average of 1.8 times/year. This means that in 4.55% of the wire down events registered, fires were ignited. It should be noted that the data available does not distinguish between Red Flag and normal operating conditions. The ignition rate for wire down events is likely higher than the average obtained from both operating conditions.

Figure 7-2 shows the most frequent causes of fire ignition events on the SDG&E distribution system in terms of quantity and ignition rate per event (%), and it highlights clearly that the most frequent type of event causing fire ignitions is all related to contacts made with distribution system equipment. The top three fire ignition contributors are balloon, vegetation, and vehicle contacts with respectively 18, 17, and 17 events recorded from 2015 and 2019. Wire-down events are ranked fourth in terms of the number of fires ignited for that same period.





**Figure 7-2. Percentage (%) of Ignition vs Non-Ignition Events for Main Ignition Drivers**  
*SDG&E Distribution System Data (2015-2019)*

It is worth noting that some events are significantly more likely than others to ignite a fire when they arise. For instance, when vegetation comes in contact with a conductor or any other energized components of the system, it has a probability of ignition of 8.5% based on historical data. However, while animal contact is a prevalent type of event, statistics show that it is not as likely to cause ignition. That type of event has an ignition rate of only 2.15% meaning that it is approximately 4 times less likely than vegetation contacts to cause ignition upon occurrence. Figure 7-2 also illustrates that amongst the main ignition driver on the SDG&E distribution system, wire-down events have the second-highest rate of ignition with 4.55%.

It is important to mention that vegetation contacts ignition rate has been reduced in the last few years due to SDG&E increased mitigation efforts. Figure 72 does not capture the improvements made in that regard.

Figure 7-3 shows the reduction in fire ignition rate caused by vegetation from 2015 to 2019.

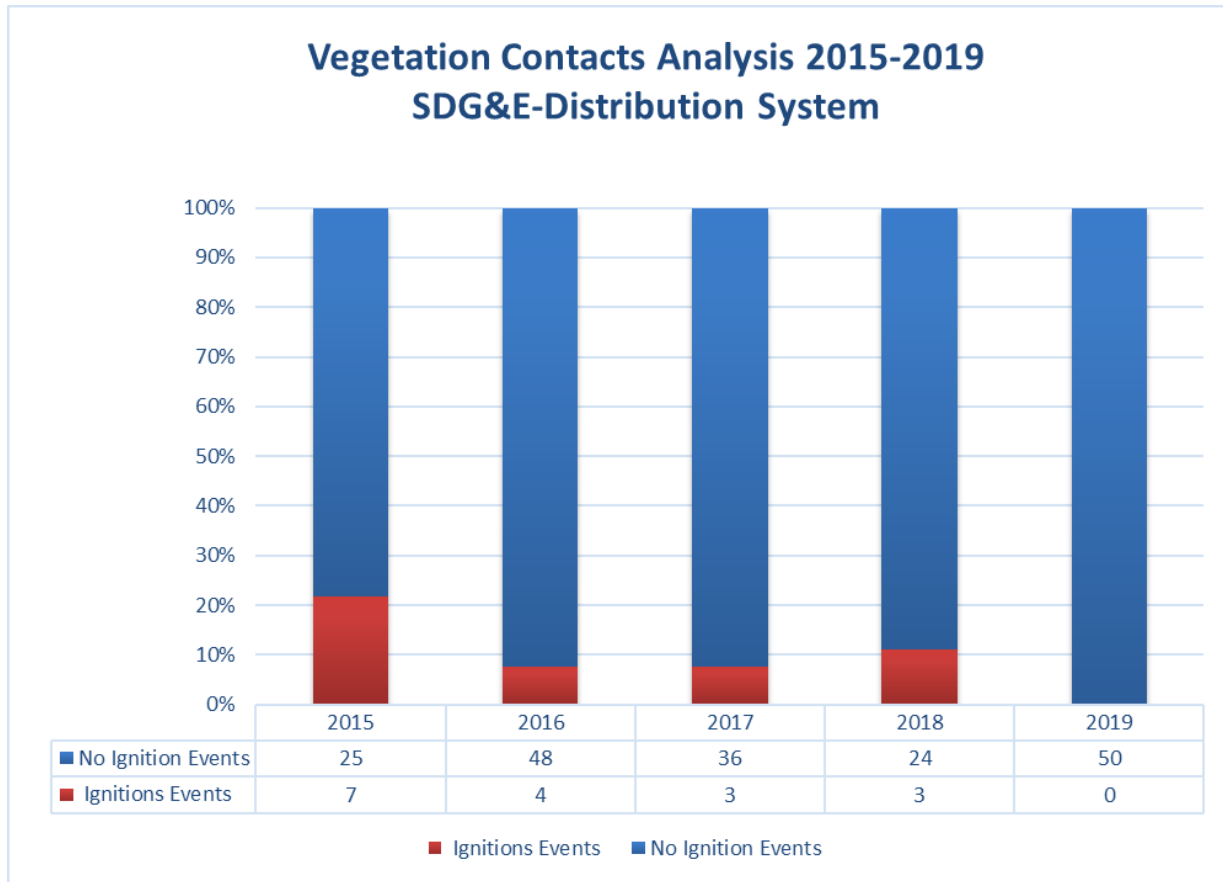


Figure 7-3. Percentage (%) of Ignition vs Non-Ignition Events for Vegetation Contacts  
SDG&E Distribution System Data (2015-2019)

While it is impossible to put an exact number on fire ignition incidents that could have been averted using REFCL technology during this recorded time, there is a reasonable chance that a good amount of events depicted in Figure 7-2 could have been prevented (Given that those events had evolved into an earth fault and that no fire had already been ignited prior to detection).

#### 7.4 REFCL End User Questionnaire

A questionnaire has been provided to an REFCL technology end-user to gather more information on the technology and the practical experience from a utility perspective. The complete questionnaire with detailed answers from the surveyed utility has already been made available to SDG&E. A high-level summary of the most relevant questions and responses received is provided below.



**1. Q: Is circuit capacitance balancing done solely based at the feeder head/breaker or is it balanced by feeder section that may be operated while REFCL is activated, such as in between SCADA switches or reclosers?**

A: We balance each feeder down to the remote operable switching section (provided by reclosers and SCADA switches). This is done through either growing or reducing the feeder and taking measurements at the zone substation while the station is low impedance earthed.

**2. Q: Do you install field balancing equipment? If yes, how do you connect/install balancing equipment (would you have a photo)?**

A: Yes, we install LV capacitor banks as one of the options to achieve capacitive balance. We have both a single-phase and a three-phase version of the LV capacitor bank.

**3. Q: For determining the capacitance unbalance, what methods are used for calculating and measuring the unbalance?**

A: Network data is used to calculate the unbalance for each of the remote switching sections. Network switching is then arranged to validate the balancing calculations and fine-tune the unbalance using the LV cap balancing units. Measurements are taken at the source substation.

**3a. Q: How accurate did you find those measurements and/or calculations to be?**

A: The accuracy of the calculation depends on how accurate our line data is. Achieving good accuracy in the substation measurement is also difficult due to the small amounts of current being measured. We have also found that other factors (such as mutual coupling with sub-transmission circuits) can affect capacitive balance.

**4. Q: How do you consider/prevent capacitive unbalance based on blown fuses?**

A: Currently we do not have a simple solution for this. We are trialing the use of fuse saver technology with ganged operation this year. We also undertake a risk assessment on each fuse and consider other options such as:

- Replacing fuses with and ACR
- Reconductoring

**5. Q: What is the unbalance level of line capacitance allowed in %?**

A: To operate our GFN equipment in the most sensitive Set Point we aim to limit the unbalance on each feeder to <80mA. Consideration must also be given to the angle of the unbalance as all feeders connected to a busbar will summate at the start point of the main substation transformer.

This total unbalance current will ultimately drive the neutral displacement measured.



**6. Q: How do you detect, find, and isolate a wire down if there is no fault current due to the arc being extinguished?**

A: Our current practice is to use a combination of line patrols and manual switching. We have trialed and are currently rolling out a sensitive fault detection algorithm in our Noja reclosers. This will give an indication of fault direction (i.e. forward and reverse).

**7. Q: Do you employ more than two protection group settings?**

A: The four setting groups are as follows:

- Group 1 is for Normal Forward in NER mode
- Group 2 is for Alternative Forward and Reverse in NER mode
- Group 3 is for TFB (total fire ban) in NER mode
- Group 4 is for REFCL

Group 3 is enabled when the area in which the recloser is located is declared as a total fire ban day (very high fire danger). Group 4 enables additional elements for high impedance fault detection when the area is protected by a REFCL.

**8. Q: Do you measure the ground current for the protection and compensation via conventional CTs (Holmgren circuit), Donut CT, or Rogowski coils?**

A: We use core balance CTs for our REFCL protected feeders. These vary in class depending on the station and are required to allow us to achieve the sensitivity defined by the regulations. We have trialed Rogowski coils but found the units we trialed (Phoenix) to be inadequate.

A Holmgren connection is used for the bus and transformer zones where lower sensitivity is required. In some cases, we have also had to install a core balance CT for the transformer zone where the phase CTs are not well matched.

**9. Q: Do you use a grounding transformer to provide a ground reference for the ARC? If yes, what are the advantages?**

A: All but one of our stations have power transformers with star connected 22kV windings therefore, grounding transformers are not used. One of our stations has a delta connected winding on the 22kV side which uses a neutral earthing compensator (NEC) to provide the ground reference.

**10. Q: How successful has the addition of REFCL been in preventing fires and extinguishing arcs?**

A: Given that we are only just approaching the end of our first summer with our REFCLs operating at required capacity by the regulations, we have not had time to collate our experiences.

**11. Q: What other fire mitigation strategies and concepts for fire prevention were evaluated and how was the decision made to use REFCL?**

A: The decision to use REFCL technology was made after the Victorian Government passed new laws that were framed in terms that meant we could only comply with them if we used REFCLs.



We also have other measures that support fire prevention on TFB days such as different setting groups on our ACRs and an increased focus on vegetation management.

**12. Q: Have you experienced any unforeseen primary equipment failure after deploying REFCL technology on your system? If so, what type of equipment and what was the cause of failure?**

A: Both in initial network hardening testing and in-service operation of our REFCL systems we have experienced failures of surge arresters and pole top substations. In some cases, we have identified classes of each that appear to be appropriately rated but have a high failure rate in practice. We have also had several high voltage cable failures due to the elevated voltages caused by operating a REFCL system.

**13. Q: With REFCL implementation, does the circuit remain energized while the problem is found and fixed, or, is the circuit de-energized while the cause is located? How fast do you remove the faulted circuit from the system?**

A: We do not practice continuous compensation; after the fault is confirmed as being permanent, the faulty element is tripped. Typically, this can take between 5 and 12 seconds.

**14. Q: How long can you operate (by regulations) with an “energized wire on the ground” situation?**

A: At present we are not allowed to continuously compensate single phase to earth faults. The longest time we have decided to allow based on a risk assessment is 21s (back-up protection time).

**15. Q: What Measurement transformers were used?**

A: Phase current (ratio, rated burden, class)

- Core 1: 600/400/5 0.2PX100 R0.15 40VA
- Core 2: Not used
- Core balance (ratio, rated burden, class): 200/1 0.2S 1.5VA or 100/1 0.5S 1.5VA

**16. Q: What are the major cost factors incurred by installing the new REFCL equipment?**

A: Without going into the individual costs of each project, the GFN unit price is typically 20% of the total station works when switchgear replacements were required. We have also spent a significant amount on lines works including asset replacements and capacitive balancing. This amounted to approximately \$10mil (AUD) for our 9 Tranche 1 stations.

**17. Q: What parts to you store as spare parts (if any)?**

A: Given there is no local support and the REFCLs are critical in supporting our summer bushfire mitigation plan, we carry spares of all the equipment we deem critical. These include one each of the arc suppression coil, RCC inverter, and grid balancing cubicle. We also carry spares of the key components of the control system such as:

- Master and Slave Racks
- Digital and Analogue I/O Cards.
- CPU Cards
- HMI Panel PC



Finally, we have many miscellaneous items such as the contactors found in the RCC and ASC, capacitors, auxiliary switches, etc.



## 8 SUMMARY

The application of the REFCL concept within the Descanso Substation is doable with the equipment containers provided by Swedish Neutral. There are multiple challenges to overcome prior to implementation, which include the implementation of new technology and upgrades required on the distribution system. Following implementation, operational challenges will also need to be addressed.

Provided cost estimates are based on currently available information. The cost methodology to perform these estimates centered around using SDG&E’s Work Order Authorization form for substation and distribution capital projects and their estimated indirect costs. The substation costs were calculated for two optional installations of either a self-contained GFN container or providing a separate AC station service from the main substation 12kV bus. The substation options were evaluated using estimated direct and indirect costs which verified by SDG&E Substation engineering. Additional SDG&E costs in the substation estimates included costs of removal of the 69kV grounding bank, the grounding bank foundation and oil containment, and in-house assistance and support. The distribution system replacements, phase swaps, and capacitor balancing units were estimated based on expected daily vehicle and crew rates to perform the work along with the direct and indirect cost of all materials. No salvage credits were assumed.

Table 8-1 shows the overall resultant cost to implement REFCL at the Descanso Substation. This scenario is provided because it is the lowest cost scenario identified (although, the four scenarios estimated are only within a few percentage points of each other). Option 2 is the GFN container option that does not include the zigzag grounding transformer. Solution 1 uses only capacitors for phase balancing. The four scenarios and detailed estimates are included in Appendix A.

Table 8-1. Option 2 and Solution 1 Summarized Costs (includes 30% Contingency)

Description	Estimated Cost
Descanso Substation	\$3,505,207
Transformer Replacements	\$7,347,351
Arrester Replacements	\$4,173,149
Phase Swaps	\$0
Cable Replacements	\$10,582,682
Capacitor Balancing Units	\$235,009
Miscellaneous	\$295,685
<b>Total for Option 2 and Solution 1</b>	<b>\$26,139,083</b>



The use of REFCL technology with the objective to reduce the probability of fire ignition for ground faults is a relatively new application that has been installed in Australia and other countries over the last 5 years. At this time, no reliable statistical data is available that documents how successful this scheme can mitigate fire risk. The use of an arc suppression coil for system grounding has been in use all over the world for over 100 years and all challenges are well understood and documented. REFCL, in addition, uses a residual current compensation (RCC), and its impact on the power system and fault behavior must be investigated prior to the pilot project. Testing should be pursued, to determine how well the REFCL prevents ignition, how the system will impact the power system, how well the GFN protection system can detect a fault that has occurred, and which circuit had the fault. Also, high voltage testing should be considered for confirming if existing equipment can withstand the overvoltage. Testing can also confirm if the secondary capacitors operate as expected.

An option to consider is developing additional cost estimates for the implementation of REFCL at additional substations in high fire risk areas.





## 9 REFERENCES

---

- [1] Kersting, William H. *Distribution system modeling and analysis*. CRC press, 2012.
- [2] IEEE 141-1993 (R1999) Recommended Practice for Electric Power Distribution for Industrial Plants, IEEE Red Book
- [3] RUS Bulletin 1724E-300 Design Guide for Rural Substations, June 2001
- [4] NFPA 70 2017, Article 310.106
- [5] The Okonite Company, Percent Insulation Level, Edition 0027, February 2009
- [6] IEEE 48-2009 Standard for Test Procedures and Requirements for Alternating-Current Cable Terminations Used on Shielded Cables Having Laminated Insulation Rated 2.5kV through 765kV or Extruded Insulation Rated 2.5kV through 500kV
- [7] IEEE C57.12.00-2015 Standard for General Requirements for Liquid-Immersed Distribution, Power, and Regulating Transformers
- [8] IEEE Standard 1313.2-1999 The Application of Insulation Coordination
- [9] IEEE C57.19.00-2004 IEEE Standard General Requirements and Test Procedures for Power Apparatus Bushings
- [10] IEEE C2 – 2017 National Electrical Safety Code
- [11] IEEE C37.60 -2019 Standard High-voltage switchgear and controlgear – Part 111: Automatic circuit reclosers for alternating current systems up to and including 38kV
- [12] IEEE C62.22-2009, Guide for the Application of Metal-Oxide Surge Arresters for Alternating-Current Systems
- [13] IEEE C62.11-2012, Standard for Metal-Oxide Surge Arresters for AC Power Circuits (>1kV)
- [14] National Electrical Manufacturers Association Understanding the Arrester Datasheet
- [15] Swedish Neutral, “Ground Fault Neutralizer” Operation Manual, Revision A1, 2012
- [16] M. Loos, “Single Phase to Ground Fault Detection and Location in Compensated Network”, PhD Thesis, University Libre de Bruxelles, 2014



## APPENDIX A: COST ESTIMATE DETAILS

The estimated cost options for Substation Option 1 and Solutions 1 & 2 and for Substation Option 2 and Solutions 1 & 2 are provided in Table A-1. As described in previous sections of this report, Option 1 covers Swedish Neutral container design fully equipped with 12kV grounding transformer and voltage transformers, and Option 2 provides an alternative where the grounding transformer and voltage transformer are not included with the container. Substation Options 1 & 2 are shown in Tables A-2 and A-3. Solutions 1 & 2 provide cost estimates for capacitor balancing units and phase swaps (Tables A-4 and A-5). Tables A-6, A-7, and A-8 show cost estimates for arrester, cables, and transformer replacements, respectively. Miscellaneous work is shown in Table A-9.

Table A-1. Preliminary REFCL Installation Cost Estimates Options & Solutions

<b>Summary for Option 1 and Solution 1</b>		<b>Summary for Option 1 and Solution 2</b>	
Description	Estimated Cost	Description	Estimated Cost
Descanso Substation	\$ 3,827,432	Descanso Substation	\$ 3,827,432
Transformer Replacements	\$ 7,347,351	Transformer Replacements	\$ 7,347,351
Arrester Replacements	\$ 4,173,149	Arrester Replacements	\$ 4,173,149
Phase Swaps	\$ -	Phase Swaps	\$ 195,010
Cable Replacements	\$ 10,582,682	Cable Replacements	\$ 10,582,682
Capacitor Balancing Units	\$ 235,009	Capacitor Balancing Units	\$ 176,257
Miscellaneous	\$ 295,685	Miscellaneous	\$ 295,685
<b>Total Option 1 &amp; Solution 1</b>	<b>\$ 26,461,309</b>	<b>Total Option 1 &amp; Solution 2</b>	<b>\$ 26,597,567</b>
<b>Summary for Option 2 and Solution 1</b>		<b>Summary for Option 2 and Solution 2</b>	
Description	Estimated Cost	Description	Estimated Cost
Descanso Substation	\$ 3,505,207	Descanso Substation	\$ 3,505,207
Transformer Replacements	\$ 7,347,351	Transformer Replacements	\$ 7,347,351
Arrester Replacements	\$ 4,173,149	Arrester Replacements	\$ 4,173,149
Phase Swaps	\$ -	Phase Swaps	\$ 195,010
Cable Replacements	\$ 10,582,682	Cable Replacements	\$ 10,582,682
Capacitor Balancing Units	\$ 235,009	Capacitor Balancing Units	\$ 176,257
Miscellaneous	\$ 295,685	Miscellaneous	\$ 295,685
<b>Total Option 2 &amp; Solution 1</b>	<b>\$ 26,139,084</b>	<b>Total Option 2 &amp; Solution 1</b>	<b>\$ 26,275,342</b>

NOTE: \$1 discrepancy with the total presented in the body of this report is due to rounding.



Table A-2. Descanso Substation Cost Estimate Option 1

Description (Descanso Substation Opt 1)	Amount	Totals	Rate
Labor	\$80,830		
Material	\$1,274,509		
Subcontract	\$32,750		
Equipment	\$11,640		
Other	\$28,500		
<b>Subtotal</b>		<b>\$1,428,229</b>	
Labor Overhead	\$99,421		123%
Material Overhead	\$71,373		5.6%
Subcontract Overhead	\$18,052		55.12%
Equipment Overhead	\$652		5.6%
Sales Tax	\$101,961		8%
Consumables	\$1,617		2%
Small Tools & Equip	\$2,587		3.2%
Project Management	\$251,688		14.6%
Engineering	\$318,068		16.1%
<b>Subtotal</b>		<b>\$865,419</b>	
BK30G Removal & Relocate	\$83,231		
BK30G Demo Work	\$30,984		
4 mo standby support	\$26,534		
KY assist w/commissioning and outages	\$62,806		
FAT's Engineering	\$100,000		
Firewall	\$82,000		
Contingency (30%)	\$1,148,229		
<b>Subtotal</b>		<b>\$1,533,748</b>	
<b>TOTAL</b>		<b>\$3,827,432</b>	

**Assumptions:**

1. Lump sum (LS) quantities and overheads provided by SDG&E
2. Swedish Neutral quote includes:
  - a. Grounding transformer and VTs
  - b. Arc suppression coil/inductor
  - c. Residual current compensator
  - d. Control panel
  - e. 5 days commissioning and training at site
  - f. 3 days factory acceptance testing
3. 15kV breaker and bay
4. Single-phase 15kV recloser
5. Grounding study and grid testing
  - a. One 69kV grounding bank removed



**Table A-3. Descanso Substation Cost Estimate Option 2**

Description	Amount	Totals	Rate
Labor	\$42,396		
Material	\$1,204,375		
Subcontract	\$32,750		
Equipment	\$8,857		
Other	\$28,500		
<b>Subtotal</b>		<b>\$1,316,878</b>	
Labor Overhead	\$52,147		123%
Material Overhead	\$68,236		5.666%
Subcontract Overhead	\$18,052		55.12%
Equipment Overhead	\$496		5.6%
Sales Tax	\$96,350		8%
Consumables	\$848		2%
Small Tools & Equip	\$1,357		3.2%
Project Management	\$226,937		14.6%
Engineering	\$286,789		16.1%
<b>Subtotal</b>		<b>\$751,212</b>	
BK30G Removal & Relocate	\$83,231		
BK30G Demo Work	\$30,984		
4 mo. standby support	\$26,534		
KY assist w/commissioning and outages	\$62,806		
FAT's Engineering	\$100,000		
Firewall	\$82,000		
Contingency -- 30%	\$1,051,562		
<b>Subtotal</b>		<b>\$1,437,117</b>	
<b>TOTAL</b>		<b>\$3,505,207</b>	

**Assumptions:**

1. Lump sum (LS) quantities and overheads provided by SDG&E
2. Swedish Neutral quote includes:
  - a. Arc suppression coil/inductor
  - b. Residual current compensator
  - c. Control panel
  - d. 5 days commissioning and training at site
  - e. 3 days factory acceptance testing
3. Single-phase 15kV recloser
4. 12kV voltage transformer and station service transformers
5. Grounding study and grid testing
  - a. One 69kV grounding bank removed



The following estimates are calculated based on SDG&E WOR-C for OH Working Foreman Four Man Crew. Materials and other assumptions are stated in their respective sections in the report.

**Table A-4. Capacitor Balancing Units Cost Estimate**

<b>Solution</b>	<b>#1</b>	<b>#2</b>
Single-Phase Installation	4	4
2-Phase Installation	6	4
Single-Phase Units Total	16	12
Estimated Travel Time (hr)	2	2
Estimated Work Time (hr)	6	6
Daily Crew Rate (Direct)	\$3,896	\$3,896
Daily Crew Rate (Indirect)	\$8,740	\$8,740
Daily Vehicle Rate	\$600	\$600
Estimated Total Days (2 units per day)	8	6
4-Person Crews Required	1	1
Labor	\$101,088	\$75,816
Expenses	\$4,800	\$3,600
Single-Phase Unit Cost	\$74,888	\$56,166
<b>TOTAL COST</b>	<b>\$180,776</b>	<b>\$135,582</b>
<b>PLUS CONTINGENCY (30%)</b>	<b>\$235,009</b>	<b>\$176,257</b>



Table A-5. Phase Swap Cost Estimate

Solution	#1	#2
Units Swap	0	34
Estimated Travel Time (hr)	0	2
Estimated Work Time (hr)	0	6
Daily Crew Rate (direct)	0	\$3896
Daily Crew Rate (indirect)	0	\$8740
Daily Vehicle Rate	0	\$600
Estimated Total Days	0	11.3
Labor	0	\$143,208
Expenses	0	\$6,800
<b>TOTAL COST</b>	<b>\$0</b>	<b>\$150,008</b>
<b>PLUS CONTINGENCY (30%)</b>	<b>\$0</b>	<b>\$195,010</b>



Table A-6. Arrester Replacements Cost Estimate

Circuit No.	73	78	79
<b>Labor and Expenses</b>			
No. of Units Replaced	701	276	865
Travel Time (hr)	2	2	2
Work Time (hr)	6	6	6
Daily Crew Rate (Direct)	\$3,896	\$3,896	\$3,896
Daily Crew Rate (Indirect)	\$8,740	\$8,740	\$8,740
Daily Vehicle Rate	\$600	\$600	\$600
Estimated Units/Day (9 units)	78	31	96
Labor	\$984,204	\$387,504	\$1,214,460
Expenses	\$46,733	\$18,400	\$57,667
<i>Subtotals</i>	<i>\$1,030,937</i>	<i>\$405,904</i>	<i>\$1,272,127</i>
<b>Materials and Removal</b>			
Material Cost	\$87,625	\$34,500	\$108,125
Removal Cost	\$103,094	\$40,590	\$127,213
<i>Subtotals</i>	<i>\$190,719</i>	<i>\$75,090</i>	<i>\$235,338</i>
<b>TOTAL COST</b>			<b>\$3,210,115</b>
<b>PLUS CONTINGENCY (30%)</b>			<b>\$4,173,149</b>



**Table A-7. Cable Replacements Cost Estimate (includes 30% Contingency)**

Description	Direct	Indirect	Subtotals
Company Labor	\$2,765,130	\$2,284,747	\$5,049,877
Material	\$1,008,656	\$203,488	\$1,212,144
Other Charges	\$134,164	\$4,186,497	\$4,320,661
<b>TOTAL</b>	<b>\$3,907,950</b>	<b>\$6,674,732</b>	<b>\$10,582,682</b>

**Table A-8. Transformer Replacements Cost Estimate**

Type	Poles (Overhead)		Pads (Underground)	
	25kVA	50kVA	25kVA	50kVA
Units Replaced	605	23	11	1
Estimated Travel Time (hr)	2	2	2	2
Estimated Work Time (hr)	6	6	6	6
Daily Crew Rate (Direct)	\$3896	\$3896	\$3896	\$3896
Daily Crew Rate (Indirect)	\$8740	\$8740	\$8740	\$8740
Daily Vehicle Rate	\$600	\$600	\$600	\$600
Estimate of Units per Day (2 units)	302.5 days	11.5 days	5.5 days	0.5 days
Labor	\$3,822,390	\$145,314	\$69,498	\$6,318
Expenses	\$181,500	\$6,900	\$3,300	\$300
Transformer Cost	\$926,121	\$49,552	\$33,261	\$3,002
Removal Cost	\$382,239	\$14,531	\$6,950	\$632
<i>Subtotals</i>	<i>\$5,312,250</i>	<i>\$216,297</i>	<i>\$113,009</i>	<i>\$10,252</i>
<b>TOTAL COST</b>			<b>\$5,651,808</b>	
<b>PLUS CONTINGENCY (30%)</b>			<b>\$7,347,351</b>	





Table A-9. Miscellaneous Work Cost Estimate

	Remove 3-Phase OH Grounding Bank (P572497)	Reconfigure 3-Phase OH Open Delta Transformers to Closed Delta	Reconfigure 3-Phase Voltage Regulator w/Controller to Closed Delta
Units	1	16	1
Unit Price	\$12,636	\$12,636	\$12,636
<i>Subtotals</i>	<i>\$12,636</i>	<i>\$202,178</i>	<i>\$12,636</i>
<b>TOTAL</b>			<b>\$227,450</b>
<b>PLUS CONTINGENCY (30%)</b>			<b>\$295,685</b>

## **Appendix B: Weather Station Maintenance and Calibration**

---

## Weather Station Maintenance and Calibration

Station Name	Latitude	Longitude	Last Maintenance Date	Prior Maintenance Date	Days Between Maintenance	Notes
1928	33.076466	-116.591572	1/24/2023	3/31/2022	299	
1931	33.391884	-116.788183	7/10/2023	3/3/2022	494	
1934	33.210367	-116.509195	4/19/2023	3/2/2022	413	
1935	32.68471	-116.98005	7/13/2023	4/27/2022	442	
1921	32.82704	-116.77332	6/13/2023	3/11/2022	459	
1922	33.357149	-117.276548	7/27/2023	8/16/2022	345	
1923	33.55760	-117.54654	7/18/2023	5/4/2022	440	
1925	32.85239	-117.11801	1/19/2023	2/28/2022	325	
1927	33.06710	-116.84519	6/19/2023	4/6/2022	439	
1929	32.87828	-116.42359	7/5/2023	3/25/2022	467	
1930	33.35214	-116.86286	6/14/2023	3/7/2022	464	
1932	33.04940	-116.63691	6/28/2023	4/7/2022	447	
1936	33.47844	-117.4851	7/17/2023	7/13/2022	369	
1937	33.235668	-117.007696	7/20/2023	3/22/2022	485	
1939	32.85145	-116.89528	6/1/2023	3/3/2022	455	
1940	32.71384	-116.86904	6/15/2023	3/26/2022	446	
1941	32.86702	-116.89619	6/1/2023	3/3/2022	455	
1942	32.84329	-116.88113	6/1/2023	3/3/2022	455	
1943	32.91431	-117.02959	5/10/2023	4/21/2022	384	
1944	32.64449	-116.34617	6/11/2023	4/20/2022	417	
1956	32.98626	-116.90810	6/27/2023	4/19/2022	434	
1955	33.035112	-116.936045	6/22/2023	5/3/2022	415	
1954	33.04029	-116.95934	5/2/2023	4/18/2022	379	
1953	32.91247	-116.95207	6/4/2023	3/3/2022	458	
1952	32.93508	-116.87671	6/19/2023	3/17/2022	459	
1951	32.99606	-116.789346	6/19/2023	3/5/2022	471	
1950	32.86782	-116.84313	6/1/2023	3/4/2022	454	
1949	32.82216	-116.82896	6/4/2023	3/21/2022	440	
1948	32.68839	-116.51179	6/11/2023	5/10/2022	397	
1947	32.81147	-116.85429	6/4/2023	3/21/2022	440	
1946	32.63604	-116.11823	1/27/2023	3/16/2022	317	
1945	32.74504	-116.03780	1/27/2023	3/16/2022	317	
1957	33.284635	-117.01553	7/15/2023	3/15/2022	487	
1958	33.277137	-117.069299	7/12/2023	4/12/2022	456	
1959	32.845599	-116.706295	7/6/2023	4/6/2022	456	
1960	32.813235	-116.734115	6/2/2023	3/11/2022	448	
1961	32.78383	-116.72321	6/15/2023	3/26/2022	446	
1963	33.17799	-116.99470	6/30/2023	3/29/2022	458	
1964	33.07272167	-116.73793667	6/6/2023	4/4/2022	428	
1965	32.94015	-116.63601	5/5/2023	4/6/2022	394	
1966	33.16756	-116.75917	7/21/2023	3/31/2022	477	
1967	32.7008	-116.3683	4/27/2023	4/29/2022	363	
1968	32.84538333	-116.47192167	7/5/2023	3/25/2022	467	
1969	32.80849	-116.50830	6/11/2023	3/25/2022	443	
1970	32.59897833	-116.49292167	6/3/2023	3/18/2022	442	
1971	32.647954	-116.631439	3/9/2023	5/17/2022	296	
1972	32.61225167	-116.61333	7/6/2023	7/7/2022	364	
1973	32.68695	-116.76221	6/15/2023	5/2/2022	409	
1974	32.80833	-116.78871	6/9/2023	3/11/2022	455	

Station Name	Latitude	Longitude	Last Maintenance Date	Prior Maintenance Date	Days Between Maintenance	Notes
1975	32.73616	-116.8223	6/12/2023	5/17/2022	391	
1976	32.78689	-116.83620	6/4/2023	3/21/2022	440	
1977	33.56964	-117.51306	7/17/2023	5/4/2022	439	
1978	33.41921	-117.08186	5/16/2023	3/8/2022	434	
1979	33.45839	-117.29735	7/21/2023	4/1/2022	476	
1980	33.41892167	-117.14413	6/1/2023	3/10/2022	448	
1983	33.313212	-117.085753	7/27/2023	4/12/2022	471	
1984	33.23996	-117.04603	1/11/2023	3/24/2022	293	
1985	33.28779	-116.95642	7/13/2023	3/7/2022	493	
1986	33.247864	-116.697254	6/15/2023	2/2/2022	498	
1987	33.25843833	-116.58517667	4/19/2023	3/3/2022	412	
1988	33.22329	-116.69879	7/21/2023	3/4/2022	504	
1989	33.474123	-117.55057	7/18/2023	5/4/2022	440	
1990	33.1937683	-117.15301167	7/24/2023	8/18/2022	340	
1991	33.226173	-117.075588	7/11/2023	4/12/2022	455	
1992	33.28555667	-117.14574167	7/3/2023	3/28/2022	462	
1993	33.226505	-117.0941483	7/25/2023	3/28/2022	484	
1994	33.37111	-117.07893	6/21/2023	3/8/2022	470	
1995	33.02876	-116.79285	6/27/2023	3/5/2022	479	
1996	33.01566	-116.87089	6/2/2023	3/5/2022	454	
1997	33.10468	-116.60250	6/19/2023	3/31/2022	445	
1998	33.31236	-117.00349	7/13/2023	3/11/2022	489	
1999	33.35464	-117.16754	1/13/2023	3/28/2022	291	
1900	33.25143	-116.95707	7/14/2023	3/22/2022	479	
1901	33.25614	-116.98201	7/14/2023	3/15/2022	486	
1902	33.07300	-116.85802	6/27/2023	4/6/2022	447	
1903	33.07452	-116.81370	7/13/2023	4/4/2022	465	
1904	32.72022	-116.92783	1/26/2023	4/4/2022	297	
1905	33.09856	-116.82758	6/27/2023	4/6/2022	447	
1906	32.83006	-116.79944	6/9/2023	3/11/2022	455	
1907	32.66213	-116.28880	4/27/2023	3/16/2022	407	
1908	33.11312	-116.67182	7/14/2023	2/2/2022	527	
5131	32.633868	-116.423472	5/1/2023	3/18/2022	409	
5109	33.39251	-117.25470	7/20/2023	5/18/2022	428	
1910	32.601750	-116.684580	6/15/2023	5/2/2022	409	
1911	32.761954	-116.488620	6/3/2023	3/18/2022	442	
5112	32.647448	-116.496857	6/3/2023	3/18/2022	442	
5113	33.386152	-116.660754	2/1/2023	3/3/2022	335	
5114	32.78294	-116.54967	7/7/2023	4/28/2022	435	
5116	32.614958	-116.757605	6/15/2023	5/2/2022	409	
5117	33.22645	-116.62068	4/11/2023	3/12/2022	395	
5118	32.855273	-116.574251	6/16/2023	4/21/2022	421	
5119	33.03958	-116.56066	4/26/2023	5/18/2022	343	
5120	33.043933	-117.134647	1/12/2023	4/25/2022	262	
5121	32.713771	-116.403757	5/9/2023	4/29/2022	375	
5122	32.9974	-116.5951	7/3/2023	4/28/2022	431	
5123	32.93306	-116.52806	7/3/2023	4/11/2022	448	
5124	33.32219	-116.96191	7/24/2023	3/11/2022	500	
5126	32.883230	-116.646467	6/20/2023	3/26/2022	451	
5127	32.629814	-116.585044	6/15/2023	6/2/2022	378	
5128	33.08016	-117.12969	6/28/2023	4/15/2022	439	
5129	32.600136	-116.842527	6/9/2023	4/27/2022	408	
5130	33.13219	-116.68593	10/20/2023	3/12/2022	587	

Station Name	Latitude	Longitude	Last Maintenance Date	Prior Maintenance Date	Days Between Maintenance	Notes
5132	32.720943	-116.702441	6/16/2023	5/2/2022	410	
5133	33.34397	-116.73174	7/10/2023	3/3/2022	494	
5134	32.849519	-116.629856	7/12/2023	4/21/2022	447	
5135	33.031135	-117.122459	7/14/2023	4/26/2022	444	
5136	33.08678	-116.68974	7/20/2023	5/5/2022	441	
5137	33.10569	-116.65363	7/21/2023	3/31/2022	477	
5138	32.73203	-116.76183	6/12/2023	4/4/2022	434	
5139	33.262469	-116.348273	2/27/2023	3/2/2022	362	
5140	33.1371	-116.2943	1/3/2023	3/2/2022	307	
5141	32.814196	-117.240847	6/27/2023	3/4/2022	480	
5145	32.781375	-117.137571	4/18/2023	4/8/2022	375	
5146	32.963981	-117.22296	6/30/2023	3/23/2022	464	
5148	33.06714	-116.99011	7/13/2023	3/30/2022	470	
5149	32.9777	-116.7803	6/19/2023	3/5/2022	471	
5151	33.092501	-116.954482	7/14/2023	3/30/2022	471	
5152	32.7756774365528	-116.667847215792	6/16/2023	5/10/2022	402	
5153	33.224407	-116.92354	7/18/2023	3/14/2022	491	
5154	33.10301	-116.579742	6/8/2023	1/26/2022	498	
5155	33.307901	-116.85488	6/14/2023	3/7/2022	464	
5161	32.558135,116.900453	-116.900453	6/26/2023	4/27/2022	425	
5162	32.842286	-117.056411	7/7/2023	4/8/2022	455	
5163	33.068817	-116.709897	7/26/2023	3/12/2022	501	
5164	32.954055	-116.642846	6/20/2023	4/6/2022	440	
5157	33.43564	-117.58992	7/17/2023	5/23/2022	420	
5159	33.007305	-117.276228	6/30/2023	3/23/2022	464	
5158	33.13737	-117.327145	1/4/2024	6/30/2023	188	Calbration performed 1/24
5147	32.831738	-116.628345	6/21/2023	3/31/2022	447	
5165	32.836874	-116.682487	6/21/2023	4/6/2022	441	
5167	33.14437	-116.84725	6/27/2023	4/6/2022	447	
5166	33.082646	-116.65725	7/20/2023	3/4/2022	503	
5168	33.145631	-116.641266	7/21/2023	3/12/2022	496	
5171	32.86522	-116.74746	4/18/2023	3/14/2022	400	
5172	32.743504	-116.731999	6/12/2023	4/4/2022	434	
5174	32.859398	-116.767955	6/2/2023	3/21/2022	438	
5176	33.27605	-116.872899	6/15/2021	4/5/2019	802	As of 2023, crews have been unable to perform maintenance due to the access road being washed out. A new site is being assessed
5177	33.411286	-117.057177	5/16/2023	3/8/2022	434	
5179	33.068772	-116.761751	7/14/2023	10/19/2022	268	
5181	32.914475	-116.620218	3/3/2023	3/30/2022	338	
5173	33.328876	-116.980929	7/13/2023	3/11/2022	489	
5178	33.270666	-116.946043	7/14/2023	10/10/2022	277	
5175	32.817440	-116.520848	7/5/2023	4/1/2022	460	
1982	33.401221	-117.170167	6/1/2023	3/10/2022	448	
1933	32.606357	-116.57687	6/14/2023	4/29/2022	411	
5180	32.797668	-116.779248	3/2/2023	3/11/2022	356	
1915	33.301305	-116.912993	3/7/2022	8/24/2021	195	As of 2023, the property owner has denied SDG&E access to the station site. A

Station Name	Latitude	Longitude	Last Maintenance Date	Prior Maintenance Date	Days Between Maintenance	Notes
						new location is being assessed.
5191	32.790835	-117.184006	5/4/2023	4/8/2022	391	
5186	32.844262	-117.239726	6/27/2023	4/7/2022	446	
5190	33.129027	-117.19226	7/12/2023	4/1/2022	467	
5183	32.601591	-117.058007	7/6/2023	6/27/2022	374	
5160	32.541620	-117.096897	6/14/2023	3/3/2022	468	
5187	32.654335	-117.096691	7/6/2023	3/3/2022	490	
5185	32.79547	-116.972735	6/29/2023	5/5/2022	420	
5192	33.205472	-117.253897	1/4/2024	6/28/2023	190	Calbration performed 1/24
5182	32.736035	-117.06659	6/29/2023	4/5/2022	450	
5188	32.982024	-117.039851	7/24/2023	10/12/2022	285	
5189	32.971628	-117.117307	7/13/2023	5/3/2022	436	
1981	33.405571	-117.123725	7/3/2023	3/10/2022	480	
5169	32.86357	-116.6623	6/20/2023	4/6/2022	440	
5199	32.845642	-116.7524	6/2/2023	3/14/2022	445	
5193	33.142219	-116.9686	7/24/2023	3/29/2022	482	
5198	32.853929	-116.742395	6/2/2023	3/14/2022	445	
5196	33.220404	-116.959240	7/18/2023	3/14/2022	491	
5194	33.1667772148931	-116.954630582664	7/19/2023	3/29/2022	477	
5195	33.203064	-116.929448	7/18/2023	3/14/2022	491	
5197	33.368573	-117.040180	6/21/2023	3/8/2022	470	
1962	33.171640	-117.051447	6/30/2023	3/8/2022	479	
4802	33.113986	-117.152193	7/12/2023	4/25/2022	443	
4807	32.976119	-116.973139	4/17/2023	3/30/2022	383	
4806	32.997956	-117.0053	6/22/2023	4/21/2022	427	
4810	32.594318	-116.4668	5/1/2023	3/18/2022	409	
4805	32.8753	-116.9317	6/4/2023	3/4/2022	457	
4811	33.023051	-117.169214	4/28/2023	4/26/2022	367	
4800	32.994864	-117.132931	2/21/2023	5/3/2022	294	
4801	33.015079	-117.005047	7/8/2023	4/18/2022	446	
4812	32.6443	-116.3168	4/12/2023	3/26/2022	382	
4808	32.997340	-117.228098	7/14/2023	7/7/2022	372	
4809	33.040706	-117.029582	7/7/2023	4/18/2022	445	
4803	33.036759	-117.166174	1/18/2023	4/26/2022	267	
4804	33.075734	-117.191493	7/11/2023	4/7/2022	460	
4813	32.641860	-117.110449	6/13/2023	5/5/2022	404	
4822	33.059495	-117.121765	1/12/2023	4/25/2022	262	
4826	33.1581	-117.0333	6/30/2023	4/14/2022	442	
4823	33.097936	-117.130462	6/28/2023	4/25/2022	429	
4827	33.016832	-116.972033	6/22/2023	3/30/2022	449	
4824	33.059736	-116.881259	6/27/2023	3/30/2022	454	
4825	33.030521	-116.827807	7/20/2023	3/5/2022	502	
4829	32.685097	-116.546795	6/11/2023	3/18/2022	450	
4839	32.909025	-116.575519	4/26/2023	4/7/2022	384	
4817	33.26521786	-116.99357103	7/19/2023	3/15/2022	491	
4820	33.238424	-117.030305	7/11/2023	3/24/2022	474	
4814	33.248419	-117.010624	7/19/2023	3/24/2022	482	
4815	33.255853	-117.033763	7/11/2023	3/24/2022	474	
4845	33.262493	-117.085655	7/12/2023	4/12/2022	456	
4816	33.235369	-116.972891	7/20/2023	3/22/2022	485	
4846	32.854713	-116.600536	6/3/2023	8/15/2022	292	
4837	33.274119	-117.039375	7/24/2023	10/12/2022	285	

Station Name	Latitude	Longitude	Last Maintenance Date	Prior Maintenance Date	Days Between Maintenance	Notes
4847	32.864933	-116.633670	6/21/2023	3/27/2022	451	
4840	32.841364	-116.531321	6/3/2023	4/1/2022	428	
4838	33.431122	-117.280672	7/21/2023	4/2/2022	475	
4819	33.219727	-117.023209	7/24/2023	3/24/2022	487	
4830	33.426525	-117.121452	7/3/2023	3/10/2022	480	
4848	33.201970	-117.042192	7/11/2023	4/14/2022	453	
4844	33.343190	-117.205404	7/25/2023	4/1/2022	480	
4835	33.431738	-117.212391	7/21/2023	4/1/2022	476	
4821	32.845809	-116.785525	6/2/2023	3/14/2022	445	
4832	33.429310	-117.382769	7/17/2023	9/2/2022	318	
4834	33.413494	-117.283701	7/20/2023	4/2/2022	474	
4833	33.429249	-117.323876	7/20/2023	4/2/2022	474	
4828	32.658194	-116.557345	7/7/2023	5/10/2022	423	
4841	32.673289	-116.701321	7/12/2023	5/13/2022	425	
4843	32.960147	-116.874744	7/10/2023	3/17/2022	480	
4818	33.285820	-116.980023	7/19/2023	3/15/2022	491	
4831	33.154364	-117.083266	6/28/2023	8/6/2022	326	
1938	33.036349	-117.194609	7/11/2023	4/20/2023	82	



P.O. Box 129831 | San Diego, CA 92112-9831 | 1-800-411-7343 | Connect at **[sdge.com](https://www.sdge.com)**

© 2024 San Diego Gas & Electric Company. Trademarks are property of their respective owners.  
All rights reserved. Some materials used under license, with all rights reserved by licensor.  
Think before printing.