

# Covered Conductor - Everything You Need To Know (Compendium)

---

Prepared by Apparatus & Standards Engineering Group

T&D Engineering

October 8, 2018

# Purpose

- There has been a vast amount of literature search, testing, calculation, benchmarking and standards development by T&D Engineering for the deployment of Covered Conductor
- As a result, multiple work documentation on various topics concerning Covered Conductor has been created for supporting the issuance of SCE specifications, design and construction standards for covered conductor
- These topics on Covered Conductor are summarized on the “Table of Contents” slide.
- The purpose of this slide deck is to consolidate and condense the key thoughts of these works into a single document, providing a comprehensive overview of covered conductor

# Table of Contents

## Chapter I: What is Covered Conductor? Why Covered Conductor?

1. The Evolution of Covered Conductor Design
2. SCE Covered Conductor Design
3. Contact with Foreign Object
4. Wildfire Mitigation Effectiveness
5. Alternatives Comparison
6. Safety Advantages

## Chapter II: Life Expectancy

1. Manufacturer Survey
2. UV Protection
3. Environmental Stress-Crack Resistance
4. Track Resistance
5. Maximum Dielectric Constant
6. Production Tests
7. Covered Conductor Failure Mode

## Chapter III: Industry Benchmark and Research

1. Benchmarking
2. Industry Surveys
3. Incorporating Lessons Learned

## Chapter IV: Covered Conductor Construction

1. Covered Conductor Installation Guideline
2. Covered Conductor on 3 Phases and Neutral Analysis
3. SCE Covered Conductor Construction Diagrams

# Chapter I

## What is Covered Conductor?

## Why Covered Conductor?

# 1. The Evolution of Covered Conductor Design

This section introduces the high-level understanding of Covered Conductor and how it has evolved from a simple model in the early 1970s to a robust design today that mitigates contact issues and achieves long service life

# A Brief History

- Covered Conductor has been used by utilities since the 1970s in Europe and the U.S.
  - Key driver: reliability improvement in dense vegetation areas, such as forests in Scandinavia, the U.K., New England, etc.
- Other drivers expand the use of covered conductors:
  - Tokyo, Japan: public safety in dense population
  - Southeast Asia (Thailand, Malaysia): animal protection (snakes, monkeys, rodents), and dense vegetation, also public safety in downtown Bangkok
- Reduction of “bushfires” has become a key driver for replacing bare with covered conductor in Australia
- Over the years, significant development in the covered conductor design led to improved performance and extended life

# Nomenclature of Covered Conductor

- Covered conductor is a widely accepted and used term for distinguished from bare conductor
- The term indicates a conductor being “covered” with insulating materials to provide incidental contact protection
- Covered conductor is used in the U.S. in lieu of “insulated conductor”, which is reserved for grounded overhead cable
- Other parts in the world use the term “covered conductor”, “insulated conductor”, “coated conductor” interchangeably
- Covered conductor is a generic name for many sub-categories of conductor design and field construction arrangement
- Covered conductor in the U.S.:
  - Tree wire
    - Term was widely used in the U.S. in 1970’s
    - Associated with simple one layer cover
    - Used to indicate cross-arm construction
  - Spacer cable
    - Associated with construction using trapezoidal insulated brackets for suspending covered conductor
  - Aerial bundled cable (ABC)
    - Installation of underground cable on poles with benefits of being grounded
- Covered Conductor in Europe:
  - SAX, PAS/BLX, BLX-T are some names for covered conductor used in Scandinavia for installations in forests
  - CC/CCT are covered conductor and covered conductor with extra thickness are used in Australia, the Far East
- Covered Conductor at SCE:
  - The term “Covered Conductor” was introduced to SCE standards in Q1, 2018, previously, the term “tree wire” was used
  - SCE is more familiar with “aerial cable” to indicate field-bundled underground cable (with or without jacket) prior to 2000’s, and manufacturer “pre-bundled” underground cable on air (ABC) in the 2000’s
  - Current SCE specified Covered Conductor is more robust than CCT with has better UV protection

# Single Layer Covered Conductor

- Characteristics:
  - Single Layer
  - Typically, Low Density Polyethylene (insulating material)
  - Covering Thickness ranges from 0.091 to 0.130 inches
- Lower impulse strength than the two or three layer design
- Provides some resistance to outages caused by tree and wildlife contact





# Two Layer Covered Conductor

- Characteristics:
  - Two Layers
    - Layer A: Polyethylene (PE)
      - Insulating material
      - 0.080 inches
    - Layer B: High Density Polyethylene (HDPE)
      - Insulating Material
      - Tougher than layer A
        - Abrasion Resistant
      - 0.080 inches- Higher impulse strength than the single layer design



# Three Layer Covered Conductor

- Characteristics

- Three Layers

- Layer A: Conductor Shield

- Semiconducting layer
      - Reduces Voltage Stress

- Layer B: Polyethylene Layer

- Insulating Layer
      - Can be crosslinked (XLPE)

- Layer C: Polyethylene Layer

- Insulating Layer
      - Can be high density and/or crosslinked

- Higher impulse strength than the single layer design and two layer design



# SCE's Evolution

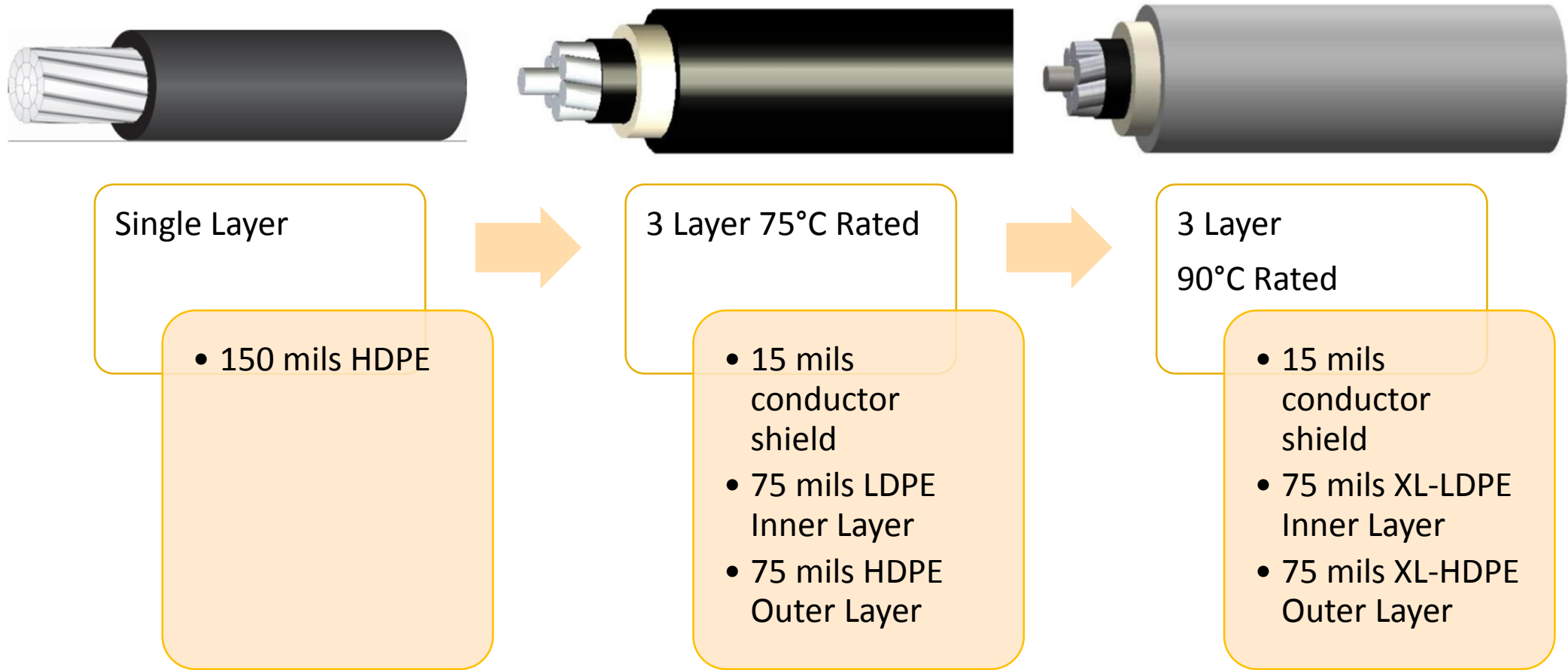

# Covered Conductor Installation Options

- Cross-arm Construction
  - (aka Tree Wire)



Most of SCE installations on Cross-arm (SCE uses grey to reduce the impact of sun light heating effect, thus increase ampacity)

- Compact Construction
  - (aka Spacer Cable)



Some installations will be space cable (e.g. replacement of tree attachments)

## 2. SCE Covered Conductor Design

This section provides more insights of SCE Covered Conductor Design – layer by layer and the functions of each layer (sheath)

# SCE Design

- Three Layer Covered Conductor

- Conductor
  - Aluminum Conductor Steel-Reinforced (ACSR)
  - Hard Drawn Copper (HDCU)
- Conductor Shield
  - Semiconducting Thermoset Polymer
- Inner Layer
  - Crosslinked Low Density Polyethylene
- Outer Layer
  - Crosslinked High Density Polyethylene

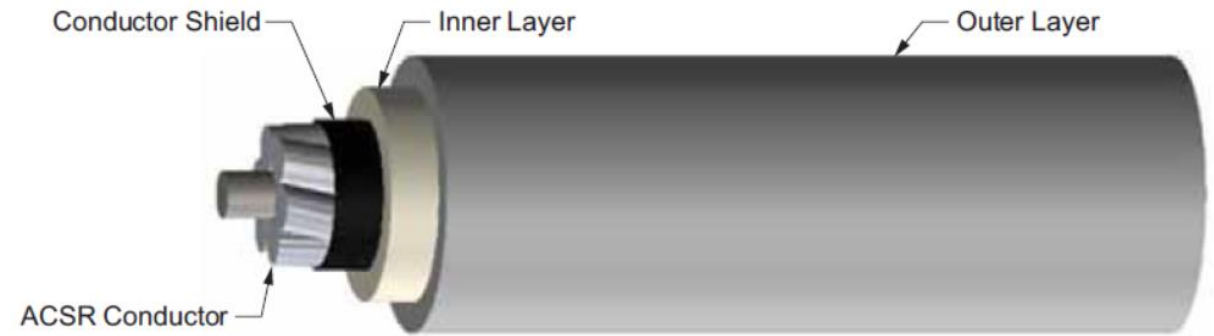

# Conductor

- Aluminum Conductor Steel-Reinforced (ACSR)

- Sizes

- 1/0 AWG (6/1 Strand)
    - 336.4 AWG (18/1 Strand)
    - 653 AWG (18/3 Strand)

- Hard Drawn Copper (HDCU)

- For use in coastal areas (within 1 mile of the coast)
    - Copper is more resistant to corrosion than Aluminum

- Sizes

- #2 AWG (7 Strand)
    - 2/0 AWG (7 Strand)
    - 4/0 AWG (7 strand)

# Conductor Shield

- Material: Semiconducting Thermoset Polymer
- Reduces stress concentrations caused by flux lines from individual conductor strands.
  - Transforms strands into a single uniform conducting cylinder

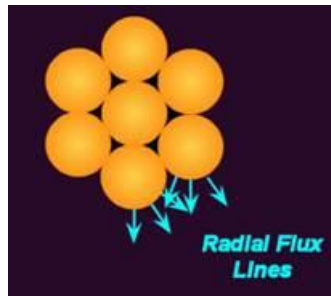

Flux lines without a conductor shield

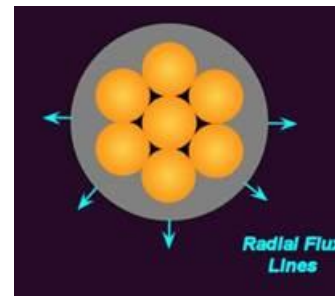

Flux lines with a conductor shield

- The reduction of electrical stress, especially if the covered conductor is in contact with another object, will help preserve the integrity of the insulation and lengthen the useful service life of the covered conductor.



# Inner Layer

- Material: Crosslinked Low Density Polyethylene (XL-LDPE)
- Insulating Layer
  - Contributes to the high impulse strength of the covering, which will protect the conductor from phase-to-phase and phase-to-ground contact
- Crosslinking will allow the material to retain its strength and shape even when heated

# Outer Layer

- Material: Crosslinked High Density Polyethylene (XL-HDPE)
- Insulating Layer
  - Contributes to the high impulse strength of the covering, which will protect the conductor from phase-to-phase and phase-to-ground contact
- Abrasion and Impact Resistant
- Environmental Stress-Crack Resistant
- Track Resistant
- UV Resistant
- Crosslinking (XL) will allow the material to retain its strength and shape even when heated
- HDPE uses Titanium Dioxide as the most effective UV inhibitor, and providing the best track resistant

# Temperature Rating

- Normal Operation: 90°C
- Emergency Operation: 130°C
- Short Circuit Operation: 250°C

# Covered Conductor vs. Bare Comparison

- ACSR Covered Conductor

Conductor Size (AWG)	Conductor Type (Stranding)	Cover Type	Weight (lb/ft)	Overall Diameter (in)	Ampacity per Conductor/ (Amps)
<b>1/0</b>	ACSR (6x1)	XL-HDPE (165 mils)	0.277	0.728	271
<b>336.4</b>	ACSR (18x1)	XL-HDPE (165 mils)	0.564	1.014	550
<b>653.9</b>	ACSR (18x3)	XL-HDPE (180 mils)	0.973	1.313	835

- ACSR Bare

Conductor Size (AWG)	Conductor Type (Stranding)	Cover Type	Weight (lb/ft)	Overall Diameter (in)	Ampacity per Conductor/ (Amps)
<b>1/0</b>	ACSR (6x1)	N/A	0.146	0.398	280
<b>336.4</b>	ACSR (18x1)	N/A	0.365	0.684	605
<b>653.9</b>	ACSR (18x3)	N/A	0.677	0.953	920

# Covered Conductor vs. Bare Comparison

- Copper Covered Conductor

Conductor Size (AWG)	Conductor Type (Stranding)	Cover Type	Weight (lb/ft)	Overall Diameter (in)	Ampacity per Conductor/ (Amps)
#2	HDCU (7)	XL-HDPE (165 mils)	0.316	0.622	240
2/0	HDCU (7)	XL-HDPE (165 mils)	0.569	0.744	367
4/0	HDCU (7)	XL-HDPE (165 mils)	0.845	0.852	488

- Copper Bare Conductor

Conductor Size (AWG)	Conductor Type (Stranding)	Cover Type	Weight (lb/ft)	Overall Diameter (in)	Ampacity per Conductor/ (Amps)
#2	HDCU (7)	N/A	0.205	0.292	260
2/0	HDCU (7)	N/A	0.411	0.414	405
4/0	HDCU (7)	N/A	0.653	0.522	540

### 3. Contact with Foreign Object

This section demonstrates how Covered Conduct reduces ignition risks during contact with foreign object or other conductor by performing a complex engineering analysis and testing impacts of contact on Covered Conductor

# Contact with Foreign Object

- Covered conductors will prevent incidental contacts that cause phase-to-phase and phase-to-ground faults caused by:
  - Vegetation/Palm fronds
  - Conductor slapping
  - Wildlife
  - Metallic Balloons
- Analysis of computer modeled scenarios and field testing supports that covered conductor will prevent faults caused by incidental contact.

# Contact with Foreign Object Using Computer Modeling & Simulation

- An SCE study analyzed the effectiveness of the covering in preventing phase-to-phase faults due to incidental contact
- The study also analyzed the energy absorbed by the foreign object when contact with two covered conductor is significant low and not sufficient to start a fire.
- Scenarios Modeled in computer models using two complex electric power engineering program tools (PSCAD and CDEGS):
  - Tree/Vegetation phase-to-phase contact
  - Conductor Slapping
  - Wildlife phase-to-phase contact
  - Metallic Balloon phase-to-phase contact



# Example of Computer Modeling & Simulation Results for Tree Contact (CDEGS)

## Case 1: Tree on Two Bare Conductors

Maximum Current through object: **2.7 A**

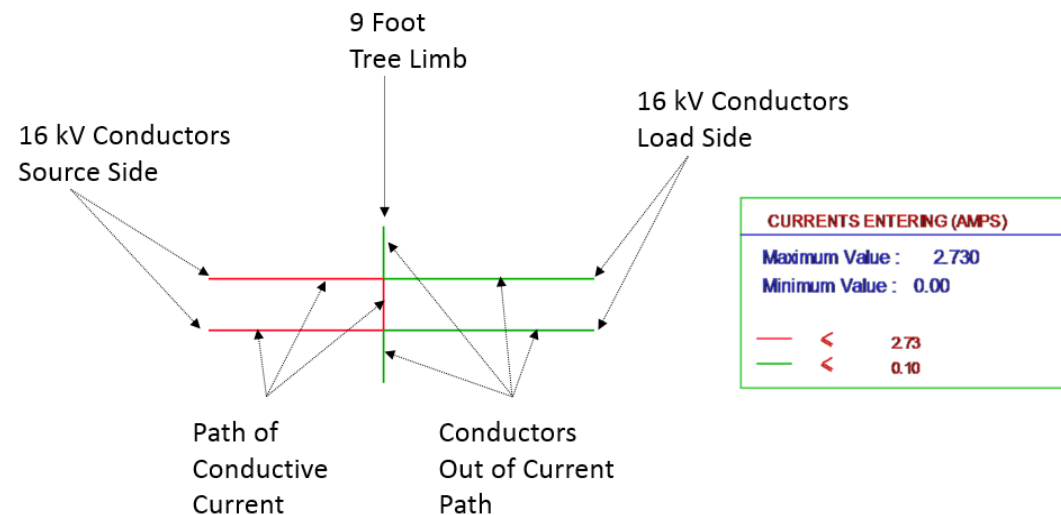

## Case 2: Tree on Two Covered Conductors

Maximum Current through object **0.04 mA**

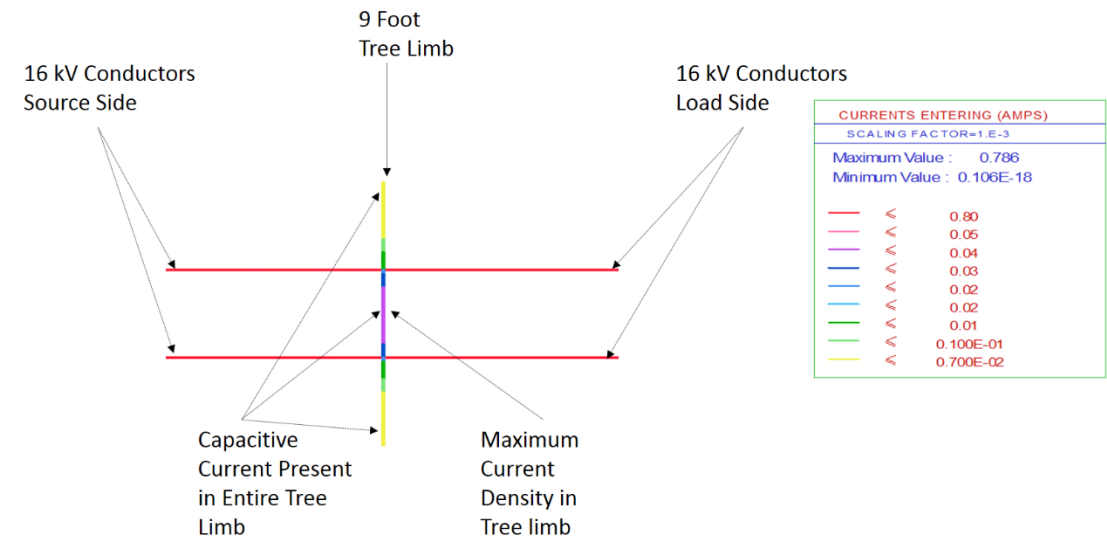

# Study Conclusion

- The analysis concluded that a foreign object contact with covered conductors will not cause a fault
- The results showed that covered conductors reduce the energy from tens of thousands of watts to well under one milliwatt.
- This reduction is expected to be sufficient to prevent ignition

Simulation Method	Conductor Type	Current in Branch	Resistance of Branch	Power into Branch
PSCAD	Bare Conductor	2800 mA	5800 $\Omega$	45,472 W
	Covered Conductor	0.18 mA	5800 $\Omega$	0.00019 W
CDEGS	Bare Conductor	2730 mA	5800 $\Omega$	43,227 W
	Covered Conductor	0.04 mA	5800 $\Omega$	0.00001 W

# Field Testing

- Field testing was performed at SCE' EDEF Test Facility in Westminster to validate the computer model study
- Tests performed for contact with covered conductors only
- No tests performed for contact with bare conductors, because this information is well studied by the industry
- Scenarios tested:
  - Tree/Vegetation phase-to-phase contact
  - Conductor Slapping
  - Wildlife phase-to-phase contact
  - Metallic Balloon phase-to-phase contact

# Palm Frond Contact

- Energized at 12 kV
- Observations
  - No arcing
  - No damage to the covered conductor
  - No damage to the palm frond





# Tree Branch contact

- Energized at 12 kV
- Observations
  - No arcing
  - No damage to the covered conductor
  - No damage to the tree branch





# Conductor Slapping

- Energized at 12 kV
- Observations
  - No arcing
  - No damage to both covered conductors

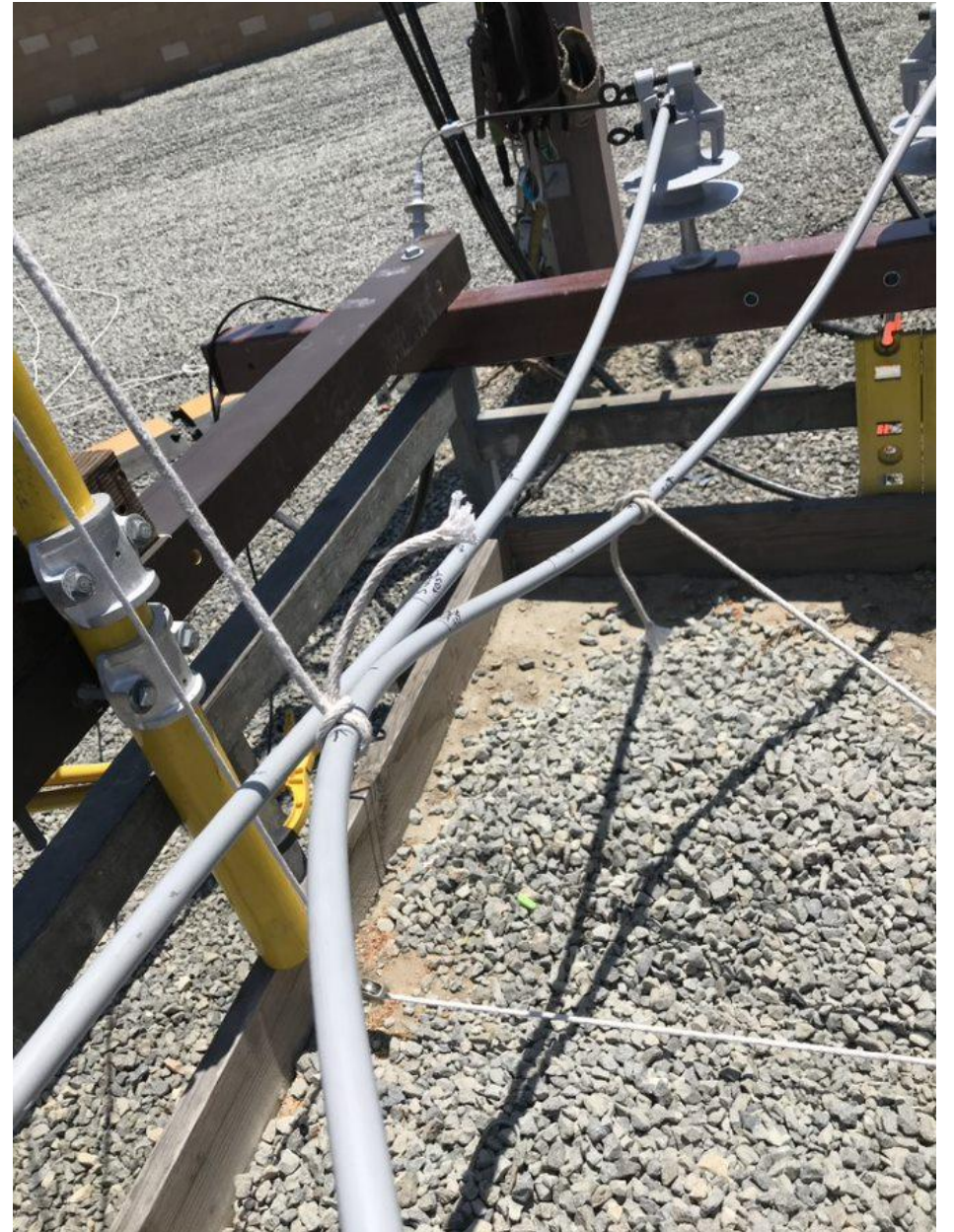



# Wildlife Contact

- 700  $\Omega$  resistor simulated animal contact
- Energized at 12 kV
- Observations
  - No arcing
  - No damage to the covered conductor
  - No damage to resistor





# Metallic Balloon Contact

- Energized at 12 kV
- Observations
  - No arcing
  - No damage to the covered conductor
  - No damage to the metallic balloon





## Field Test Conclusion

- Field testing validated that covered conductor will prevent faults and reduce the chance of ignition due to incidental contact

## 4. Wildfire Mitigation Effectiveness

This section illustrates the analysis of the fire mitigation effectiveness of covered conductors.

# Fault to Fire Analysis

- Initial studies analyzed fault types associated with High Fire Risk Areas and fires produced
- Historical Ignition Source Distribution

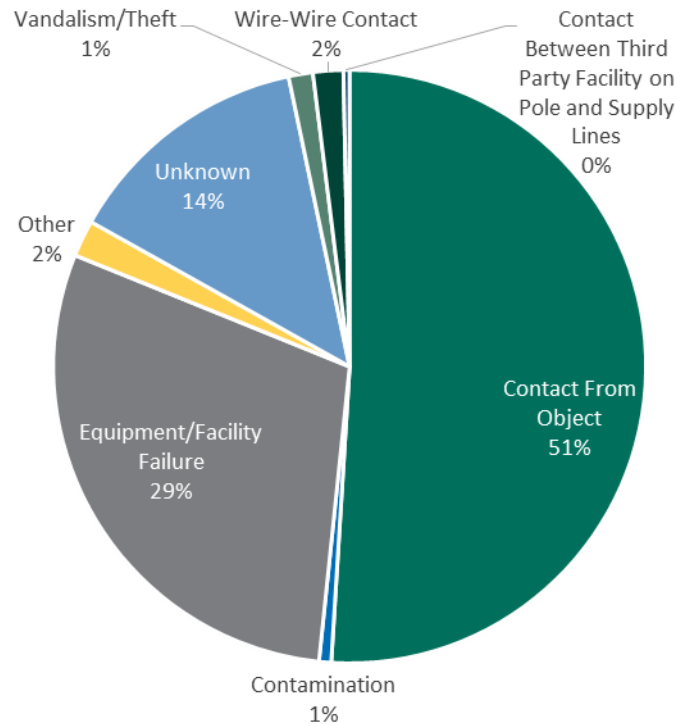

# System Level Risk Distribution

- A ignition risk percentage was tied to each fault type, based on historical data of fires produced by each fault

	"Frequency of Fault"	"Likelihood it leads to a Fire"	"Fires Produced"	"Normalizing for Total Wildfire Risk"	
Fault Type	Annual TEF	CP	Annual Fires		Annual CRR
<b>Contact From Object</b>	<b>895</b>	<b>2.6%</b>	<b>23.3</b>	<b>53%</b>	<b>5,303,030</b>
Animal	250	2.0%	5.0	11%	1,136,364
Balloon	152	3.1%	4.7	11%	1,060,606
Other	48	6.9%	3.3	8%	757,576
Vegetation	238	3.1%	7.3	17%	1,666,667
Vehicle Hit	207	1.5%	3.0	7%	681,818
<b>Equipment/Facility Failure</b>	<b>1,354</b>	<b>1.0%</b>	<b>13.3</b>	<b>30%</b>	<b>3,030,303</b>
Capacitor Bank	8	8.0%	0.7	2%	151,515
Conductor/Wire	145	2.8%	4.0	9%	909,091
Crossarm	39	0.8%	0.3	1%	75,758
Fuse/BLF/Cutout	98	0.3%	0.3	1%	75,758
Insulator	24	7.0%	1.7	4%	378,788
Other	111	2.4%	2.7	6%	606,061
Splice/Connector/Tap	138	1.9%	2.7	6%	606,061
Transformer	791	0.1%	1.0	2%	227,273
<b>Other</b>	<b>571</b>	<b>1.3%</b>	<b>7.3</b>	<b>17%</b>	<b>1,666,667</b>
<b>Total</b>	<b>2,819</b>	<b>1.6%</b>	<b>44.0</b>	<b>100%</b>	<b>10,000,000</b>

# Covered Conductor Ignition Risk Mitigation

- Covered Conductor was found to be effective against Contact from Object faults, such as:
  - Animal
  - Balloon
  - Vegetation
  - Other
- Covered Conductor was found to be effective against some overhead equipment faults due to:
  - Conductor/Wire
  - Splice/Connector/Tap
- Overall, mitigation effectiveness of covered conductor was found to be 60%

	Covered Conductor			
Fault Type	Mitigated Events	Equivalent Fires	Mitigation Effectiveness	MRR
<b>Contact From Object</b>	<b>677</b>	<b>19.5</b>	<b>84%</b>	<b>4,442,340</b>
Animal	250	5.0	100%	1,136,364
Balloon	152	4.7	100%	1,060,606
Other	37	2.5	76%	578,704
Vegetation	238	7.3	100%	1,666,667
Vehicle Hit	0	0.0	0%	0
<b>Equipment/Facility Failure</b>	<b>283</b>	<b>6.7</b>	<b>50%</b>	<b>1,515,152</b>
Capacitor Bank	0	0.0	0%	0
Conductor/Wire	145	4.0	100%	909,091
Crossarm	0	0.0	0%	0
Fuse/BLF/Cutout	0	0.0	0%	0
Insulator	0	0.0	0%	0
Other	0	0.0	0%	0
Splice/Connector/Tap	138	2.7	100%	606,061
Transformer	0	0.0	0%	0
<b>Other</b>	<b>0</b>	<b>0.0</b>	<b>0%</b>	<b>0</b>
<b>Total</b>	<b>960</b>	<b>26.2</b>	<b>60%</b>	<b>5,957,492</b>

## 5. Alternatives Comparison

This section describes the alternatives considered and provides a comparison on their fire mitigation effectiveness and cost.

# Alternatives Considered

- Wildfire Mitigation Options
  - Covered Conductor
    - Replace existing conductor with new, appropriately sized, covered conductor
  - Bare Conductor
    - Replace existing conductor with new, appropriately sized, bare conductor
  - Underground Relocation
    - Relocate existing overhead primary voltages to underground

# Alternatives Mitigation Effectiveness Analysis

- Based on input from Distribution / Apparatus Engineering, a mitigation is assumed to have either 0% (i.e. none) or 100% (i.e. complete) effectiveness against a particular subset of faults within ODRM

	ODRM Cause Code	Covered Conductor Effective?	Bare Conductor Effective?	Undergrounding Effective? <sup>1</sup>
Contact From Object	Animal	Yes	No	Yes
	Balloon	Yes	No	Yes
	Foreign Material; Ice/Snow	Partial (Yes for 'Foreign Material')	No	Yes
	Vegetation Blown; Vegetation Overgrown	Yes	No	Yes
	Vehicle Hit	No	No	Yes
Equipment / Facility Failure	Transformer	No	No	Yes
	Conductor / Wire	Yes	Yes	Yes
	Splice / Connector / Tap	Yes	Yes	Yes
	Fuse / BLF / Cutout	No	No	Yes
	Lightning Arrestor	No	No	Yes
	Crossarm	No	No	Yes
	Pothead	No	No	Yes
	Insulator	No	No	Yes
	Switch / Disconnect AR	No	No	Yes

1. Undergrounding Effectiveness shown only include the mitigation of CFO faults and OH Equipment/Facility Failures, and does not include the additional risk of undergrounding (vault-lid ejection, UG cable and equipment failures, etc.)



# Mitigation Effectiveness Comparison

- The following mitigation effectiveness values were assigned to each alternative:

<b>Alternative</b>	<b>Mitigation Effectiveness</b>
Covered Conductor	60%
Bare Wire	15%
Underground	100%

# Cost Comparison

- The following Unit Cost values were assigned to each alternative:

<b>Mitigation Option</b>	<b>Relative Mitigation Effectiveness Factor</b>	<b>Cost per Mile (\$ million)</b>	<b>Mitigation-Cost Ratio</b>
Re-conductor - Bare	0.15	0.30	0.50
Re-conductor - Covered	0.60	0.43	1.40
Underground Conversion	1.00	3.00	0.33

# Conclusion

- While re-conductoring with bare conductor would have lower cost, and underground conversion would have greater benefit, re-conductoring with covered conductor has greater overall value.
- A dollar spent re-conductoring with covered conductor provides nearly three times as much value in wildfire risk mitigation as dollar spent re-conductoring with bare conductor
- A dollar spent re-conductoring with covered conductor provides over four times as much value in wildfire risk mitigation as dollar spent on underground conversion.

## 6. Safety Advantages

# Safety

- In the case of a downed conductor, covered conductors will provide a safety advantage over bare wire.
- The covering on the covered conductor will reduce the charging current enough to result in, at most, a slight shock during human contact while contact with bare wire will result in electrocution.
- While evidence of a reduced charging current is available in multiple industry papers, SCE has sponsored a test with NEETRAC on covered conductor touch current to verify this data

# Effects of Electrical Current

- Effects of Electrical Current on the Human Body

Current	Effect
<b>Below 1 mA</b>	Generally not Perceptible
<b>1 mA</b>	Faint Tingle
<b>5 mA</b>	Slight Shock; Not painful but disturbing. Average individual can let go
<b>6-25 mA (women) 9-30 mA (men)</b>	Painful shock, loss of muscular control. The freezing current or "let-go" range. Individual cannot let go, but can be thrown away from the circuit if extensor muscles are stimulated
<b>50-150 mA</b>	Extreme pain, respiratory arrest (breathing stops), severe muscular contractions. Death is possible



# NEETRAC Testing – Energized Downed Conductor

- The following are test cases of energized wire down scenarios that were simulated and empirically tested by NEETRAC
  - Person holding broken **covered conductor** on **line side**
  - Person holding broken **covered conductor** on **load side**
  - Person holding broken **bare conductor** on **line side**
  - Person holding broken **bare conductor** on **load side**

\*Note that bare conductor test cases were not performed in the laboratory.

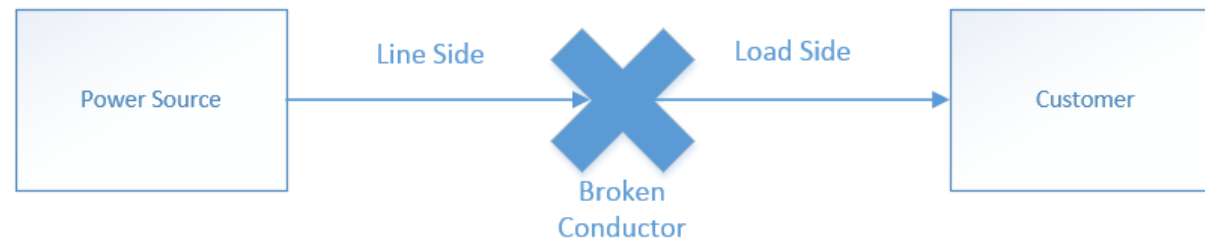

# NEETRAC Testing

- Test Information:
  - Conductor: 1/0 Covered Conductor
  - Source: 12.447 kV
  - Test Results: Human contact current measured

	Covered Conductor		Bare Conductor
	Simulation Results (Theoretical Value)	Lab Test Results (Actual Values)	Simulation Results (Theoretical Value)
Line Side	0.220 mA	0.227 mA	5,300 mA
Load Side	0.218 mA	0.227 mA	34.2 mA

- Conclusion:
  - Covered Conductor Touch Current: Generally Not Perceptible
  - Bare Conductor Touch Current: Electrocution
  - Overall, covered conductors can potentially provide public safety benefits during wire down events

# Chapter II

## Life Expectancy

Energy for What's Ahead<sup>SM</sup>



# 1. Expected Service Life

This section describes the life expectancy of covered conductors, the basis for the projection, and factors that influence service life.

# Service Life

- SCE expects covered conductors to have a service life of **45 years**
- Conclusion of 45 years is based on
  - Manufacturer response
  - Historical Records
  - SCE experience with similar products

# Manufacturer Survey

- Manufacturer consensus is that the covered conductor service life is expected to be 40 years minimum

<b>Surveyed Questions</b>	<b>Supplier 1</b>	<b>Supplier 2</b>	<b>Supplier 3</b>
<b>1. What is the expected service life of the covering?</b>	Minimum of 40 years, and probably 60 plus years	40 years	40 years
<b>2. What is the expected service life of the conductor?</b>	Useful service life in excess of 80 years	40 years	40 years
<b>3. What is the expected service life of the covered conductor as a whole?</b>	Excess of 67 years	40 years	40 years

# Basis for Expected Service Life

- Advancement of compound technology and the upgrade of manufacturing equipment
- Known service life of XLPE is 40 years minimum
- Conformance to and successful passing of qualification tests ensures life expectancy
- Historical records with systems installed since 1951 are still in operation and performing as designed 67 years ago



# Factors that Influence Service Life

- Conductor Temperature
  - Operating at extreme temperature is known to damage the conductor and/or covering
- Extreme contamination
- Severe UV exposure
- Installation methods and condition
- Type and Quality of Accessories

# Qualification Testing

- SCE requires the following tests to ensure the longevity of the conductor
  - UV Testing
  - Environmental Stress Cracking
  - Track Resistance
  - Maximum Dielectric Constant
- Passing qualification tests ensures that the covered conductor deployed in SCE facilities meet industry standard and are high quality
- Passing ensures that the covering can perform as intended for a 45 year operating life

## 2. UV Resistance

This section describes the requirements of the UV resistance testing.

# Sunlight (UV) Resistance Testing

- SCE requires conformance to ICEA S-121-733-2016 Sunlight Resistance (UV) Testing
- Testing will accurately predict, on an accelerated basis, the effect of sunlight
- UV testing will involve inducing property changes associated with the end use conditions, including the effects of sunlight, moisture, and heat. Testing requires specimens to be exposed to xenon-arc radiation and water-spray exposure.
- The exposure time is 720 hours with a radiation level of 0.35 Watt/meter. This radiation level was chosen based on the most extreme summer weather similar to the state of Florida, which is always equal to or greater in UV intensity than in Southern California.
- The covering is considered sunlight resistant if the original to aged tensile and elongation ratio 80% or greater after the 720 hours of exposure. Additionally, because the covering is grey, the amount of UV absorption will be limited.

# Significance

- Testing ensures that the strength of the covering is still at least 80% of the original strength before accelerated UV exposure
- Overall, UV testing requirement ensures the longevity of the covering

## 3. Environmental Stress-Cracking

This section describes the requirements of Environmental Stress-Cracking Testing.

# Definitions

- Stress-Crack – An external or internal rupture in a plastic caused by tensile stresses less than its short-time mechanical strength

# Environmental Stress-Cracking Testing

- ICEA S-121-733-2016 does not require Environmental Stress-Cracking Resistance for 90°C rated covered conductor because the covering material is inherently resistant to Environmental Stress-Cracking
- Environmental Stress-Cracking is the development of cracks in the material due to low tensile stress and environmental conditions. Under certain conditions of stress with the presence of contaminants like soaps, wetting agents, oils, and detergents, ethylene material may exhibit mechanical failure by cracking.



# Significance

- Having a 90°C Rated covered conductor means that the covering will be inherently resistant to cracking under conditions of stress and in the presence of contaminants

## 4. Track Resistance

This section describes the requirements of the track resistance testing.

# Definitions

- Electrical Erosion – The progressive wearing away of electrical insulation by the action of electrical discharges
- Track – A partially conducting path of localized deterioration on the surface of an insulating material
- Tracking – The process that produces tracks as a result of the action of electrical discharges on or close to the insulation surface
- Tracking Resistance – A quantitative expression of the voltage and the time required to develop a track under specified conditions

# Track Resistance Testing

- SCE requires conformance to ICEA S-121-733-2016 Track Resistant Testing
- Track resistance testing will evaluate the tracking and erosion resistance of the covering and its effects upon the insulation.
- During this test, the covering is exposed to a conducting liquid contaminant at an optimum rate, in a manner that allows continuous electrical discharge to be maintained.
- The effects are similar to those that may occur in service under the influence of dirt combined with moisture condensed from the atmosphere.
- Producing continuous surface discharge with controlled energy will mimic long-term exposure in the field in an accelerated time frame.
- For the sample to pass, the time to track one inch at 2.5 kV must be a minimum of 1000 minutes.

# Significance

- Testing ensures that the covering is track resistance
- Track resistance properties will ensure insulation that electrical charges will not erode the insulation over time
- Overall, testing requirement ensures the longevity of the covering

## 5. Maximum Dielectric Constant

This section describes the maximum dielectric constant requirements

# Definitions

- Dielectric Constant: a quantity measuring the ability of a substance to store electrical energy in an electric field
- Dielectric Strength: the maximum electric field that a pure material can withstand under ideal conditions without breaking down

# Maximum Dielectric Constant

- The maximum dielectric constant must be 3.5, per ICEA standards
- The lower the dielectric constant, the higher the dielectric strength.



# Significance

- Ensuring that the dielectric constant meets the requirements certifies that the insulation strength of the covering is acceptable and the covered conductor will perform as designed.

# 6. Production Testing

This section describes production testing requirements.

# Production Testing

- SCE requires manufacturers to perform routine production testing
  - DC Resistance
    - The DC resistance on the conductor must not exceed 102% of the maximum allowable value
  - Unaged and Aged Tensile and Elongation
    - Tensile elongation is the stretching that a material undergoes. The point of rupture must be greater than 1800 psi for unaged samples. Samples are aged at 121°C for 168 hours. Aged samples must rupture at a minimum of 75% of the unaged value. This test validates the mechanical properties of the covering
  - Hot Creep
    - Hot creep tests validates that the covering is crosslinked, making it a thermoset. Thermosets can withstand higher temperatures and are less likely to deform at high temperatures.
  - Spark Test
    - Spark tests validates the integrity of the insulation. An electrical cloud is generated around the cable. Any pinholes or faults in the insulation will cause a grounding of the electrical field and this flow of current will register a defect in the insulation.
- Passing routine production tests ensures that the covered conductor deployed in SCE facilities meet industry standard and are high quality
- Passing ensures that the covering can perform as intended for a 45 year operating life

## 7. Covered Conductor Failure Mode

This section articulates the possible failure modes and provides a high-level analysis how these impact on Covered Conductor at SCE, and finally what SCE has done to address these failure modes

# Known Failure Modes

- Covered conductor could have burn down if not adequately designed or installed
- The following known issues are addressed either by design criteria or installation guideline
  - Electrical tracking on surface of covers
  - Arc generated from lightning strikes
  - Aeolian (Wind-Induced) Vibration
  - Premature Insulation Breakdown

# Mitigating Against Electrical Tracking on Surface of Covers

- Electrical tracking occurs when carbon pathways (tracks) form on the surface of an insulating material, which could lead to breakdown
- SCE will only procure CC that has completed extensive qualification testing to industry standards (UV Resistance, Environmental Cracking, and Track Resistance)
- Early material that suffer from tracking issues are crosslinked polyethylene with high carbon content for UV inhibiting purposes
  - SCE specified material using cross-linked high density polyethylene with little carbon black. Titanium Dioxide is used as a UV inhibitor.
- Early design of CC specify thin layers of insulation (less than 100 mils)
  - Covered conductor SCE will used has 150 mils of insulation

# Arc Generated During Lightning Strikes

- During lightning strikes, an arc could form on the transition from covered to bare conductor, or where there are stripped or open point in the covered conductor
- Direct lightning strike on covered conductor would be more damaging than bare conductor because lightning moves more freely on bare conductors (to look for a path to earth)
- However, SCE is well prepared to mitigate this known issue for several reasons:
  1. SCE service territory is considered low lightning area
  2. Covered conductor is generally less “attractive” to lightning than bare conductor (insulating materials reduces electric field on the surface of covered conductor)
  3. SCE uses the most effective mitigation tool for lightning strikes
- Mitigating Lightning Failure
  1. Industry uses Arc Protection devices (APD’s), Power Arc Devices (PAD’s) and Lightning Arrestors (LA’s) for mitigating lightning strike failures
  2. Lightning Arrestor is the most well-built and effective device of all three
  3. SCE uses Lightning Arrestors and bolster the standards for covered conductor systems to be treated as high lightning area
  4. SCE’s high lightning standards require Lightning Arrestors to be installed in all equipment poles (all transformer sizes, capacitor, RAR, switch, voltage regulator, etc.)
  5. SCE standards requires Lightning Arrestors to be installed in covered conductor to underground transitions
  6. SCE will minimize stripping and removal of the covering
  7. SCE standards require stripped or uncovered portions will be covered (i.e. splice)

**CONCLUSION: SCE is well positioned for protecting covered conductors from lightning because direct strikes on covered conductors are less likely at SCE’s territory, but if it happens, damage due to lightning may be mitigated by Lightning Arrestors, i.e. direct to ground instead of stuck on one covered location, or covered to bare transition or flash over to other phases.**

# Aeolian (Wind Induced) Vibration

- Wind induced vibration of conductors could lead to fatigue failure of the conductor (similar to bending a piece of wire back and forward until it break) High conductor tensions lead to Aeolian vibration issues
- Mitigating Aeolian Vibration
  - SCE developed proper sag and tension values for covered conductor
  - SCE's tension limits are in line with Northeast Utilities that have an 80% covered conductor system.
  - The Northeast utilities indicated that they have not experienced problems due to Aeolian vibration



# Premature Insulation Breakdown

- Wear and tear could lead to premature insulation breakdown
  - Insulation breakdown will equate effectiveness of covered conductor to bare
  - Result from improper installation or constant abrasion from vegetation
- Mitigating premature insulation breakdown
  - Outer covering is a high density material, and is resistant to incidental abrasion
  - Discussion with other utilities indicated that older covered conductor design performed as intended even after 50 years
  - Construction standard requires care during installation and handling of the covered conductor

# Learning from Past Experience

- SCE has performed literature research, talked to industry experts, visited utilities and suppliers, and employed consultants to inform the design and installation of covered conductor to withstand early known issues
- Based on past performance in various utilities and the robustness of the current covered conductor design, Engineering fully expect the covered conductor to perform for at least 45 years without issues

# Chapter III

## Industry Benchmarking and Research

Energy for What's Ahead<sup>SM</sup>



# 1. Benchmarking

# Utility Benchmark Questionnaire

- Sent out survey questionnaire to utilities to learn about covered conductor standards, application and performance:
  - Seattle City Light (Washington)
  - Puget Sound Energy (Washington)
  - Con Edison (New York)
  - Orange and Rockland Utilities (New York)
- Learned about downed wires with covered conductor
  - In Early 1980s, Con Ed experienced plenty of burn downs
    - Failures were at dead ends and equipment leads
    - Failures were at bare to covered transitions
  - Orange and Rockland found that protective relays will trip during a burn down
- Failure modes of covered conductor
  - Nicked conductor during stripping
  - Prolonged incidental contact (months)
- Cable type and Size
  - Seattle City Light and Puget Sound: 125 mils HDPE
  - Con Edison: 175 mils EPR
  - Orange and Rockland: 40-80 mils XLPE
- Voltage
  - Seattle City Light: 7.2 kV
  - Con Edison:
    - 27 kV – Mostly CC
    - 4-14 kV – CC

# Round Table Benchmark with Northeast Utilities

- Conducted an in-person discussion on covered conductor experience with the Northeast utilities:
  - Hendrix (manufacturer), Liberty Utilities (New Hampshire), Groveland Light (Massachusetts), Holyoke (Massachusetts), Middleton (Massachusetts).
  - Past standards engineer of Eversource attended as well
- Covered Conductor Systems
  - New England overall is approximately 80% Covered Conductor and 20% Bare
- End of life
  - Covered conductor still looks and performs the same after 50+ years of service
- Issues
  - Manufacturing problems due to ring cuts was experienced in the late 70s before cleanrooms
  - Corona is main failure mode (phase to ground through tree), but it takes years to fail
  - None has experienced Aeolian vibration issues
  - None has encountered water ingress
- Lightning
  - Burn down happens at stripped portion
  - Add lightning arrestors at equipment, transitions to bare, and dead-ends
  - Had enough incidents to decide to install lightning arrestors at end of line
  - All advise not to install lightning arrestors at every 1000 ft. Avoid stripping as much as possible.

# Global Research

- Global information was gathered from covered conductor research literature as well as government and utility publications.
- Future Benchmarking Plans:
  - SCE will contact Australian utilities directly to gather more information about their Bushfire Mitigation Plans
  - SCE will conduct a round table discussion with South Korea's utility Korean Electric Power Corporation (KEPCO) to learn more about construction best practices and understand the reasoning behind their deployment of covered conductor.

# Global Research – Australia (Historical Installations)

- Covered Conductor has been used in Australia for over 50 years
- Early installations experienced the following problems:
  - Initial coverings of PVS, HDPE, and nylon gave very limited lifetimes and suffered surface degradation.
  - Initial installations were subject to failure due to lightning damage
- In the late 1980s, Australia reconsidered Covered Conductor for safety considerations (human and wildlife), conductor clashing, tree problems, and bushfire mitigation.
  - However, within 2 years of installation, it was found that the covered conductor was incapable of handling anything more than momentary contact
  - Other problems include severe RF emissions and tracking
- In the mid 2000s research for the Australian Strategic Technology Program illustrated that technological advancements and solutions to historical issues regarding covered conductors exist, which may allow for a widespread adoption of covered conductors in Australia



# Global Research - Australia

- In 2009, the Victorian Bushfires Royal Commission (VBRC), which was established in 2009 by the government after the devastating Black Saturday bushfires, recommended the following:
  - The progressive replacement of all SWER (single-wire earth return) power lines in Victoria with aerial bundled cable, underground cabling or other technology that delivers greatly reduced bushfire risk. The replacement program should be completed in the areas of highest bushfire risk within 10 years and should continue in areas of lower bushfire risk as the lines reach the end of their engineering lives
  - The progressive replacement of all 22-kilovolt distribution feeders with aerial bundled cable, underground cabling or other technology that delivers greatly reduced bushfire risk as the feeders reach the end of their engineering lives. Priority should be given to distribution feeders in the areas of highest bushfire risk.
- Progress of VBRC recommendation implementation:
  - 2010 – Established a Bushfire Powerline Safety Taskforce (BPST) to recommend to the Victorian Government how to maximize the value to Victorians from the VBRC recommendations.
  - 2011 – The Bushfire Powerline Safety Taskforce recommended the following:
    - The BPST recommended to target SWER and 22kV powerlines in the next 10 years
    - The BPST recommended that any new powerlines built in areas targeted for replacement should also be built with underground or covered conductor
    - Estimated a 90% reduction in the likelihood of a bushfire starting by installing covered conductors
    - Recommendations were accepted by the Minister for Energy and Resources on December 29, 2011
    - AUS \$750 million Powerline Bushfire Safety program was announced by the Victorian Government
  - 2012 – Areas of highest bushfire risk for purposes of asset installation were identified and a detailed forward works program was developed
  - 2013 – A brief focusing on the first five years of the program, described in more detail the complexities of delivering the substantial set of reforms and provided concise project planning, management, and delivery structure.
  - 2014 – Installation of first replacement powerline in high bushfire risk areas
  - **2016 – Amendments were made to the Electricity Safety (Bushfire Mitigation) Regulations which specify the use of covered conductors or undergrounding for any new or rebuilt circuits in high bushfire risk areas**
    - **The Victorian Government's Powerline Replacement Fund makes available up to \$200 million to electrical distribution businesses and private land owners to replace bare wire powerlines**

# Global Research – Australia

- Utility Implementations of VBRC Recommendations
  - Ausnet
    - Victorian utilities to use either insulated or covered conductor for any planned conductor replacement of more than 4 spans of 1kV-22kV line (within codified areas)
    - For AusNet, the codified areas included approximately 1,000 miles of bare wire, medium voltage powerlines. **They began replacing line in this area in 2014 relying on an established \$200M Powerline Replacement Fund (PRF)**
    - AusNet is progressively replacing the remaining bare wire in codified areas outside of PRF activities because of the cost associated with insulated/covered conductors
    - **Construction of any new medium voltage electric line that is part of the supply network must use insulated cable or covered conductor**
  - Powercor
    - Per their 2016 Bushfire Mitigation Plan, Powercor is implementing underground cable/overhead covered conductor when construction either 22kV, single wire earth return (SWER) or low voltage assets for all new construction and the same Electrical Safety (Bushfire Mitigation) Regulations listed for AusNet reconductoring activities
- Utilities outside of Victoria
  - Energy Queensland
    - 2017 Summer Preparedness Plans target installation of covered conductor in bushfire risk areas.
  - Essential Energy
    - Bushfire Risk Management Plan (Issue 13, 2017) was provided to meet the objectives and requirements of the NSW Electricity Supply (Safety and Network) Regulation 2014, which includes a provision for the review of equipment types or construction methods known in their operation or design to have bush fire ignition potential and a mitigation strategy in relation to their use
    - Plan calls for use of underground cable and covered conductor on overhead primary, promoting underground or insulated low voltage lines in rural areas, and identifying at-risk private low voltage lines on customer properties and undergrounding or replacing with CCT

# Global Research - Europe

- United Kingdom
  - The UK started installing covered conductors in 1994
  - The typical close spacing and compact construction prompted the first use of covered conductors in the UK
  - As of 2005, UK has installed 9,300 circuit miles of covered conductor
- Finland
  - Finland installed the first installations of covered conductors in Europe.
  - Main impetus for research into covered conductors in the 1970s was the reduction of forest fires caused by trees falling on bare overhead lines.
  - As of 2005, Finland installed approximately 3,100 miles of covered conductor.
  - 60% of new construction and refurbishment schemes use covered conductor
- Sweden
  - Covered Conductor was first introduced in Sweden in 1984.
  - First installation was in a snowy and high wind area to reduce faults due to snow-laden branches resting on the line and wire slapping
  - As of 2005, Sweden installed approximately 2,500 miles of covered conductor
  - 60% of new construction and refurbishment schemes use covered conductor

# Global Research - Asia

- South Korea
  - Extensive CC use by Korea Electric Power Corporation (KEPCO) for 23 years
  - Covered Conductors make up 96% of South Korea's low voltage and medium voltage distribution line
  - Use CC Tested to 25 kV
- Japan
  - Started using covered conductors in 1965
  - Driving force behind CC installation is to reduce the number of accidents and fatalities due to bare OH lines and improve reliability

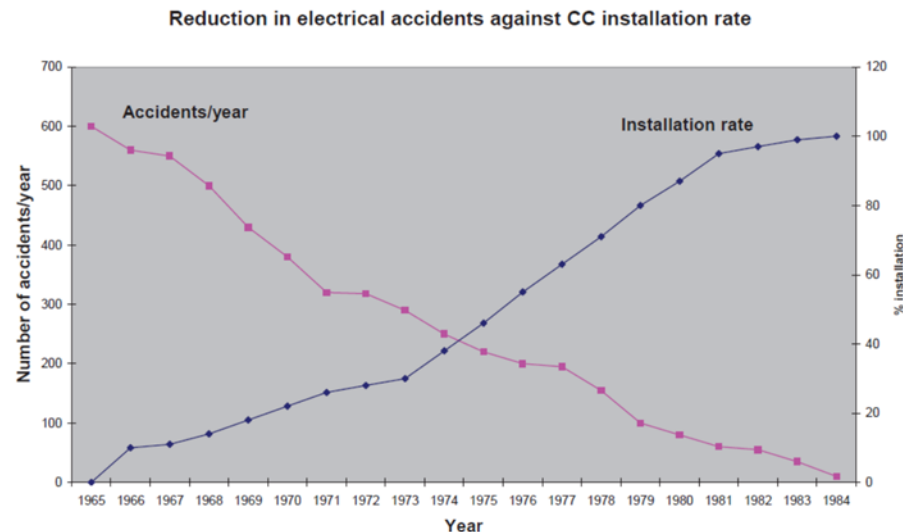

## 2. Industry Surveys

# Background

- SCE requested members of the following groups to participate in a survey about covered conductors
  - Edison Electrical Institute (EEI)
  - Western Underground Committee (WUC)
  - The Association of Edison Illuminating Companies (AEIC)
- A total of 36 utilities participated.

# Summary

- Bare wire is the standard.
  - On average bare wire makes up 88% of a utility's distribution system
- 28% of participants indicated that they use covered conductors on primary distribution lines.
- 33% of participants indicated that they historically used covered conductors, but no longer use them on new installations
- Most utilities indicated that covered conductor is used to prevent vegetation contact
- Most utilities indicated that the benefit of using covered conductor is less contact related faults

# List of Participants

1	AES
2	Alliant Energy
3	Ameren
4	American Electric Power
5	Anonymous Participant
6	CenterPoint Energy
7	City of Banning
8	City of Lodi
9	City of Mesa Energy Resources
10	City of Richland, WA
11	City of Roseville
12	Con Edison
13	Dominion Energy
14	DTE Energy
15	Duke
16	FirstEnergy
17	Florida Power & Light
18	Idaho Power
19	Kansas City Power and Light

20	LADWP
21	LG&E and KU Energy
22	Midwest Energy, Inc.
23	National Grid
24	Northern Indiana Public Service Co.
25	Northwestern Energy
26	Oklahoma Gas & Electric
27	Oncor Electric Delivery
28	Orange & Rockland
29	Puget Sound Energy
30	Sacramento Municipality Utility District
31	Salt River Project
32	Snohomish PUD
33	Southern Company
34	Tampa Electric
35	Tucson Electric Power
36	Westar Energy



# Covered Conductor Usage

- Do you install covered conductor (Tree wire) for your primary (4 kV or higher) distribution lines?

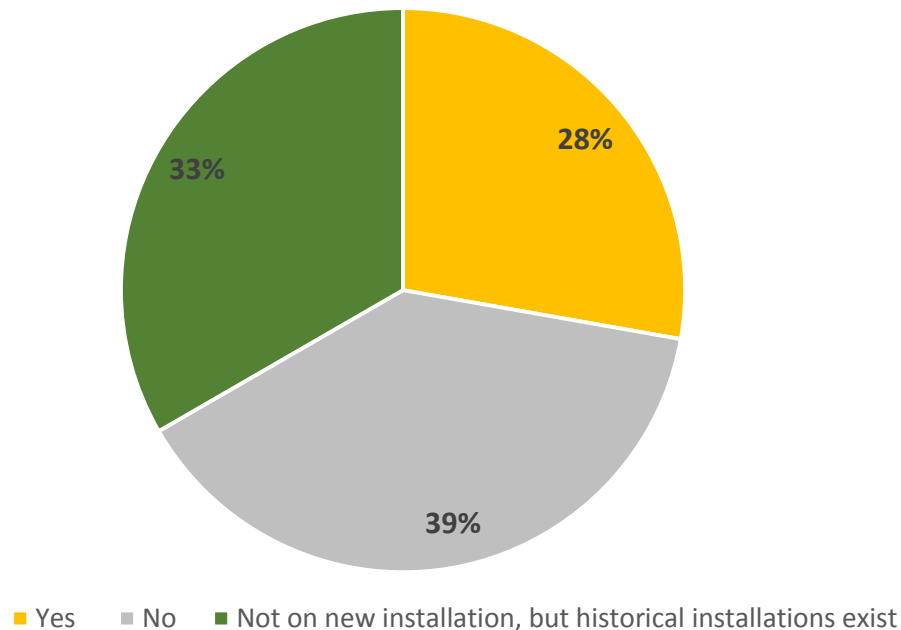

- Do you install covered conductor (tree wire) for your branch line primary distribution wire? (fused, radial, two phases or less)

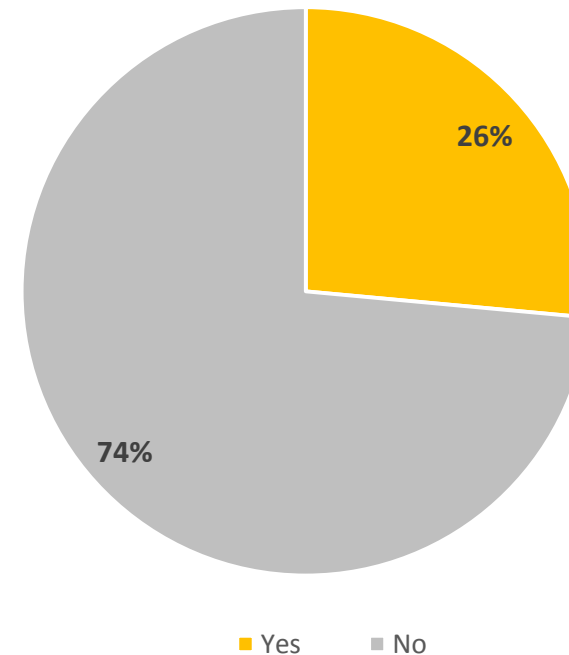

# Reasons for Using Covered Conductor

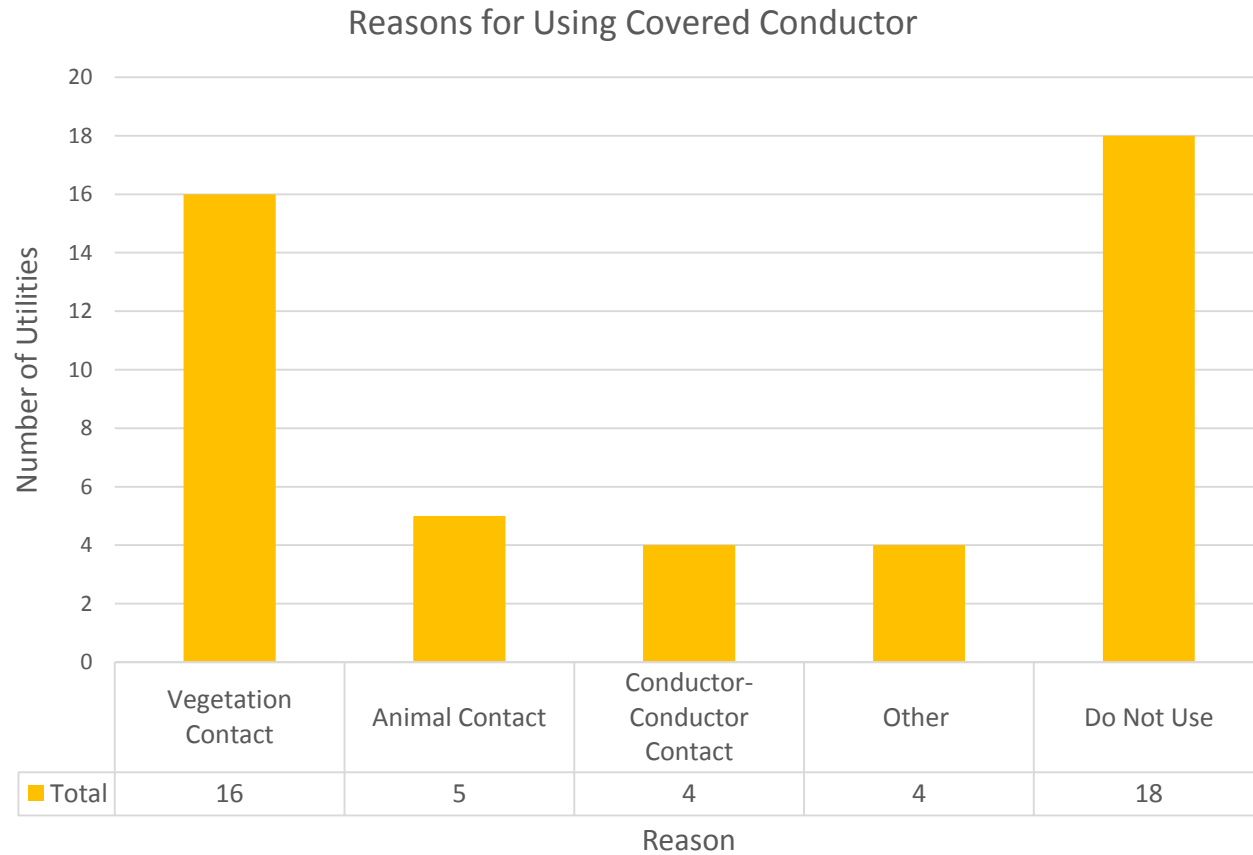

## Other

- Clearance and space management
- Higher density of circuit routing on a single pole

# Types of Overhead Primary Construction Used

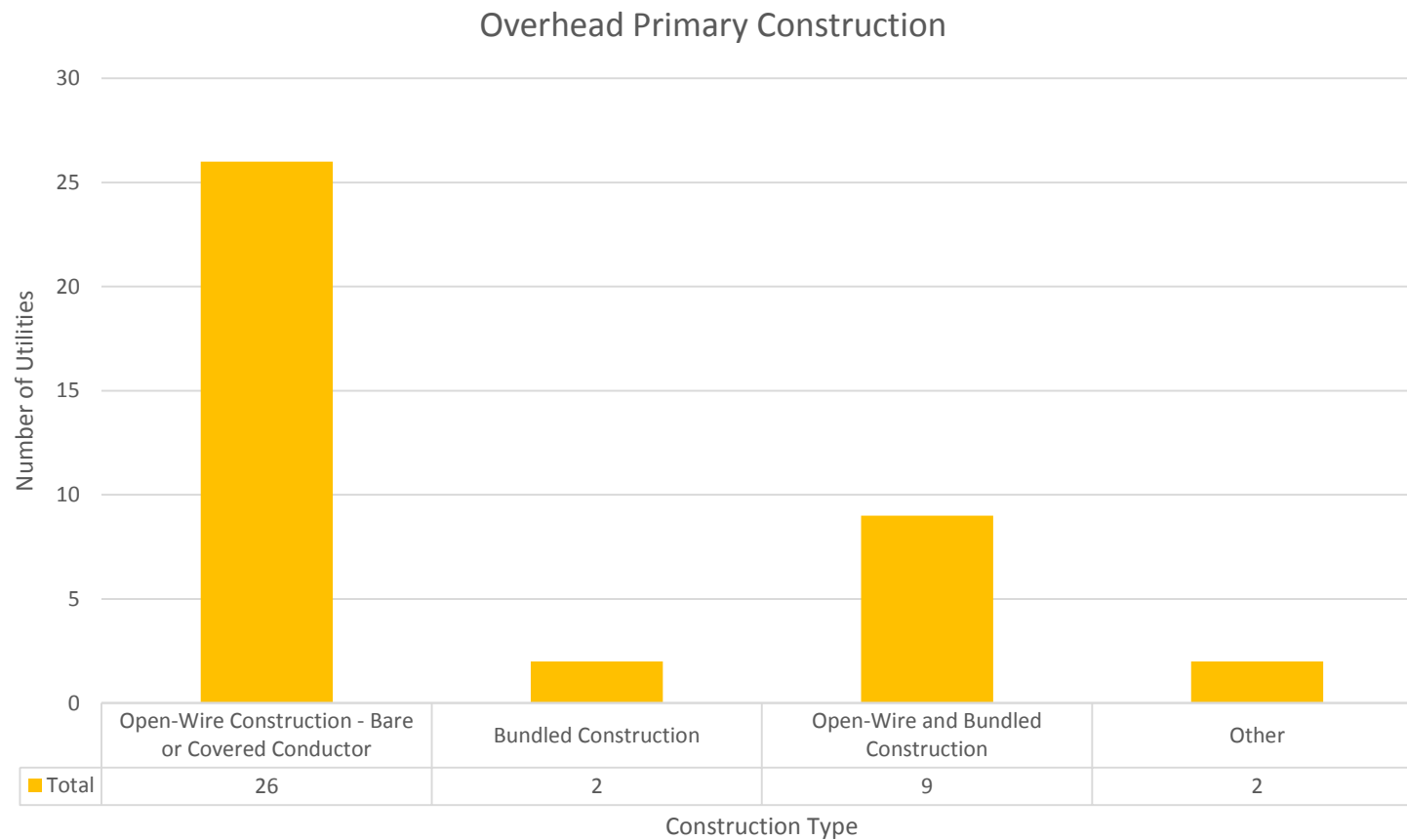

- Other
  - Armless Construction
- Open-wire can mean vertical or horizontal construction

# Construction Criteria

- Utilities typically use bundled construction in limited scenarios, which can include the following:
  - Use in areas in lieu of underground due to difficult trenching conditions
  - Express or dedicated feeders with limited or no taps
  - Limited right of way space
  - Heavily treed areas with tight clearances
  - Multiple circuits on a single pole
  - Storm hardening

# Distribution of Various Wire Types

Average Distribution of Wire Types

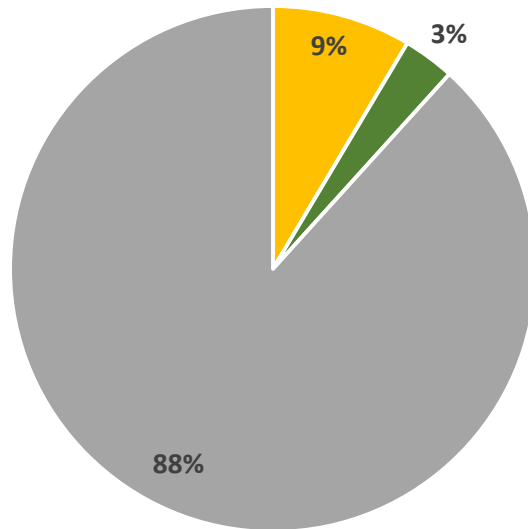

- Covered conductor on cross-arm configuration
- Covered conductor on spacer configuration
- Bare Conductor

- On average, a utility's distribution system is made up of
  - 88% Bare Wire
  - 9% Covered Conductor on cross-arm configuration
  - 3% Covered Conductor on spacer configuration

# Years of Covered Conductor Use

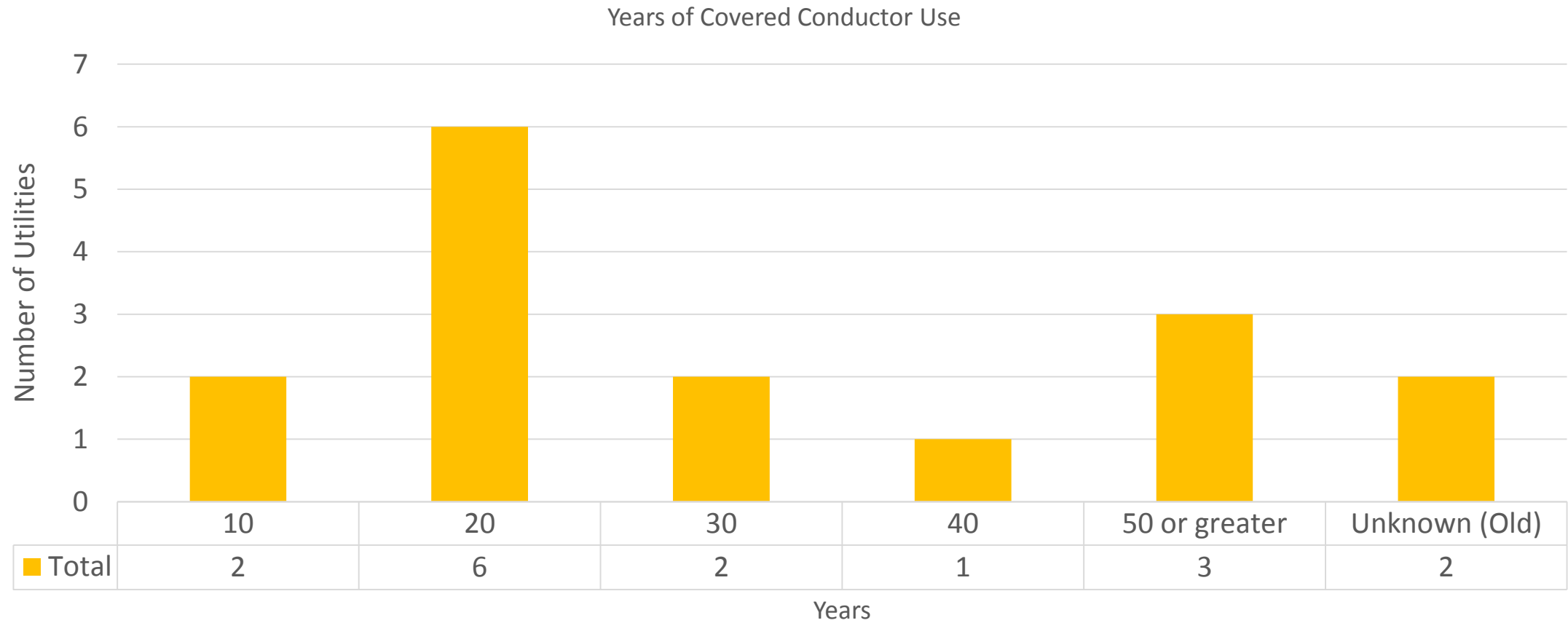

# Covered Conductor Wire Sizes and Layers

Wire Size Used

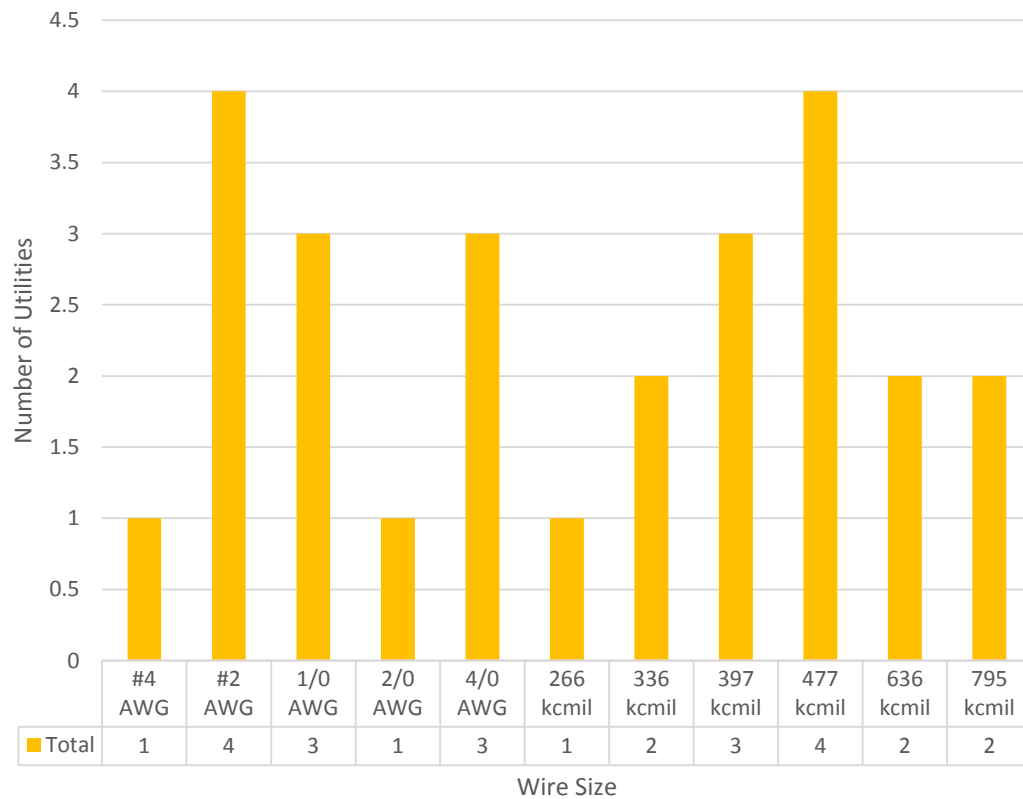

Covered Conductor Layers

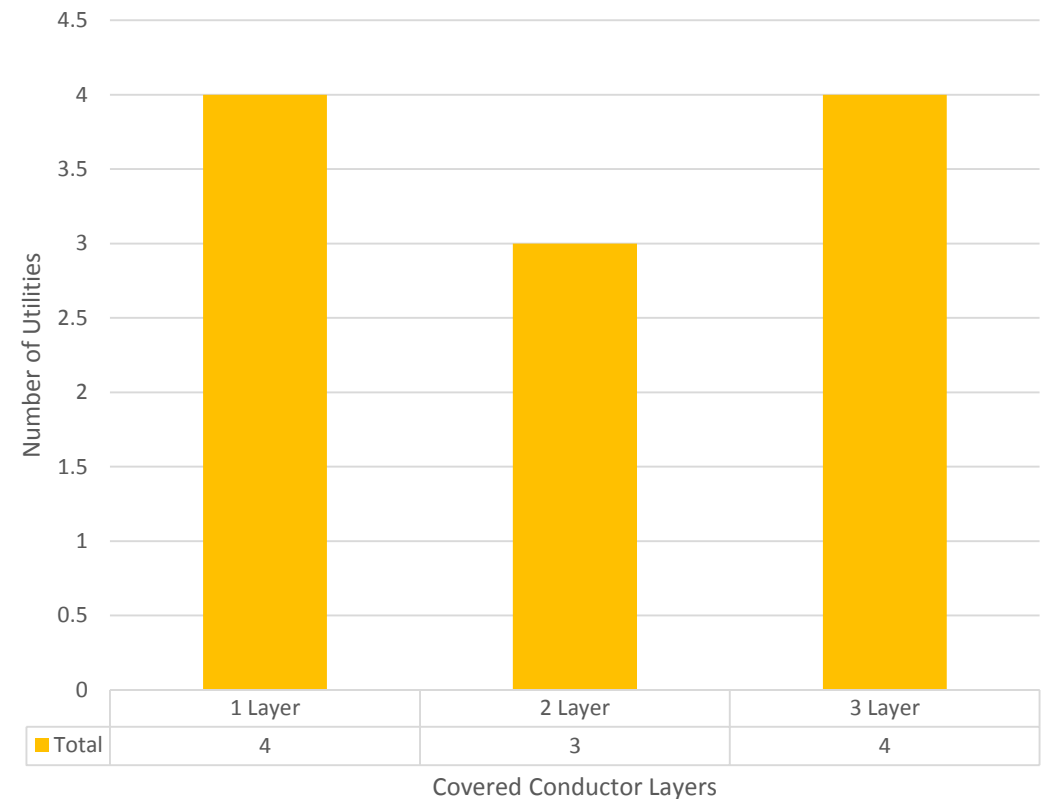

# Re-conductoring Main Line

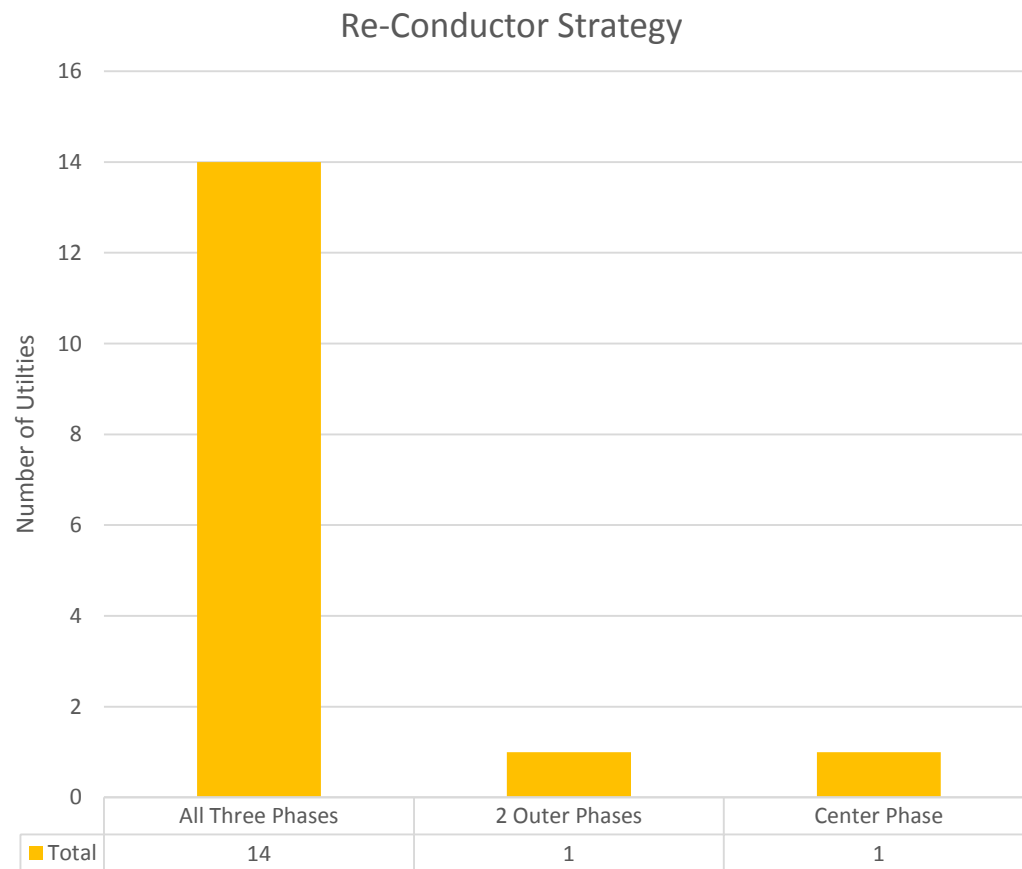

- All utilities indicated that they re-conductor all three phases when moving from bare wire to covered conductor
- One utility indicated that a standard does not exist and therefore performs all three options when re-conductoring to covered conductor:
  - All Three Phases
  - Two Outer Phases Only
  - Center Phase Only



# Benefits Gained with Covered Conductor

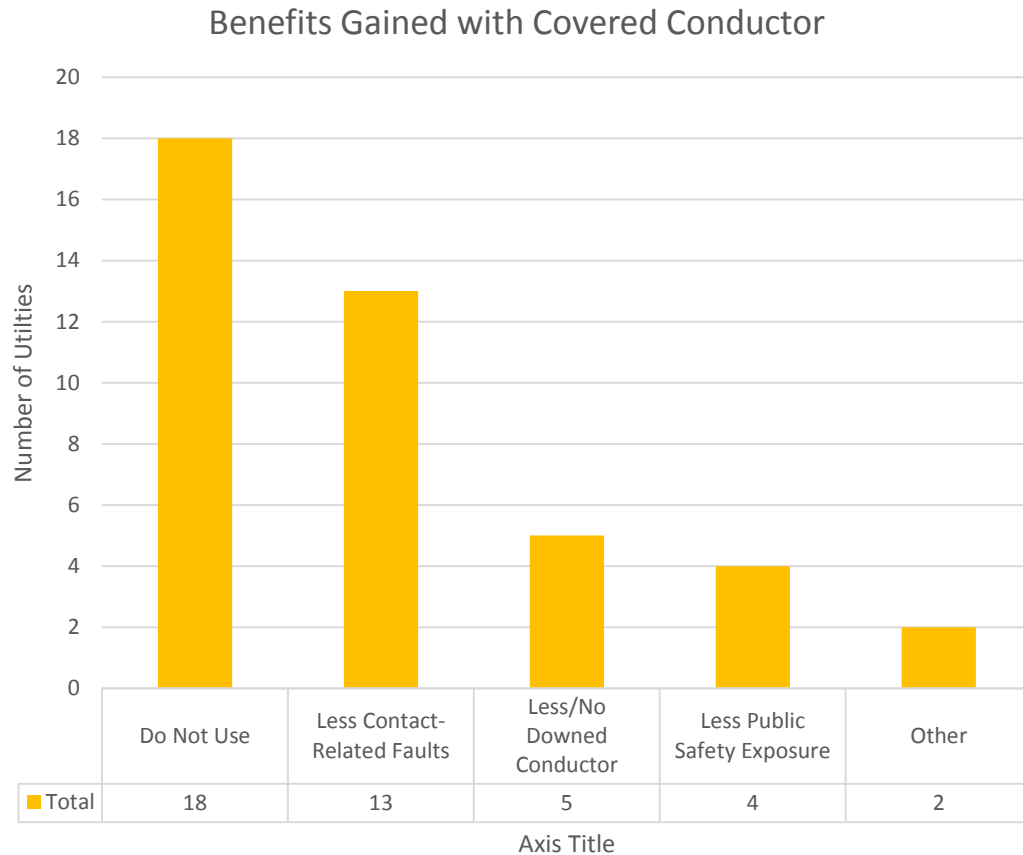

- Other:
  - Utilities that answered “Other” indicated covered conductor caused more problems such as more downed conductor however, this experience is based on historical covered conductor systems (from 20 years ago or more).

### 3. Incorporating Lessons Learned

# Known Challenges

The following challenges associated with covered conductor have been identified via research and benchmarking:

1. Aeolian Vibration
2. Abrasion
3. Electrical Withstand
4. Lightning Protection
5. Corrosion
6. Tracking
7. Burn Down
8. Wire Down Detection
9. Radio Frequency

# Incorporating Lessons Learned

## 1. **Aeolian Vibration Limits**

- Sag and Tensions for the covered conductor will take into account the terrain. There will be two separate tables for light and heavy loading. The loading limits account for wind and ice.

## 2. **Abrasion**

- SCE's Covered Conductor design uses a Crosslinked High Density Polyethylene layer to help resist abrasion. Additionally, covered conductor must be handled with care in order to prevent damage to the covering.

## 3. **Electrical Withstand**

- SCE uses a triple sheathed covered conductor design, which has been found to be the best choice for long term electrical withstand for trees and with adjacent phases. BIL of SCE's CC is 200 kV.

## 4. **Lightning Protection**

- Surge arresters will be installed at all overhead equipment locations and at UG Dips.

# Incorporating Lessons Learned

## 5. **Corrosion**

- SCE will be using copper covered conductors in coastal applications.

## 6. **Tracking**

- SCE's covered conductor design will include a track resistant XLPE outer layer. Additionally, SCE will mitigate tracking by using polymeric insulators, using crimped connectors, and using a low carbon content sheath.

## 7. **Burn Down of CC**

- SCE will incorporate the following to prevent burn downs.
  - Suitable lightning protection (installation of surge arresters)
  - Reducing electrical stresses and carbon content on sheath material (polymeric insulator, low carbon XLPE, etc.)
  - Correct installation and tensioning (Sag and Tension will take into account terrain such as wind loading and ice)
  - Tree Trimming (SCE will maintain tree trimming requirements)

## 8. **Detection of Downed CC**

- SCE will use SEF method of protection for covered conductors, which is the same protection scheme for bare wire.

## 9. **Radio Frequency Concerns**

- SCE will use low carbon black content sheaths and polymeric insulators to significantly reduced tracking, thus reducing RF problem in coastal area.

# Chapter IV

## Covered Conductor Construction

Energy for What's Ahead<sup>SM</sup>



# 1. Covered Conductor Installation Guideline

This section discusses the covered conductor installation criteria

# Installation Guideline

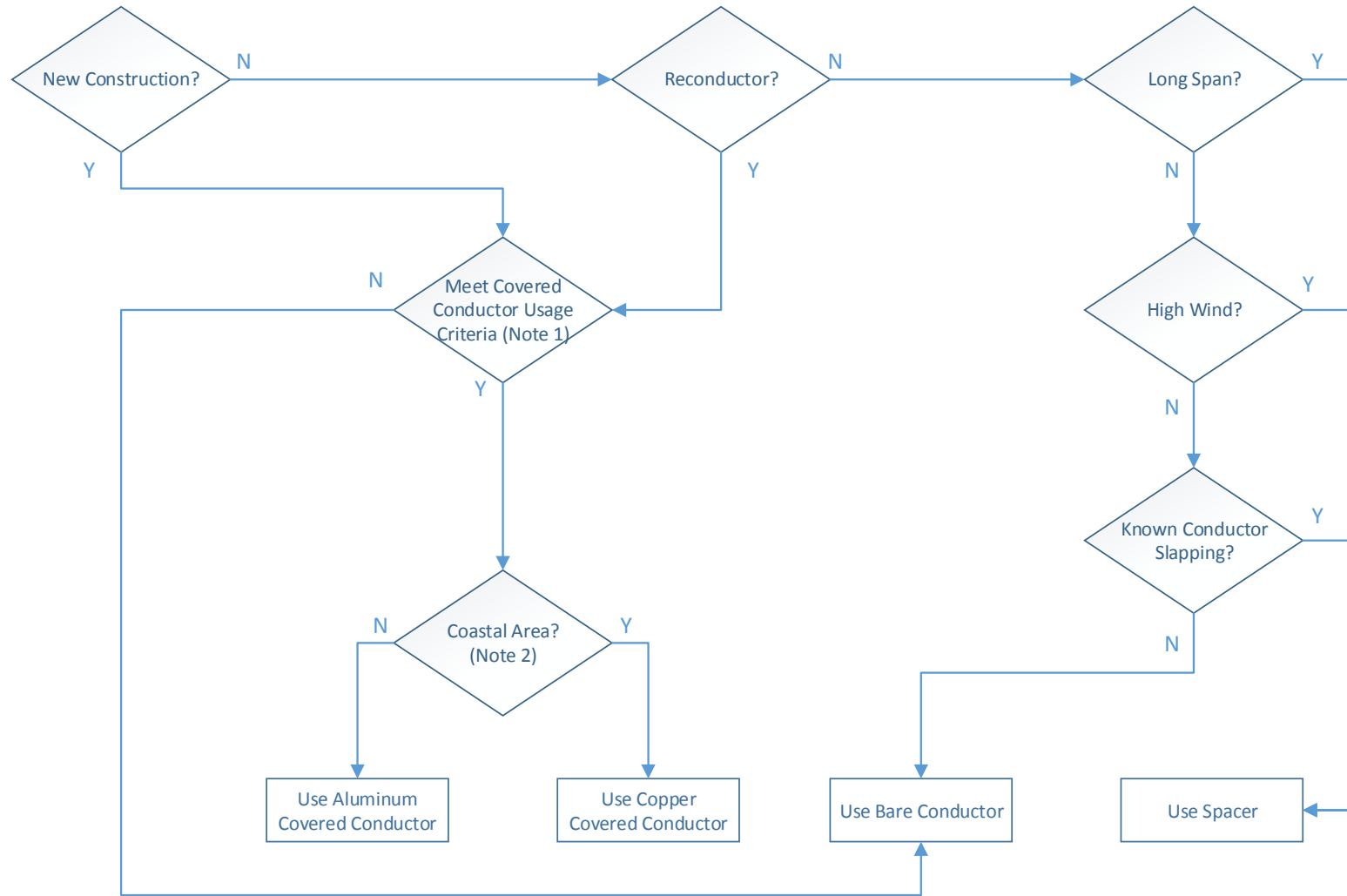

- New Construction and reconstruction in High Fire Areas will require covered conductor
- Reconductor will be triggered by other programs, such as OCP

- Note 1: See Next Slide for Usage Criteria
- Note 2: Coastal Area is defined as area within one mile of the coast



# Covered Conductor Usage Criteria

1. System Operating Bulletin 322 Areas (HFRA)
2. Heavy vegetation with potential tree and palm frond contact
3. Known metallic balloon contact causing circuit outages
4. Any area with outages due to known intermittent contact
5. Coastal areas within one mile of the ocean
6. Any specific area that experiences accelerated corrosion

## 2. Covered Conductor on Three Phases and Neutral

This section discusses the key factors considered to select covering all phases in SCE Standards

# SCE Standards: Covered Conductor on Three Phases and Neutral

- Covered conductor will be used on all three phases in three-wire overhead system (mostly mainline)
- Covered conductor will be used on all two phases in overhead branch lines
- Covered conductor will be used on the neutral wire in four-wire overhead system (20% of SCE system has a neutral wire)

# Analysis Factors

- Phase Spacing is key for the covered conductor
- This analysis will assume a three phase system. Refer to the figure below for phase spacing distances on a composite crossarm.

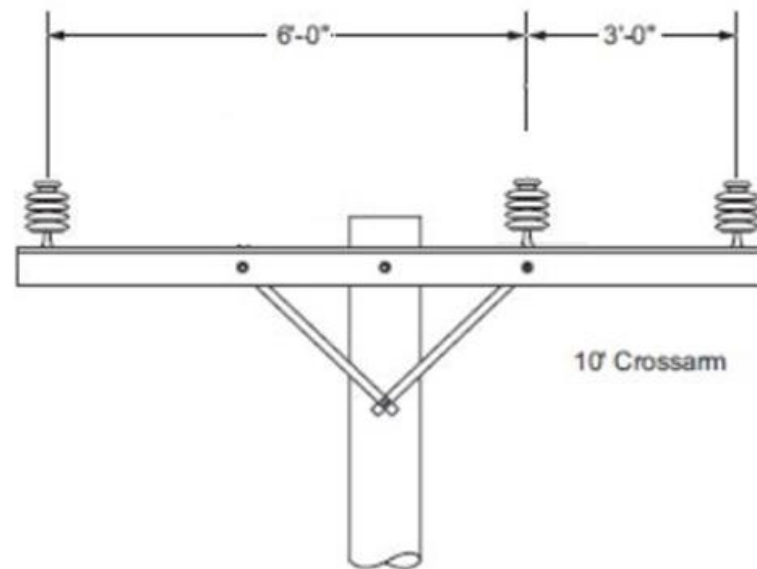

# Evaluation of 1 Phase Covered

- In this configuration, it is assumed that only Phase B will be covered. Phase A and C will be bare wire.
- Analysis of effectiveness for mitigating phase to ground contact
  - This configuration will not be effective in preventing phase to ground contact. Phase A or Phase C will be susceptible to incidental contact with trees, therefore not eliminating the risk of a phase to ground fault.
- Analysis of effectiveness for mitigating phase to phase contact
  - This configuration will not be effective for phase to phase contact. There is 9 inches between the bare Phase A and Phase C. A foreign object or wildlife that is long enough could cause phase to phase contact. Palm fronds can be up to 13 feet long and California Condors have wingspans that are up to 10 ft long, which is enough to cause a phase to phase fault.
- Analysis of fire mitigation effectiveness
  - Covered conductor is considered effective for fire mitigation due to its ability to prevent incidental contact. However, its ability to prevent incidental contact will be compromised if the only one phase is covered.
  - Additionally, downed conductor is still possible due to mechanical failures or other equipment failure. The probability of a bare wire igniting a fire is higher than if it was covered.

## 2 Phase Covered

- In this configuration, it is assumed that Phase A and Phase C will be covered. Phase B will be bare wire.
- Analysis of effectiveness for mitigating phase to ground contact
  - This configuration will not be effective in preventing phase to ground contact. While the probability of a phase to ground contact is lower because Phase A and Phase C will be covered, Phase B will still be susceptible to incidental contact with trees, which will lead to a phase to ground fault.
  - Additionally, some equipment, such as transformers may be within 6 feet from the phases. Phase to ground faults may be possible due to incidental contact between the equipment and the center phase.
- Analysis of effectiveness for mitigating phase to phase contact
  - Because Phase A and Phase C are covered, the probability of phase to phase contact is reduced.
  - Internal SCE studies have shown that current through an object, such as a tree limb, connecting two phases of covered conductor is about 0.2 mA. This value doubles to 0.4 mA if the object is connecting a bare wire and covered conductor.
  - Insulation degradation on the covered conductor will happen at a faster rate, leading to failure happening at a faster rate.
- Analysis of fire mitigation effectiveness
  - The fire mitigation effectiveness is still less than if the system was fully covered. Phase to ground incidental contact is still possible even with two phases covered, leading to arcing that could cause ignition.
  - Furthermore, downed conductor is still possible due to mechanical failure or other equipment failure. The probability of a bare wire igniting a fire is higher than if it was covered.

# Evaluation of 3 Phases Covered

- In this configuration, it is assumed that Phase A, Phase B, and Phase C will be covered.
- Analysis of effectiveness for mitigating phase to ground contact
  - Because the system is fully covered, there is a very low probability of incidental contact causing phase to ground faults.
- Analysis of effectiveness for mitigating phase to phase contact
  - Because the system is fully covered, there is a very low likelihood of incidental contact causing phase to phase faults.
- Analysis of fire mitigation effectiveness
  - Covered conductor is considered effective for fire mitigation due to its ability to prevent incidental contact. By fully covering all three phases, the possibility of faults due to incidental contact is greatly reduced.
  - If a downed wire scenario were to happen, covered conductors are less likely to cause a spark than bare wire. Therefore, the chance of ignition has been greatly reduced.

# Neutral Covered

- In this configuration, it is assumed that Phase A, Phase B, Phase C and the Neutral will be covered.
- Analysis of effectiveness for mitigating phase to neutral contact
  - Because the system is fully covered, there is a very minute likelihood of incidental contact causing phase to phase faults.
- Analysis of fire mitigation effectiveness
  - In a downed wire scenario, a covered neutral will be less likely to cause a spark than a bare neutral.
  - Chance of ignition is reduced



# Other Factors to consider

- Sagging
  - Covered conductor and bare wire are sagged at different tensions
  - If covered conductors were to be sagged like bare wire, it may cause vibration problems
  - Covered conductors have more sag than bare
  - Mixing bare and covered conductor in one crossarm will cause uneven sags
  - Uneven sags may increase the risk of conductor slapping, leading to an increased chance of insulation degradation, arcing, and ignition.
- Benchmark
  - Other utilities use a 3 phase covered system

# Conclusion

- Partially covering the system (1 phase covered, 2 phase covered, bare neutral) will dilute the effectiveness of covered conductor.
- Using covered conductor for all three phases and the neutral promotes SCE's grid resiliency and the elimination of an ignition source.

### 3. SCE Covered Conductor Construction

This section illustrates how Covered Conductor and Wildlife Covers being used in SCE Standards to achieve maximum protection from incidental contacts

# SCE Construction Diagrams

- SCE's covered conductor systems will be all covered
- This includes wildlife covers on dead-ends, terminations, and equipment bushings, jumper wires
- Also illustrated are other Wildfire resilient equipment/hardware, such as composite pole, composite cross-arm, polymer insulator for covered conductor
- These illustrations depict the four common pole configurations:
  - Tangent pole: means covered conductor pass thru insulators
  - Dead-end pole: covered conductor will stripped off to connect to dead-end insulator
  - Transformer pole: stripping cover required for connecting to transformer (or equipment)
  - Riser pole: stripping cover required to connecting to underground cable

# Tangent 4 Wire Construction

Tangent pole does not need other covering hardware

3 Phase, 4 Wire Tangent (Straight-Line) Construction

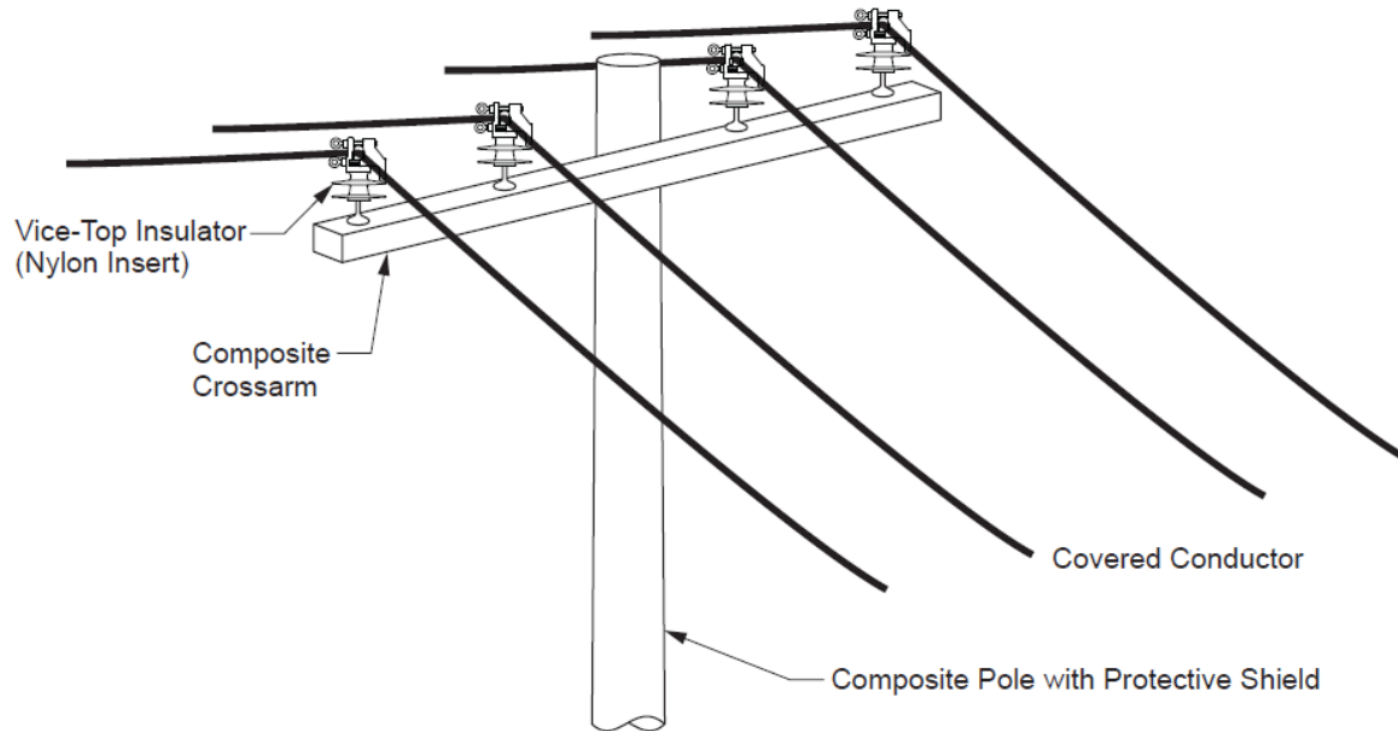

**Same concept for three-wire and two-wire constructions**

# Three-wire Dead-end Construction

Introduce new standards for dead-end cover, composite pole and cross-arm

Single Dead-End (3 Phase, 3 Wire) Construction

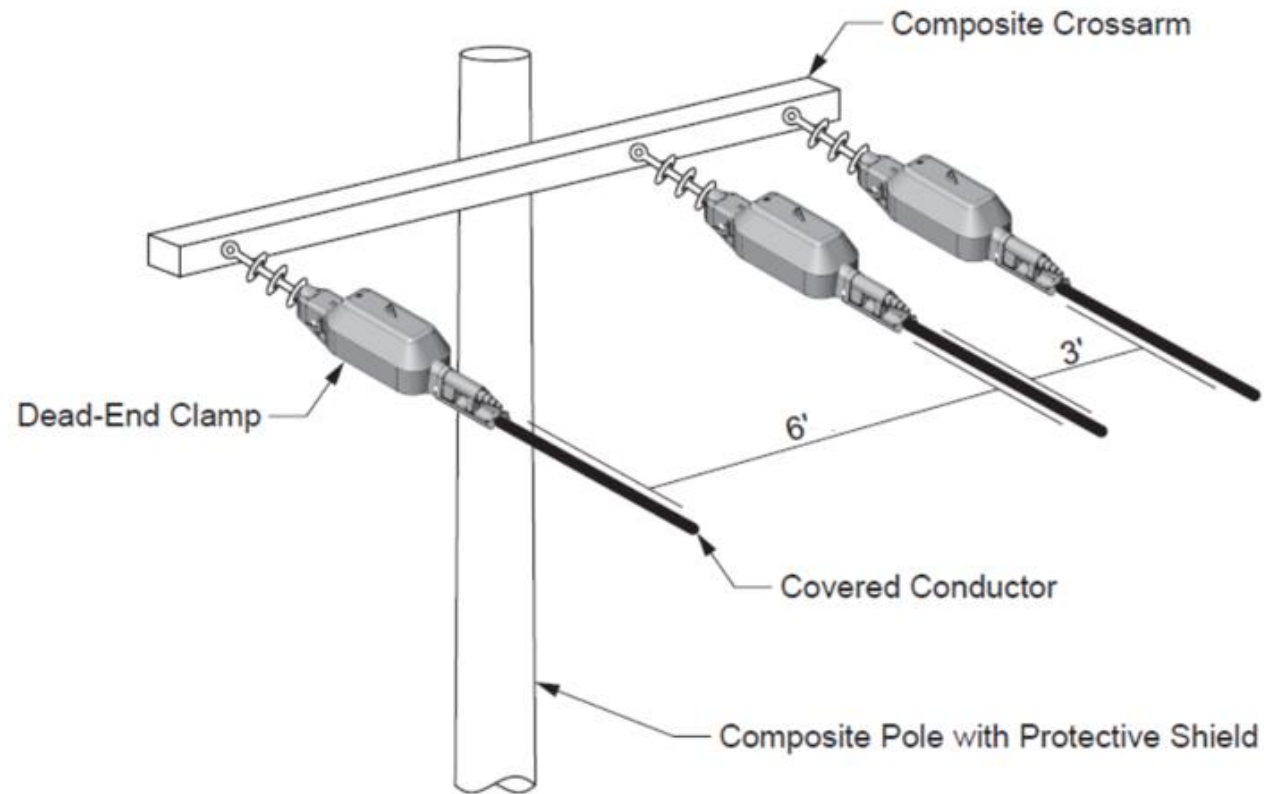

**Same concept for four-wire and two-wire constructions**

# Tangent 2 Wire with Transformer Construction

Overhead Transformer with 2 Phase, 2 Wire Tangent (Straight Line) Construction and Associated Protection (Fuses, Lighting Arresters, Wildlife Guards)

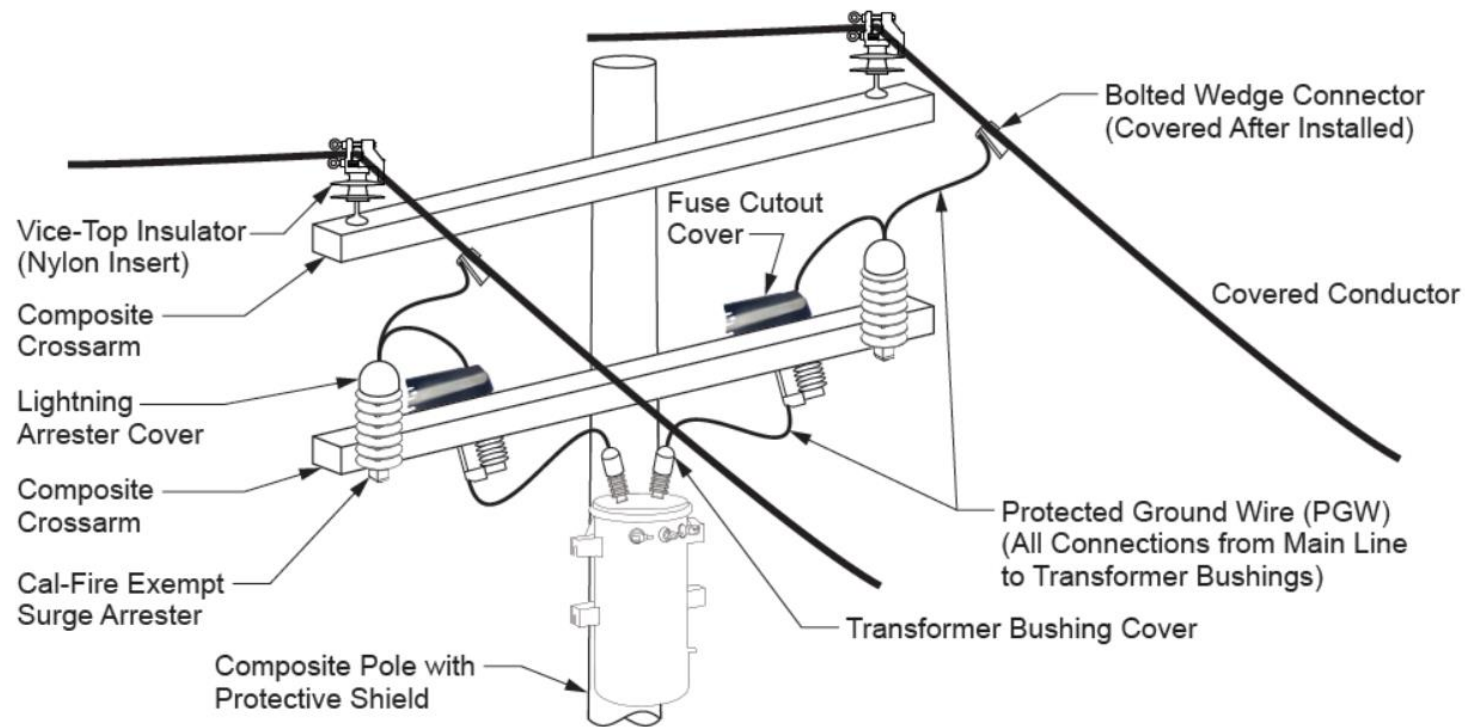

**Same concept for connecting to other equipment: capacitor, switch, remote automatic recloser, etc.**

# Riser Pole Construction

Typical Construction for Underground Dip  
(Riser) Pole with Associated Protection  
(Fuses, Lightning Arrester and Wildlife Protection)

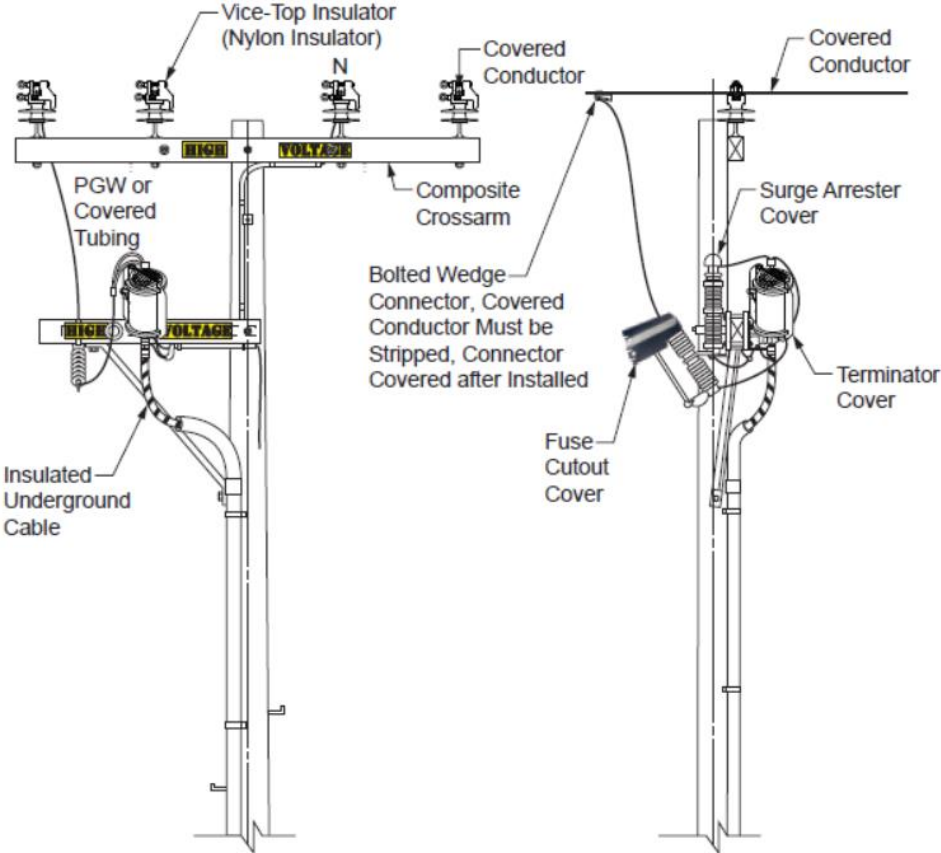

Same concept for three-wire and two-wire constructions



# Splices

- Splices will be covered
- Splices for adjacent conductors shall not be installed next to each other and should be staggered 18 inches end to end.

